

The

Barnard College  
Columbia University  
The Elstree Library

MAR 17 1952

# BARNARD

Alumnae Monthly

HEALTH  
AND  
SPORTS



March  
1952





116th Street

*and*



Heartbreak Ridge

Time was, when something happened at 116th Street and Broadway, you were mighty interested. And it made big news in the Barnard Bulletin.

But your horizons have broadened. Your world is now *the* world and no matter how far from 116th Street something happens, it can be mighty important to you.

Wherever big news happens, The New York Times is there to report it for you. The Times has correspondents in Korea, in Iran, in Germany—even in Moscow, where it is the only American newspaper, with the exception of the communist Daily Worker, to maintain a correspondent.

That means you get a lot of news in The Times. In fact, you get more news in The Times than anywhere else, reported by the largest staff of correspondents of any publication. That's why women in New York and throughout the U.S.—alert, intelligent women—keep informed with The New York Times every single day of the week.



**The New York Times**

"ALL THE NEWS THAT'S FIT TO PRINT"

*Don't think 116th Street is being ignored in the welter of world affairs. The Times has its own student correspondent right on the Barnard campus—and another at Columbia—to keep you in touch with Morningside.*





# THE BARNARD ALUMNAE MONTHLY

Published seven times during the college year, October-November, December-January, February, March, April, May, June, by the Associate Alumnae of Barnard College, 3009 Broadway, New York 27, N. Y.

Volume XLI

March 1952

Number 4

## People in This Issue:

Cover girl **Anne K. Ross '45**, four-time winner of the women's national diving championship, has just arrived in Capetown, South Africa where she will teach physical education at Stellenbosch University for the next two years. (See page 4)



**Dr. Patricia A. Langwell '43**, Mrs. Louis T. Milic in private life, served three years in the Waves, received her Ph.D. in meteorology from New York University and is a member of their teaching staff, currently on leave and expecting her first child in April. (See page 18)

**June Rossbach Bingham '40**, wife of Jonathan Bingham, deputy-administrator of the State Department's Point Four Program, is mother of Sherrell 10, June Mitchell 9, Timothy 7, and Claudia 5. Figaro, the family poodle, is almost one. And the Bingham find time for duets on the violin, viola, cello and piano. (See page 6)

**Caroline A. Chandler, M.D. '29**, is assistant professor of preventive medicine at the Johns Hopkins University School of Medicine, author of **Famous Men of Medicine** and currently the proud owner of a home in Long Green Valley where her chief concern is fall and spring planting, "shrubs, trees, bulbs, seeds, and all manner of sprays and fertilizers." (See page 16)

**Elizabeth Haithwaite '43**, is the only woman instructor teaching physics and black and white and color photography to the employees of the Eastman Kodak Company in Rochester, New York. She left her home in Yonkers to get away from a "big city" atmosphere and plans to spend the rest of her life in a "small town" community. (See page 8)

**Muriel Chevious, M.D. '46**, is a brand new doctor having received her degree from the College of Physicians and Surgeons, Columbia University June 7th, 1951. She is interning at Strong Memorial Hospital in Rochester. (See page 17)

### Picture Credits

*Manny Warman*—fencing class  
*Les Nichols*—forum  
*Bea Laskowitz '50*—sketches  
*Mademoiselle*—Geri Trotta

## CONTENTS

<b>Modern Living</b> . . . . .	2
<i>Iola Stetson Haverstick '46</i>	
<b>Competitive Sports?</b> . . . . .	4
<i>Anne Ross '45</i>	
<b>Bearding the Lion</b> . . . . .	6
<i>June Rossbach Bingham '40</i>	
<b>Photography is Fun</b> . . . . .	8
<i>Elizabeth Haithwaite '43</i>	
<b>Safety on the Job</b> . . . . .	10
<i>Christine Einert '24</i>	
<b>Mysteries Without Mayhem</b> . . . . .	11
<i>Geri Trotta '35</i>	
<b>Progressive Education: Fourth Annual Forum</b>	12
<b>News in Review</b> . . . . .	14
<b>International Health Plan</b> . . . . .	15
<i>Helen Shire Ascher '21</i>	
<b>Safeguards for Child's Health</b> . . . . .	16
<i>Caroline A. Chandler '29</i>	
<b>Intern's Case History</b> . . . . .	17
<i>Muriel Chevious '46</i>	
<b>The Folklore of Weather</b> . . . . .	18
<i>Patricia Langwell '43</i>	
<b>From the Editor's Notebook</b> . . . . .	19
<b>Clubs Coast to Coast</b> . . . . .	20
<b>Class News: 1901-1951</b> . . . . .	21
<b>Candidates for Alumnae Board</b> . . . . .	<i>inside back cover</i>
<b>Coming Events</b> . . . . .	<i>outside back cover</i>

### Editor-in-Chief

FRANCINE SCILEPPI PETRUZZI '46  
 5635 Netherland Avenue  
 Riverdale 71, New York

Advertising Manager: MARY TALIAFERRO WEBB '23

### Editorial Board

Nona Balakian '42	Beulah Amidon Ratliff '15
Diana Hirsh '36	Elizabeth Pratt Rice '38
Myra Koh '50	Amy L. Schaeffer '37
Beatrice Laskowitz '50	Clementine Walker Wheeler '36
Inez Nelbach '47	Marian Churchill White '29

### Ex-officio

Marjorie Turner Callahan '26      Mary Roohan Reilly '37

### Publications Committee

Helen Le Page Chamberlain '24, *Chairman*  
 Helen Erskine '04      Dorothy Woolf '28  
 Iola Stetson Haverstick '46





Cook, Chemist or Both?

# Modern Living

by *Iola Stetson Haverstick '46*

SHOULD Barnard stick to aloof subjects like the Odes of Horace, the campaigns of Napoleon, the loves of Shelley and the sins of Byron, the cabinets of Andrew Jackson and leave personal matters like child-parent relations or preparation for marriage to the clinics?

Barnard has an answer. "We have only to look around us," says Dean Millicent C. McIntosh, "to see the changes brought on by two world wars, by the increased facility of communication and transportation, by the easing of the divorce laws, by the flight from orthodox religious beliefs. These changes bring new problems and new pressures especially to young people who no longer find established moral codes to cling to."

## Emotional Problems

"If we believe," she says, "that the liberal arts college should help students apply their education to life situations, then we must first help the student find a more concrete and relevant approach to her own problems."

"We know today that many of these problems have an emotional basis and stem from the environment of the child."

"Many are quite normal and stem only from the adjustments required

of a girl making her first entrance into a more adult world. To cope with these varied problems, we have set up a counseling program which ranges from a staff psychiatrist to class advisors picked from the faculty and to a specially constructed course in modern living."

## First Staff Psychiatrist

Barnard's first staff psychiatrist is one of her own alumnae, Dr. A. Louise Brush '25. A small, thin woman with a basic way of looking at things, Dr. Brush has been connected with the college on a part time basis since 1946. She also practices privately and at the New York and Presbyterian Hospitals. Her offices are open to Barnard students for an average of 7 to 8 hours a week and she sees about sixty girls a year. The problems she treats range from difficulties with studies to conflicts with parents. Like the medical treatment, the psychiatric treatment provided

by the College is of a preventive or stop gap nature.

Students who wish to see Dr. Brush are channeled through another alumna, Dr. Marjory Nelson '28, Barnard's staff physician.

Dr. Nelson, who has two children of her own, is a bustling efficient woman with a firm belief that something can be done for the emotional as well as the physical needs of students. "If a girl gets a chance to air her problems to someone with an objective point of view," she says, "she is less apt to have chronic indigestion or colds."

## Rorschach Test

If the staff psychiatrist were the only way in which personal counseling has penetrated into Barnard, only 10% of the girls would be aware of it. But there are other more far-reaching ways. When freshmen and transfers first come to Barnard, they take—if they want to: and most of them do—a group Rorschach test. The College uses the Rorschach primarily as a personality test. It is one way of finding out whether a girl is particularly gifted or creative.

Because the Rorschach test has been given to so many thousands of people, psychiatrists are able to detect certain patterns of reaction and,





in some cases, actually label a mental illness. At Barnard, Dean McIntosh points out, the results are used as a sort of straw in the wind to enable class advisors and the medical staff to keep a special eye on the girls most likely to have emotional problems.

Every girl in college faces certain emotional adjustments and problems. Some of these may evolve around relations with boys. Others may concern vocational decisions. There are also cultural and environmental conflicts. A girl brought up in a strict religious tradition may be shocked by her contemporary who believes in neither heaven nor hell. Another girl brought up in a family where the word "sex" is considered obscene can't help but be confused at her first female "bull session" in the dormitory. A Chinese student, to whom a kiss is a very intimate thing, may be unsettled at the pass from the boy she has just met.

In recent years, the College has taken cognizance of these problems by setting up a required course for freshmen and transfers called Modern Living. The object of Modern Living is not to provide a Dorothy Dix question-and-answer bureau, but to discuss and present certain principles of behavior to the girls from psychological, sociological, and historical points of view.

### ABC's of Personal Hygiene

Modern Living is a one semester course divided into four parts. The first part is given by Dr. Nelson who lectures on the fundamental A B C's of personal hygiene, sex, reproduction, child development, and community health problems. She is followed by Associate Professor Mirra Komarovsky '26 of the Sociology department. Dr. Komarovsky deals with dating and courtship—particularly the emotional conflicts which arise from differences in these customs.

The final lectures are given by Dean McIntosh who tries to give the girls an insight into problems involved in the family group such as the position of the child in the family, the economic circumstances of the parents, the temperament of the parents and their relation to each other.

"I try to stress particularly that it is necessary for a girl to approach her parents with understanding

rather than rebelling in hostile ways," says Dean McIntosh.

While heartily endorsing the girl who wishes to combine marriage and a career, the Dean does not believe that all girls have to be research chemists or teach French while producing children. "The main thing," she says, "is that a girl does not become a vegetable. She should retain her intellectual interests while making a pie or vacuuming a rug as well as while dictating a letter or writing fashion copy."

This year a new feature was added to Modern Living. It was a series of small discussion groups which met weekly under the direction of a moderator. The girls themselves had asked for it, and a gift of money from the Grant Foundation made it possible. Moderator was Mrs. Tilla



Van Everen, a serious young sociologist, who also teaches at Brooklyn and Hunter colleges. She conducted her discussion groups at Barnard along topics the students themselves suggested — dating, relations with parents, vocations, and marriage. For the male point of view, Mrs. Van Everen imported several Columbia boys from across the street to answer some of the questions raised. The boys were quizzed particularly on whether or not they would allow their wives to have careers. "I'm not forcing any qualifications on my wife," one boy said candidly. "The main point is whether we get along together and find each other interesting."

To get the student reaction to Modern Living, an evaluation sheet was passed out to each girl at the end of the semester. These sheets, which were not to be signed, asked the students to grade each part of the course according to what they thought of the material and the teacher. This year, a good 50% of the girls wrote all over the back of

the sheets and their comments on the course ranged from ". . . simply confirms what I already knew and therefore a dead loss . . ." to ". . . the most wonderful and helpful lectures I have ever heard. . . ."

One girl felt she "was left up in the air" and wanted "more individual help in the discussion groups." "Most of us," wrote another, "think of marriage and motherhood as a bridge we will cross when we come to it. Modern Living reveals the importance of preparing for the future now." "Should be a full year course," said some. "There should be tests," said others, "to determine whether or not all of us need the course."

In general, the students felt that they were given, at the beginning of the course, too much detailed physiology. "A repetition of high school biology" was the typical reaction. To balance this, they want more general psychology and sociology on the family and the development of the individual. The discussion groups won their almost complete approval, but they felt that the sections, now made up of twenty-eight girls, should be even smaller to allow time for everyone to talk and ask questions.

### Aims at Middle Group

The College is trying each year to improve its Modern Living course according to the needs of the girls. "I don't worry," says Dean McIntosh, "about reaching the independent girls who have already worked out an adjustment for themselves. Nor, in Modern Living, can we do much about the girls who have genuine mental and emotional conflicts. We try to give these the individual help they need through Dr. Nelson and Dr. Brush. The girls we are trying to reach are the large middle group who need some frame of reference for their problems and some general standards to apply towards their solutions."

Accordingly, the future problem for Barnard, the Dean believes, is not whether a program of planning for Modern Living has its place in the College. Nor is it a question of substituting such a course for the Odes of Horace. "Our problem," she says, "is to find, within the liberal arts tradition of preparing students for life, a happy medium between too much help for the student and not enough help."





A class in the fine art of fencing at Barnard

# COMPETITIVE SPORTS?

by Anne Ross '45

WITH a two year stint of teaching physical education at Stellenbosch University in South Africa immediately ahead, I'm beginning to wonder about the questions which the Afrikaners will ask about the United States. Since my job will be in a coeducational university, I expect many "bull sessions" about American sports. "How are the Dodgers doing?" "What are the differences between football and rugby?" "What about college sports scandals in the United States?" "Do college boys really get paid for playing basketball?" "What is the sanity code, and does it really control college sports conduct?" They are the leading questions I expect.

According to news space and public concern here, the status of men's intercollegiate athletics is of greatest breadth and interest to us. Certainly it is a subject which is under fire at the moment. It seems to me that the precarious situation in college sports is not so much an indication of decadence or delinquency, as some purists would have it, but one of over-emphasis.

The snowballing of extra curricular sports has been

increasing steadily for some time. Under the guise of character building and the glory of alma mater, boys in secondary schools are scouted, auditioned, then given various incentives to enroll in some sports-minded university or college via the questionable "athletic" scholarship. In the succeeding process of gaining mechanical efficiency, these chosen ones must go through many hours of physical drill, minute study of plays, the pressures of big games, and often arduous travel — all in addition to maintaining at least passing college grades "by hook or crook."

Some come through successfully in all respects, and emerge prepared for a career and the normal problems of living. But there are those who suffer from the sapping of intellectual initiative which this kind of program can bring. They may be mentally or physically incapable of its demands, and have cause to regret the glory and concomitants of the B.M.O.C. (Big Man on Campus.) There are often lasting injuries to remind them of the "Great College Years." Most unfortunate are those teachers and students who lose their sense of



proportion and consider college athletics the greatest phase of college life.

Traditionally Americans are great sportsmen, and this tradition has good foundation. From the point of view of a former competitor, not in intercollegiate sports but in intensive A.A.U. competition, I definitely believe in the values of highly skilled sports. The process of single-minded concentration toward a goal; the accompanying relationships between teacher and student, among teammates and rivals; the great satisfactions of accomplishment—all these things are tremendously broadening and contribute to the full development of the individual.

### Can Athletic Scholarships be Justified?

But in relation to institutions of learning, how can educators condone the neglect and abuse of scholarship for the sake of the Team? How can athletic scholarships be justified? Can we defend, with a clear conscience, the proportion of time spent in many schools on the unbelievably consuming activities of varsity teams? A student cannot be expected to recognize the relative values of the college program as a whole if the administration does not.

As a member of the physical education profession, I feel that all of us should stand for those principles which will be the best for the students under our care. The values of physical education in education as a whole have long been established; so why jeopardize these by unreasonable over-emphasis? We owe what talents and time we have equally to all tuition-paying students, and have no right to devote ourselves exclusively to a few highly skilled players. Nor is it fair to so heavily tax these players that they have neither time nor inclination nor physical energy for their academic work—their foremost purpose and obligation in college.

As an American abroad it will be quite an assignment

to explain the complicated picture of sports in education today. In many cases administrators claim ignorance of practices going on in their own institutions. Coaches are wide-eyed and protesting, or belligerent and defensive. Players cling to fierce and often misplaced loyalties. Sports writers ridicule the efforts of those who try to de-emphasize college athletics, or else feebly agree that something ought to be done about it. Professors close their eyes; alumni wave the school colors and cheer blindly.

The college athletic program has been studied recently by an imposing committee of college presidents and coaches. A new code of practices has been recommended. Thirty-six colleges over the country have dropped football—certainly no solution to the problem, but at least an indication of awareness of trouble and one attempt to reach its core.

### Smaller and Saner Athletic Program

Sports can give great satisfaction. There are wide concomitant benefits and lessons learned. But isn't it a matter of relative values? If one's greatest ambition in life is to be a great basketball player, that's wonderful! Play basketball. But don't confuse the sport or its performance with the primary purposes of higher education. Degrees are not given for extra touchdowns or national championship basketball.

This is a small protest from one who believes that college education is concerned first with the training and development of the mind, the forming of mature judgments backed up by knowledge and information. I hope that in the next year the intercollegiate athletic program will be maintained on a smaller, saner scale, and that I can proudly point out to my South African colleagues the intelligent reforms made by the United States in college sports.

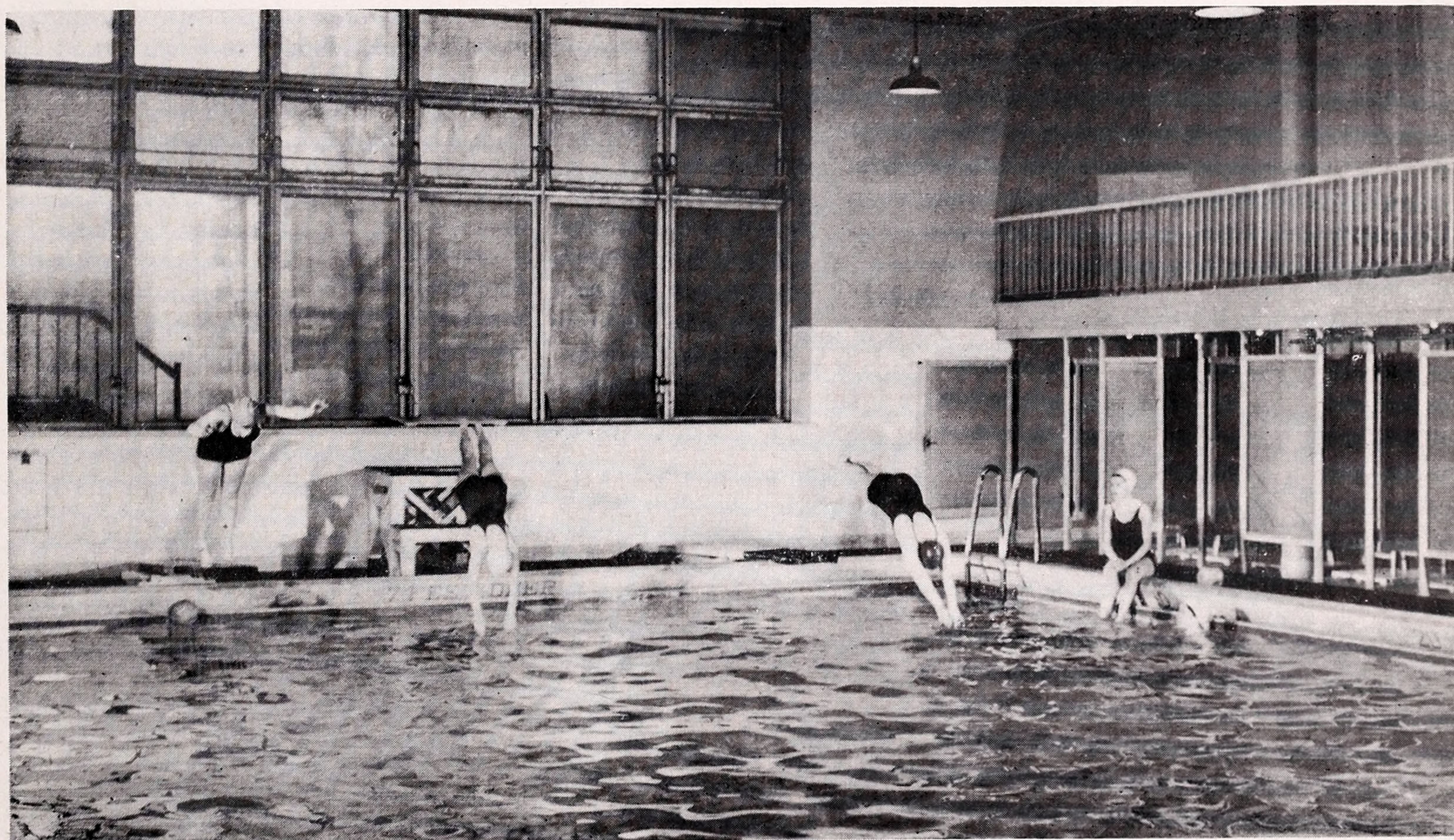

A swimming race in the Barnard pool



# Bearding the Lion



by June Rossbach Bingham '40

**N**OW it's the psychiatrists who want to know what *we* think of *them*.

In May 1950, for the first time in its 106 years of existence, the American Psychiatric Association scheduled at its annual convention a round table discussion on "What the Public Thinks of Psychiatry." This writer was one of the laymen invited to take part, and, with trepidation, left a most unpsychiatric home and husband and children to go beard the lion in his own den.

## Only One Beard in View

The Detroit hotels which housed the convention were teeming with psychiatrists. Much to the surprise of this layman, who had expected the doctors to sport long beards, thick glasses and a pasty indoor look, most of them were young (in their thirties and forties), clean-shaven and looked as if they shot a mean game of golf. Only one beard was in evidence, and the few mustaches there were veered toward the crisp toothbrush rather than the soup-strainer variety.

Nor was this the only surprise. The great interest shown in our dinner discussion was another. Over 300 psychiatrists and their wives crowded the room, some having to stand. It was as if the spirit of Robert Burns had suddenly whis-

pered to the mid-twentieth century psychiatrists the sage lines:

Oh wad some power the giftie  
gie us

To see oursels as others see us.

No words were minced by any of the speakers. They were informed that to the layman they appear as everything from maniacs to walking lie-detectors, all the way from devils to gods. This picture in the laymind was credited partly to the many movies, novels, plays, comics, detective stories and radio shows in which at least one character (usually the villain) is a psychiatrist, and partly to the pre-existing fears and hopes in the hearts of laymen, who are, on the one hand fascinated by the new insights of psychiatry, and on the other hand fearful that these same insights will teach them something unpleasant about themselves.

## Only 6,000 Psychiatrists in U.S.

Most people, it was stated, have nothing but their imagination to go on in picturing psychiatrists because they have never seen a real live one, face to face. With only 6,000 psychiatrists in our country of 151 million people, and with most psychiatrists sticking close to office, hospital or laboratory, we laymen have no opportunity to really know them.

Why should they care so much? Could it be that they suffer from a

peculiar kind of loneliness, up in their ivory tower? Is there a feeling of being cut off from the people—the grass roots—the every-day people? Certainly it is not impossible that psychiatrists who spend their days with uncommon people (their patients), and their evenings with other psychiatrists (who have spent *their* days with uncommon people), should feel lonely and cut off from their normal, every-day fellow beings.

## "What Am I Thinking?"

As to our false picture of them, it was this particular layman's impression that the doctors were quite hurt by what we had to tell them:

Against our charge that they were maniacs (so many Grade B and C movies picture them as such), a psychiatrist answered that just because a doctor might have emotional problems of his own this need not prevent him from being of help to his patients. After all, he said poignantly, there's no reason why the psychiatric profession should be the *only* one to have no unbalanced members.

Against our charge that they were walking lie-detectors, a psychiatrist complained that whenever he is introduced to a layman, the person says, "Oh, so you're a psychiatrist. Tell me! What am I thinking?"



The doctor sighed. "They seem to think we are mind-readers. We're not! We don't know that much."

Against our charge that they were devils, a doctor went so far as to confess that on his shingle and notepaper he doesn't use the word psychiatrist. "I say my practice is limited to Nervous Diseases. Otherwise I might not have a practice." This doctor was then hopped on by his colleagues, who accused him of giving in to the public's prejudice rather than combatting it.

### Debunked in Cartoons

Against our charge that they were gods, one of the professional members of the panel, Dr. Fritz Redlich, chief psychiatrist of the Yale University Medical School, told of research he is doing on the frequency with which psychiatrists are made fun of in cartoons and caricatures. Said he: "One purpose of the caricature is to debunk. There is no need to debunk a person unless he has already been raised to some kind of a pedestal." Psychiatrists, he went on to say, have appeared over the last twenty years steadily in more and more cartoons, whereas ministers, who used to appear often, now appear far less frequently. The need to debunk the psychiatrist seems to have replaced the need to debunk the minister.

This research of his subsequently led to a meeting with your reporter in New Haven, which in turn led to the decision to collaborate on a book for the general public, using humor to explain psychiatry. The cover of this book, which will be published by Alfred A. Knopf in September, will probably include a cartoon of a little round man, naked except for spats and shoes, standing on the street say-

ing to a policeman: "See a good psychiatrist! For what?" The title to be: *Stripped To Essentials: Psychiatry and Everyday Life*.

If we want to meet the psychiatrists half-way, there is certainly one important thing we might do. That is to become aware that we sometimes unconsciously resist their ideas. Why we unconsciously balk at these modern concepts is not as immediately important as realizing *that we do so balk*.

All of us, if we stop to think, can find words which, if spoken in our presence, make our hackles rise. An adolescent girl will feel dizzy if she hears the word "breast"; a young matron with children will leave the room if the word "pregnancy" is pronounced: these are actual cases of quite normal people. All of us have some bruised painful inner areas which we unconsciously protect by throwing up a screen of huffiness or embarrassment or anger when anything approaches too close.

### Oedipus Complex in Hamlet

Such unconscious resistance in a layman can be ferocious. This writer once witnessed the casual mentioning to a brilliant, urbane professor of English literature, by a psychiatrist friend, that the character of Hamlet is a classic example of what Freud called the Oedipus Complex. The Professor got red in the face and his usual politeness disappeared. "Absolute nonsense!" he shouted. "I've never seen that mentioned in any of the critiques. It simply isn't true!" The trouble was that he didn't know he was being defensive. He didn't dream that his immediate, instinctive reaction of No, No, was not the product of reason or logic, but of raw emotion. And had

he recognized his own reaction as emotionally-based, he mightn't have been so smugly sure that the theory about Hamlet was a hundred percent wrong and the psychiatrist an utter fool.

This doesn't mean that we laymen should open our minds like the mouths of baby birds and obediently gag down whatever the psychiatrists choose to pop into them. The psychiatrists, precisely because they are human, can be wrong like anyone else. But it does mean that when we are aware we are subject to defensive freezing up, we'll watch ourselves. The symptoms are easy to spot: blood rises to the head—in anger or embarrassment—and our voices come out loud and positive. When we hear ourselves booming "Nonsense!" or "I refuse to believe any such thing!" it may be a sign, "Warning: Unconscious Emotions At Work."

### Resistance to Certain Words

Therefore, if we laymen will go so far as to accept the psychiatrists' picture of *us*, clinically proved to be a true one, as creatures with considerable and quite natural unconscious resistance to certain words and ideas, we will have come half-way. If, when our hair rises at some new psychiatric insight, we think, well, wait a minute, this may not be as bad as it seems at first—and even if it doesn't fit in with what we have believed up to now, that doesn't necessarily mean it's false—we will be opening the door to further light and air and truth between us and them.

Surely there's plenty of crucial work in this world which will never get done until we, the laymen, and they, the psychiatrists, are willing to try and do it together.

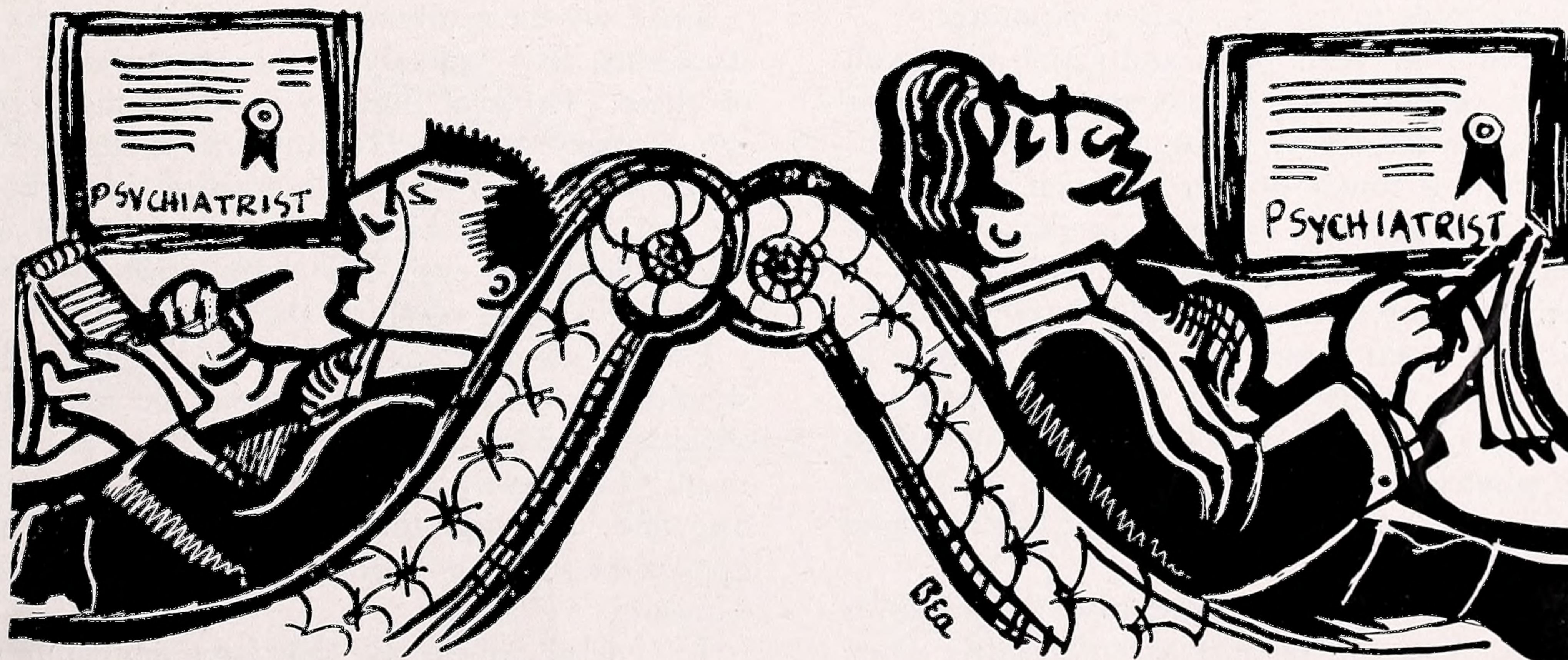





a. **Camera Motion:** Left—incorrect. Right—correct "squeezing" technique.

# Photography is Fun

by ELIZABETH HAITHWAITE '43

PHOTOGRAPHY is fun. It is fun to take pictures to record happy events, and it is fun to view the final pictures and reminisce about them. Yes, photography is fun—if we know the few essentials necessary for getting good pictures.

The word "photography" means "to draw with light." Light, then, is an important tool. Without it we cannot make photographs. Not only must we have light, but we must make certain we have the *right amount* of light for our particular film and camera combination. That means, we have to use the correct exposure.

You will find that with black-and-white films you have a greater range of acceptable exposures whereas with color film the leeway of exposures which will produce good results is much smaller. As you take more and more pictures you will become familiar with the exposure tolerances for your particular equipment.

When taking pictures we are usually happy and excited and in our great desire to "get" the picture at just the right time we use a little too much energy to release the shutter lever. This results in a picture which suffers from what is called "camera motion." It is fuzzy all over and usually you can see double or triple images instead of single ones.

To correct this fault it is not necessary to calm down and be serious. You can be just as enthusiastic when

you press the shutter if you will just brace the palm of your hand so that it will cushion the jab you give the shutter lever (See illustration A). By using this "squeezing" action you can press as hard as you want and still get clear pictures. While you are learning to master this technique, use a shutter speed of 1/50 sec or 1/100 sec if you have a camera with adjustable speeds and apertures. For the box camera owners, a little less energetic action should be used initially until you have become accustomed to the new method.

Since we have already mentioned cameras with adjustments, let's talk about the apertures or f-numbers on them. Think of the way in which the pupil of your eye changes size as the amount of light entering it changes. Camera apertures operate similarly, but they are not automatic as the diaphragm in our eye is. In bright light the eye's iris closes down to prevent too much light from reaching the retina.

Under similar conditions the camera diaphragm should be closed down to prevent too much light from striking the film which would produce an overexposed result. Conversely, in dim illumination the pupil opens up; and, likewise, the camera diaphragm should be opened or set at a smaller f-number to prevent underexposure.

In general, we can say that from one f-number to the





b. **Depth of Field:** Left—wide aperture, short depth. Right—small aperture, great depth of field.

next smaller number on the aperture scale the amount of light striking the film is *doubled*. Use this as a guide when changing shutter speeds to stop action or camera motion. Remember f-numbers and shutter speeds are reciprocals: as you cut the shutter speed in half you can compensate by setting the aperture at the next smaller number.

A common reaction to this is, why not take all pictures with fast shutter speeds to stop action and camera motion and compensate by using a large lens diaphragm opening (small f-number)? This is fine if your judgment of subject distance for setting your camera is accurate. As the lens opening increases, the range of distances that will be sharp with respect to the distance set on the camera distance scale will be smaller.

In other words, with a large opening you have to be more accurate in setting the distance on the camera scale. (See illustration B.) As the lens opening decreases, the range of distances that will be sharp or the "depth of field" increases. From this standpoint it would be desirable to use small lens openings, but then you have to use slow shutter speeds to get enough light on the film. Even in photography "you can't have your cake and eat it too." A range finder or a tape measure will aid you in "focusing" your camera for the proper distance.

Just a word about view finders. They are similar to

"sights" on a gun and just as important. Get to know your camera and its view finder. If you are having difficulty and are cutting off your subject's head, feet, arms, etc., try the following. Take several pictures of subjects *at different distances* carefully diagraming on a piece of paper the exact area you see in the finder. Have the film processed and printed and compare the prints with your diagrams. In this way you can see exactly where your trouble is. Note that as you get closer to your subject careful use of the view finder becomes more important.

For close-ups (subjects closer than about 6 feet) you will have to compensate for what is called parallax. (See illustration C.) Since the finder and the camera lens are about an inch and a half apart they will "see" different things. To allow for this, carefully compose your picture in the finder and then tip the camera slightly *toward the finder*. If the finder is above the lens, tip the camera up—if to one side move the camera to that side. Experience with your camera will be the best guide as to how much you must tip it to make corrections for parallax for various distances.

To take good pictures then, use the proper exposure, hold the camera steady, set distance scale for the correct subject distance, and know how to use your view finder. Try these suggestions, practice them, take loads of pictures and have fun doing it!

c. **Parallax:**

Between 12 and 15 feet, viewfinder and lens "see" same thing. At less than 6 ft. correction must be made, since they don't coincide at this point.

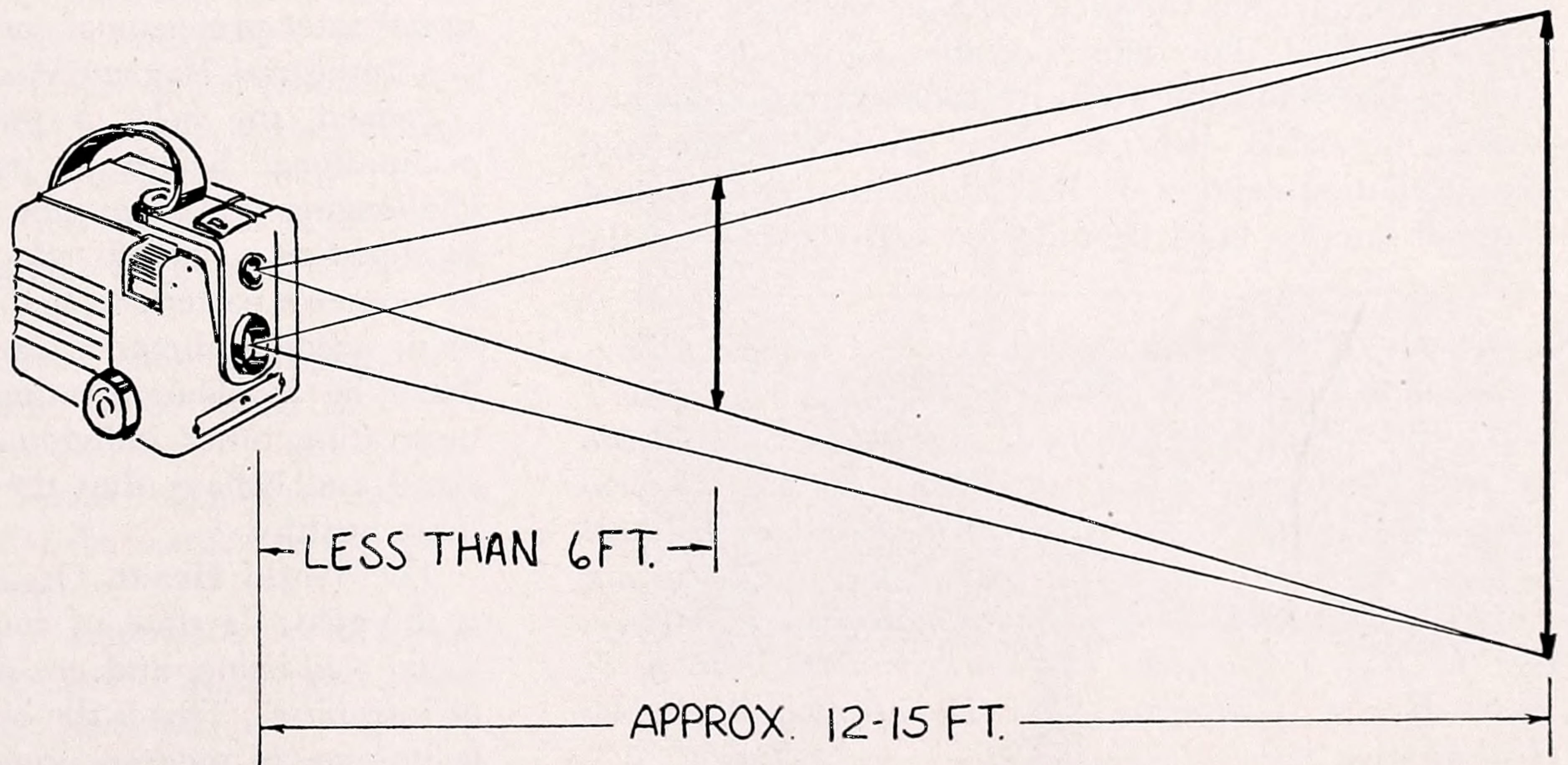



# Safety on the Job

by CHRISTINE EINERT, M.D. '24

THE dominant aspect of public health is prevention, and one of the most modern and comprehensive aspects is its occupational health program.

While some states have relatively new programs, the concept of diseases due to occupation goes back to 1700, when Bernadino Ramazzini published his pioneering text "de Morbus Artificum"—of diseases of workers. He included not only lead poisoning, diseases of miners and such, but also "the painful knees of nuns from much kneeling," and the fact that he "marvelled to see how the clinicians go scot free when there are serious epidemics about, . . ." This he "could not ascribe to any particular precautions on their part, but rather to their taking a good deal of exercise and to their cheerful frame of mind when they go home with their pockets full of fees."

The real newness of occupational health work lies in its professional teamwork and its techniques. Physicians, nurses, engineers, chemists, sanitarians, statisticians, and health educators all have a place in the program. The objective of occupational health is not only to make healthy and safe the places where 50 million Americans spend one-third of their adult lives, but also to steer the workers themselves toward their most healthful way of living longest.

## A-Bomb Plants Safe

Where occupational diseases have been reported or in companies too new or small to have provided for their own protection, the public health industrial hygiene engineers and chemists analyze the hazards of dust, fume or gas, determine the safe limits, and suggest ways of controlling the situation. (Best of all, with some wise companies, these specialists are called in during the planning of new processes to incorporate safe methods into the original design; perhaps the A-Bomb plants are the outstanding example of such advance planning for health and safety.)

The skills needed for such analysis are quite specialized and varied. For some, portable equipment can be used to determine the exposure directly; examples are, carbon monoxide, benzene, noise levels, lighting and some radiation exposures. For other situations, air and material samples must be collected and returned to the

laboratory for elaborate analyses to the exactness of a thousandth of a milligram as, for instance, lead or mercury in air. In other cases, only by physical examination and laboratory tests of individuals can an opinion on safe limits be achieved. Or perhaps the free silica content of a dust needs analysis by x-ray diffraction for complete evaluation, as is the case in some jobs involving fire-brick repair or diatomaceous earth exposures. Often all of the techniques cited are needed for one situation, with the remaining members of the team called in to tabulate, analyze and make clear the meaning of the results to management and worker.

The use of specific chemicals in industry has, of course, skyrocketed in the past twenty years. The use of not only plastics, new solvents, and numerous other organic chemicals, but also the whole field of agricultural chemicals to improve growth and as insecticides, has introduced new health problems.

## Outstanding Women in Field

Famous pioneer in the field of occupational health is Dr. Alice Hamilton, who in 1912 was the only U. S. authority on lead poisoning at the Brussels Congress on Occupational Accidents & Diseases. In 1919, she was the first woman appointed to teach at Harvard University (on condition she refrain from walking in the academic procession!) only because, to quote herself, "I was really about the only candidate available." In two states where industrial hygiene service is part of the Labor Department, there are outstanding women physicians. Dr. May R. Mayers is assistant chief and toxicologist in the Division of Industrial Hygiene and Safety Standards in New York. Dr. Harriet Hardy is consultant to the Division of Occupational Hygiene, Massachusetts Department of Labor and Industries. Anna M. Baetjer, Sc.D. is currently not only professor of physiological hygiene, Johns Hopkins University School of Public Health, but also President of the national inter-professional society in this field, the American Industrial Hygiene Association.

Indeed, the field of public health in general, and occupational health in particular, may be especially challenging to women, not just to doctors, but to nurses, biostatisticians, health educators and others. It is part of woman's pattern to help others to do things. In this field, accomplishments are rarely direct and tangible. They lie in demonstrating need in teaching and in motivating other individuals and groups so to understand and behave that they and those about them remain healthy.

The World Health Organization definition of health is the goal; "a state of complete physical, mental, and social well-being, and not merely the absence of disease or infirmity." This is the objective of the teamwork and techniques of modern occupational health programs.

---

. . . Dr. Einert graduated from the College of Physicians and Surgeons in 1928 and received her master's degree in public health from Harvard in 1950. In the interim, she spent 10 years in private practice in New York City; 3 years in industrial medicine as medical director for 6,000 employees in a heavy industry and 1 year in the "atomic city" of Oak Ridge, Tennessee. For the past 5 years, she has worked in the Bureau of Adult Health, California State Department of Public Health.



# Mysteries Without Mayhem

## AN INTERVIEW WITH GERI TROTTA '35

GERI TROTTA'S first novel *Veronica Died Monday* starts a new series of mystery stories to be published yearly by Dodd Mead and Co. and aimed at the women's market.

"There'll be no accent on guts and gore," says Miss Trotta '35, a slight, dashing, young woman who serves as contributing editor for *Mademoiselle Magazine* covering three departments—restaurants, silver and shopping.

Instead of a surplus of bodies, the author offers rounded characters and exotic backgrounds. *Veronica Died Monday* takes place in an intriguing brownstone house in New York's Sutton Place area.

Geri, herself, lives in one of the oldest farmhouses left in the Murray Hill section of New York. It boasts a two-story carriage house out back where her husband, ace photographer Mark Shaw, has his studio.

The house is currently in the middle of a major repair job with walls being broken down and a kitchen-dining area moved to the second floor so that Geri can begin experimenting with the fabulous recipes she gathers in her daily chores.

On the mantle of the farmhouse at 142 East 30th St. is Geri's collection's of white Parian hands. Her other fancy is Georgian paste jewelry. She haunts the Jewelers' Exchange on the Bowery and after some sharp bargaining comes home with valuable baubles.

### "No English Courses Whatsoever"

This dream-like existence started promptly for Miss Trotta upon graduation from Barnard as a fine arts major "with no English courses whatsoever." She won the first *Harper's Bazaar* college board contest and started working with them at \$15 a week with a definite promise that she could start writing very soon.

Six months later she began writing copy. A few years later, she switched to *Mademoiselle* as their first full-time copy editor.

"I worked until 2:00 A.M. in those days but that's something you do once when you're young and then never again," she says.

For eight years she wrote about "suits every fall and shorts every May" and decided she wanted to free-lance and get away from fashion copy.

As contributing editor, she is responsible for three departments and then does extra stories as she goes along.

Occasionally, she and her husband, who won the Art Directors' Gold Medal last year, work together on

a story. When they visited Mexico last year, they interviewed Tamayo, the artist, for *Art News* and Mark took the pictures.

In general though their work follows different paths.

Geri doesn't specialize in subject matter for her articles but if she ever did the medical field would win out. Her 10 page article on plastic surgery for *Look Magazine* was the longest signed piece they ever ran by a free-lance writer.

Home-life for the Shaws revolves around their work. Although, at one point they shared their hearth with 9 cats, 7 permanent ones and 2 visitors.

They both love to travel and plan a flying trip to Jamaica this Spring. April is their favorite vacation month.

The *Veronica* series will emphasize locale. Mexico is next on the list and then Paris. *Veronica Died Monday* was published in late February.

Geri Trotta '35







On the dais: left to right—Mary E. Walser, senior, Sarah Lawrence College; Dr. Francis M. Crowley, Dean, School of Education, Fordham University; Mrs. Paul E. Love, representing Mount Holyoke College; Dr. Eugene Youngert, principal, Oak Park and River Forest High School, Illinois, and Professor Mark Van Doren, of Columbia University. Dean Millicent C. McIntosh addresses the group.

# PROGRESSIVE EDUCATION:

## Forum Points to Middle Path

**B**ARNARD's fourth annual Forum on The Modern School: Evolution or Revolution played to a full house of 1300 men and women gathered together for the purpose of working out together the problems of traditional and progressive education patterns in today's life.

"The philosophy of teaching in our schools underlies the fabric of our society and the happiness of our homes," said Dean Millicent C. McIntosh in her opening remarks to the group at the Waldorf-Astoria on February 16th.

"We often hear of the 'attack on the public schools,' or of the 'battle' that is being waged among educators, parents and citizens as to what should be included in the curriculum. I submit that these words are misnomers—that there can be no 'attack' and that there should be no 'battle' among people of good will. Those who truly care for the welfare of our children and for the future of our society can reconcile their differences."

• • • First speaker was Professor Mark Van Doren of Columbia University, who spoke in support of the traditional in elementary training: "the skills of reading and writing,

the grammars, both literary and mathematical. Store their minds with the materials most absorbable then and most usable later: historical, geographical facts; literary, and mathematical texts, memorized for future use."

• • • Speaking on "Education for Democracy," Dr. Ernest O. Melby, Dean of the School of Education, New York University, said: "We have failed to understand that we cannot have true education without democracy. Our problem is to develop the educational program that gives us the release of power we need.

"We need a different kind of teacher—one who knows people as well as facts, who understands the community as well as books, and one who is as at home in the world of things of the spirit as in the world of material affairs.

"We must move beyond the confines of the schoolroom and the campus to mobilize the resources of the total community converting it in all its on-going life into an educational enterprise."

• • • Mrs. Mortimer Rothschild, member of the Board of Education, Scarsdale, answered the question

"What do Parents Want?"

"If you trust in the past as the guide for all good then surely you could shout 'Modern Schools—Revolution.'

"If on the other hand you believe as I do that the past experiences and culture of man are a common heritage and bond, that a knowledge of the past is needed for an interpretation of the present, that education should employ the techniques of modern science, and that it is the promise of a better world, then you'll not denounce modern education or the principles on which it is based."

The understanding of the give and take of group living and the responsibilities of citizenship in our democratic society should be learned at the same time as the 3R's, she pointed out.

• • • Speaking on the same subject, Mortimer Smith, author of *And Madly Teach* said "parents want a school which knows its functions and its limitations—one which transmits the intellectual heritage and knowledge of the race and in the process teaches children to think—a sizeable task in itself.

Should the physical, moral, personal, and vocational problems of



the children be the teacher's task too? Mr. Smith thought not, but was rather concerned with a truly liberalizing education which "makes one's mind a pleasant place in which to spend one's leisure."

• • • Dr. Wilson Parkhill, headmaster, Collegiate School, New York City spoke on "Traditional, Progressive or Both."

"I am sure that all of us agree that the experience and wisdom of the past should be studied. In this, I include religion. In our desire to separate church and state we have erred on the side of a godless education."

"Most college professors cry on my shoulder about the inability of students to write or even read. Their advice to beknighted school people is 'Stick to Fundamentals. Do more work in English composition and foreign language, history and, please, some geography.'"

• • • Dr. Eugene Youngert, Principal, Oak Park and River Forest High School, Oak Park, Illinois, noted:

"All youth comes to the public high school, and we who serve them accept gladly the injunction to work with all for the benefit and according to the capacity of each. To be a good school, the public high school had to understand, first, that all men are created equal; and to learn, at the same time, that all men are not created identical. Each must be educated according to his need and ability."

• • • Dr. Francis M. Crowley,



Left to right: Barbara Hewlett '48 and Helen Pond McIntyre '48.

Dean of the School of Education, Fordham University, said that "the rapid spread of the activity movement has resulted in confusion in education. There are good features inherent in it and we don't want the old order restored, but the progressive educator must realize that too much activity is unwise in a nation known for its passion for work. Contemplation of the beautiful, the good and the true still appeals to man. The overstimulated child may be the mental patient of the future."

Two students rounded out the four-hour forum on education.

• • • Mary E. Walser, Senior, Sarah Lawrence College, told about her experience at a progressive day

school, a public high school and a traditional boarding school.

She praised the "sound progressive school. Its aims were to teach us to use our minds, to get along with other people, to handle our feelings in a healthy way, and to be physically fit."

"Classes were small, the project method was used and enjoyed, and creative ability developed naturally. The public school, I attended, was made up of large classes where teaching had to be directed toward the least able pupil. The boarding school aimed at getting us into college, by establishing rigid control over our lives and using drills and

*(Continued on next page)*

Left to right:  
Wilhelmina  
Haake '52,  
Theodora Baldwin '00,  
and Alice Kohn  
Pollitzer '93.





(Continued from page 13)

tests in small classes to develop rational faculties.

"Progressive education is the indispensable pioneer—a trail blazer in the field of education," she concluded.

• • • Sylvia A. Bacon, Junior at Vassar, originally from the mid-West, feels the schools should produce alert, pioneering individuals by teaching the student to think by means of a body of pertinent material at his disposal. Secondly, self-reliance must be developed by self-government, student councils and extra-curricular activities. The educational community should emphasize opportunities for education beyond their immediate geographical limitations.



Helen Goodhart Altschul '07, whose gift establishing the Millicent Carey McIntosh Professorship in English was announced at the Board of Trustees meeting on February 13.

## College Gets \$150,000 Gift To Renovate Milbank

Resolutions establishing the Millicent Carey McIntosh Professorship in English, the Barnard College Club of New York Scholarship Fund, and the Edna Phillips Stern Scholarship Fund were passed at the February 13 meeting of the Board of Trustees. The trustees also approved acceptance of an anonymous provisional gift of \$150,000 to renovate Milbank Hall.

The Millicent Carey McIntosh Professorship in English was established in accordance with the wishes of Helen Goodhart Altschul '07, with the understanding that \$10,000 will be paid annually by Mrs. Altschul, and that the principal to endow the professorship will be contributed at a later date. For two years Mrs. Altschul was national chairman of the Barnard Development Fund. She is a member of the Executive Committee of the Board of Trustees.

### N. Y. Club Gives \$29,377

Members of the Barnard College Club of New York have given \$29,377 to the College through the Development Fund, and have pledged an additional \$3,103 to be paid during the next year. The two-fold distribution of the money will be as

follows: \$10,000 to be used by the College towards the reconstruction and redecoration of the entrance to Milbank Hall and \$19,377 to establish the Barnard College Club of New York Scholarship Fund, with the understanding that subsequent payments on pledges by members of the Club be added to the principal of this fund. The income of the fund is to be used to pay the full four-year tuition of some deserving Barnard student whose home is outside the New York area.

### Seminar Space Provided

The Edna Phillips Stern Scholarship Fund was established by Siegfried Stern in memory of his wife, the late Edna Phillips Stern '09. Mr. Stern and friends of Mrs. Stern gave gifts amounting to \$3,080 to start the scholarship fund.

The anonymous gift of \$150,000 will help with alterations of Milbank Hall and the remodeling of some classrooms into office and seminar space. The gift is contingent upon the College's raising the rest of the money necessary for rehabilitating Milbank Hall, which was built in 1897. Plans are now being made for the alteration, but no cost estimate has been announced.

## Buy Ways

Ranking as one of the world's leading newspapers, The New York Times recently celebrated 100 years of consecutive publication. Worth buying at any newsstand! . . .

Dating back to 1863 and today under its present name doing business with 200,000 people a year, Merrill Lynch, Pierce, Fenner & Beane, realize that the modern woman wants to know for herself why, where and how to place even small amounts for investments. They'll answer all your questions. . . .

A pupil of Salzedo, and graduate of the Juilliard School of Music, Mary Seiler gives fascinating recitals. Her informal talks are illustrated by selections on the harpsichord, and a group of folk songs, including early American ones, are accompanied by the Irish harp. A note for program chairmen. . . .

### "Brother and Sister Camp"

Margaret Fox Castonguay '34 represents a camp which will take both "brother and sister" on Lake Champlain. (Not too far from your home if you live in the metropolitan area.) It's called Old Furnace Point Camp. . . .

Frances Gedroice Clough '27 is adding two tennis courts this year to her camp Echo for Girls, on Raquette Lake, N. Y. in the Adirondacks. She says, "Whether climbing Blue Mountain, picking blueberries, fishing off docks, or rehearsing, Echo campers are having fun." . . .

Our advertisers are interested in Barnard Alumnae and they help support our magazine. Patronize them! And be sure to let them know that you saw their ad in your own magazine.

### Alumni Federation of Columbia University

I am writing to express the pleasure I have had in reading the February issue of your steadily improving magazine. Some solid work has been put into it, and you and your associates deserve a great deal of credit.

Congratulations and success to your efforts.

Morris W. Watkins  
Executive Secretary



# INTERNATIONAL PLAN FOR HEALTH

by Helen Shire Ascher '21

Representative of the World Federation for Mental Health

THIS story began for me in 1948 when I went to London with the UNESCO delegation to the Third International Congress on Mental Health, which brought together over 2,000 participants from fifty countries. I had no idea that I was on the first stage of a fascinating journey—not so much geographic, as intellectual. It was to deal with the development of an international voluntary organization to treat in a new way the problems of mental health and human relations. The emphasis was to be upon the affirmative possibilities of the emerging science of human relations, not merely upon mental illness. Thus the chief role of the World Federation for Mental Health is international planning for preventive work.

To carry out this aim, the Federation calls upon some sixty member associations and societies in more than thirty countries. They comprise nearly 1,000,000 people technically trained in professions as diverse as medicine and psychiatry, psychology, sociology and social work, nursing, education, cultural anthropology, theology and political science.

## Publish Bilingual Bulletin

The chief activities of the Federation are the publication of a bilingual Bulletin; the promotion of research; field trips throughout the world to promote or strengthen national mental health societies; and the organizing of training institutes.

A three-week, residential seminar will be held in Chichester, England, in the summer of 1952, devoted to the mental hygiene of the period of earliest infancy. The World Health Organization has offered a financial grant and thirty fellowships. The National Mental Health Council (U.S.A.) has granted \$15,000 for preparatory studies. UNESCO is expected to provide some support.

The Seminar will train relatively senior persons engaged in public health, education and child welfare administration, so that they can organize similar educational ventures in their own countries. One of the objects of study will be ways of modifying community practices harmful to desirable infant development.

The London Congress in 1948 was heartwarming because for the first time after the war it re-established communication between mental health workers from all over Europe and America.

I recall a Dutch psychiatrist who had spent fourteen months in the Belsen-Bergen Concentration Camp; his hardships first under the German occupation of Holland and then in the camp had left unforgettable marks and memories.

The most recent Congress was held in Mexico City in December, 1951. The host country outdid itself in the splendor and warmth of its hospitality to the 900 delegates from 48 countries and three United Nations organizations. For the first time, the Catholic Primate of Mexico attended the inauguration of a secular professional Congress, and his representatives exchanged views on mental health and religion with scientists of many faiths.

For a week the Congress dealt with the acute problems of transplanted and uprooted people; education and educational standards; the mental health of industrial workers; procedures for group treatment; new developments in preventive and curative therapy for children and young people, mentally ill adults and healthy adults; and measures to decrease tension and anxiety in modern life.

One of the first projects that the Federation would initiate if it had the needed funds would be an International Institute of Mental Health. Its purpose would be to provide interprofessional training for high level personnel engaged in mental health and human relations activities. Training in these professions today at existing institutions, more especially in some countries, is rather narrowly conceived in terms of work in one country, one profession or set of techniques.

## Proposed Institute to Train

A secondary purpose of such an Institute would be to provide short training courses for persons engaged in international collaboration whether in intergovernmental agencies or in work for international voluntary organizations. The results of such training might well lead to a sharpened awareness of cross-cultural and interpersonal problems as they are reflected in international organizations and conferences, that would gradually lead to more effective international discussion and cooperation.

In retrospect, I see how well Barnard prepared me for work as representative of the Federation at the Economic and Social Council of the United Nations. A course in anthropology with Professor Franz Boas gave me a basic understanding that there were important values in every society and that any notion of inherent superiority of one race or nation over another was false. Professor Ogburn's courses in sociology strengthened this understanding. I look back on exciting courses in history, drama, psychology as contributing to my background, and the influence of Dean Gildersleeve shaping Barnard students as world citizens.



# Safeguards For a Child's Health

by CAROLINE A. CHANDLER, M.D. '29

EVERY parent wants his child to be healthy at all times. By helping to prevent disease you help your child to keep well.

One of the most common and frequently one of the least easily recognized obstacles to health is malnutrition. People seldom think of irritability as being a symptom of a poorly balanced or inadequate diet. Because fatigue is a feeling everyone knows, we tend to accept it as such, when it may point to a nutritional lack that could be remedied. Actually, a child who is malnourished may be getting plenty of good food, but not the sunlight, or outdoor play or the fun out of life that puts his food to work for him.

A child also needs a clean and happy home, proper clothing, and plenty of sleep.

We do not know how to prevent all childhood diseases but we do know how to prevent some of them.

## Accidents Cause Most Deaths

For example, scurvy is a deficiency disease caused by lack of enough vitamin C. By giving a child sufficient amounts of orange or tomato juice, which are good sources of vitamin C, scurvy is prevented. Rickets can be prevented by giving a child sufficient fish-liver oil to supply him with vitamin D. Pellagra, beriberi, and other diseases due to deficiency of vitamin B complex can be prevented by seeing that a child gets a good diet containing whole-grain or enriched cereals or bread, milk, fresh vegetables, eggs, and meat. Vitamin A deficiency, which may cause night blindness and other eye disorders, can be guarded against by including plenty of whole milk, butter, and eggs in the diet.

## High Rate of Drowning Among Boys

More school age children die every year from accidents than from appendicitis, pneumonia, and heart disease put together. First in number come deaths from motor vehicle accidents. Next in order, but far below, come deaths by drowning especially among boys. Other causes of fatal accidents are burns, conflagration, injury by fall and, among older children, injury by firearms. We have succeeded in drastically reducing the death

rate from acute infectious disease and even from tuberculosis, but have hardly reduced the fatalities from accidents at all.

With all the foregoing in mind, what should you do to keep your family healthy?

1. See that everyone gets a well balanced diet consisting of three meals a day. This means a *real* breakfast as well as lunch and dinner. Included in the daily diet should be meat, eggs, poultry or fish; green, leafy vegetable; potato or another vegetable; citrus fruit; milk or milk product; whole grained bread and cereal; butter or fortified margarine.

2. Make sure that your child gets plenty of sleep, sunshine, outdoor exercise and time to have fun whether it be reading, playing games, listening to the radio or watching television.

3. Have your child immunized against smallpox, diphtheria, whooping cough and tetanus. Different pediatricians have different schedules. But a schedule recommended by the American Academy of Pediatrics is that the first injection of combined diphtheria and tetanus toxoids and whooping cough vaccine (three in one) be given at 3 months of age; the second at 4 months; the third at 5 months. Booster doses of this triple combination should be given at one year, 3-4 years, and every 3 years until the child is 9 or 10. Smallpox vaccination is given initially at 6 months of age and thereafter every 5 to 6 years.

## Plan Your Own Play Yard

4. Take steps to see that children have safer places to play. For example, in some cities parents have insisted on roping off certain streets for sliding so there is no danger of sleds colliding with cars. Or make your own yard more attractive to them by putting up parallel bars and swings, and letting the children build their own shacks.

Try to teach your child to obey traffic rules. This is best accomplished by setting a good example yourself!

Make sure that your child learns how to swim and knows how to give lifesaving aid.

Instruct your children in the proper use and respect, for guns. Even if you don't allow your own child to have a gun, he's bound, sooner or later, to go out with a neighbor's child who owns a BB or a "22", so be prepared.

5. Finally, to keep your family healthy, cooperate with your schools, PTA's and other agencies concerned with children in promoting dental, sight, and hearing conservation programs in the schools and child guidance clinics in your community.

---

. . . Dr. Chandler graduated from Barnard in 1929 and received her M.D., cum laude, from the Yale School of Medicine in 1933. She was research fellow in pediatrics at the Harvard Medical School; assistant dispensary pediatrician at Johns Hopkins Hospital and is now assistant professor of preventive medicine and instructor of pediatrics at the Johns Hopkins School of Medicine. She is the author of several juvenile books and frequent contributor to scientific and medical journals.



# Case History

## of a Young Intern



Muriel Chevious, M.D. '46

by MURIEL CHEVIOUS, M.D., '46

JUNE 7, 1951 was an incredible day. That was the day an urchin from Flatbush received an M.D.

I'm not quite sure how it happened. But I believe it had something to do with her interest in people, the way they behave, and why. Being somewhat secure in the notion that mind is a function of matter, she set out to study that most important bit of matter, the human body.

After four years of study, she wasn't sure she really understood the matter, let alone its function. But she was pleased that she was one of the lucky who had been prepared to study this problem further. This day was also a sobering occasion in the life of the urchin, for attached to her degree, were numerous strings,—the responsibilities of a member of the medical profession to the community.

### Despaired of Seeing Patients

My four years of medical school are only months behind me, but already I am reminiscing. The first year was unbelievably dull. So much of the subject matter seemed to be a study of static structure; i.e. assorted anatomy courses. There was gross anatomy, developmental anatomy (embryology), microscopic anatomy (histology), and neuroanatomy. So many hours were spent peering through a microscope, that I almost despaired of ever seeing a patient.

The second year was a great improvement. Perhaps the "patients" in whom we studied various drug effects and wound healing were only dogs or cats. But at least they were patients of sorts. This seemed like a step in the right direction! And then there was the glorious third year, when you were permitted on the ward to be molded into a "clinician," a practitioner of the art of medicine, and not just a "lab worker."

### Wonderful to Recognize a Peptic Ulcer!

The fourth year was an extension of this aspect of our training. One almost achieved a feeling of responsibility, being delegated to draw blood samples, start transfusions, deliver an occasional baby, etc. And it was especially satisfactory to "work up" a new patient. "Working up" a patient meant to take a complete medical history, examine the patient, on the basis of your findings make at least a tentative diagnosis, and make recommendations for further diagnostic procedures and treatment.

Time would usually prove your diagnosis right or wrong. How wonderful to recognize the presence of a

peptic ulcer! You knew then that the four years were well spent. But when you confused an anxiety neurosis with hyperthyroidism! Fortunately, there were always the more experienced on hand to help you reconcile yourself to the fact, that for some things, experience was not just the best teacher, but frequently the only teacher.

At present, I'm an intern. And in many ways, I know I've just begun to learn medicine. I learned a good deal from books and working in laboratories. But one of the greatest assets a physician can have is good judgment. It can't be learned from books, but only from contact with patients.

There are times when I feel that the price of this extended education is a little expensive. It costs long hours of toil, the day's work often extending far into the night, day after day, and on week-ends, too. Of course, we are acquiring valuable experience and information which could hardly be obtained otherwise. I sometimes wonder, however, if in some respect, an internship is not something of a "miseducation" as well as an education. A physician must know medicine well. But he must know more. Must he not be acquainted with the culture, psychology, and economics of his patient in order to really understand? Some of this information can't be learned within the cloistered confines of a hospital.

### Need for Trained "G. P.'s"

Internships vary a good deal as to the type of training they afford. Mine gives six months of training in pediatrics, psychiatry and medicine each, and three months each in surgery and obstetrics-gynecology. This internship was originally devised for people who are interested in the general practice of medicine. I know there is a great need in many communities for well trained "G.P.'s." But I shy away from this field because "to be broad is to be shallow, and to be deep is to be narrow." It seems to fit my particular personality to be somewhat narrower in order to be a little deeper.

As an intern, I look back over four and a half mostly enjoyable and satisfying years. And because of those past years, I look ahead to a more secure future—emotionally, intellectually, materially. I hope I am not too naive in believing that this security is at least one ingredient of a happy life. I trust that I am not being too selfish, because I feel that my happiness and security will be, in part at least, founded upon some contribution to the happiness and security of others.



# THE FOLKLORE OF

by PATRICIA A. LANGWELL '43

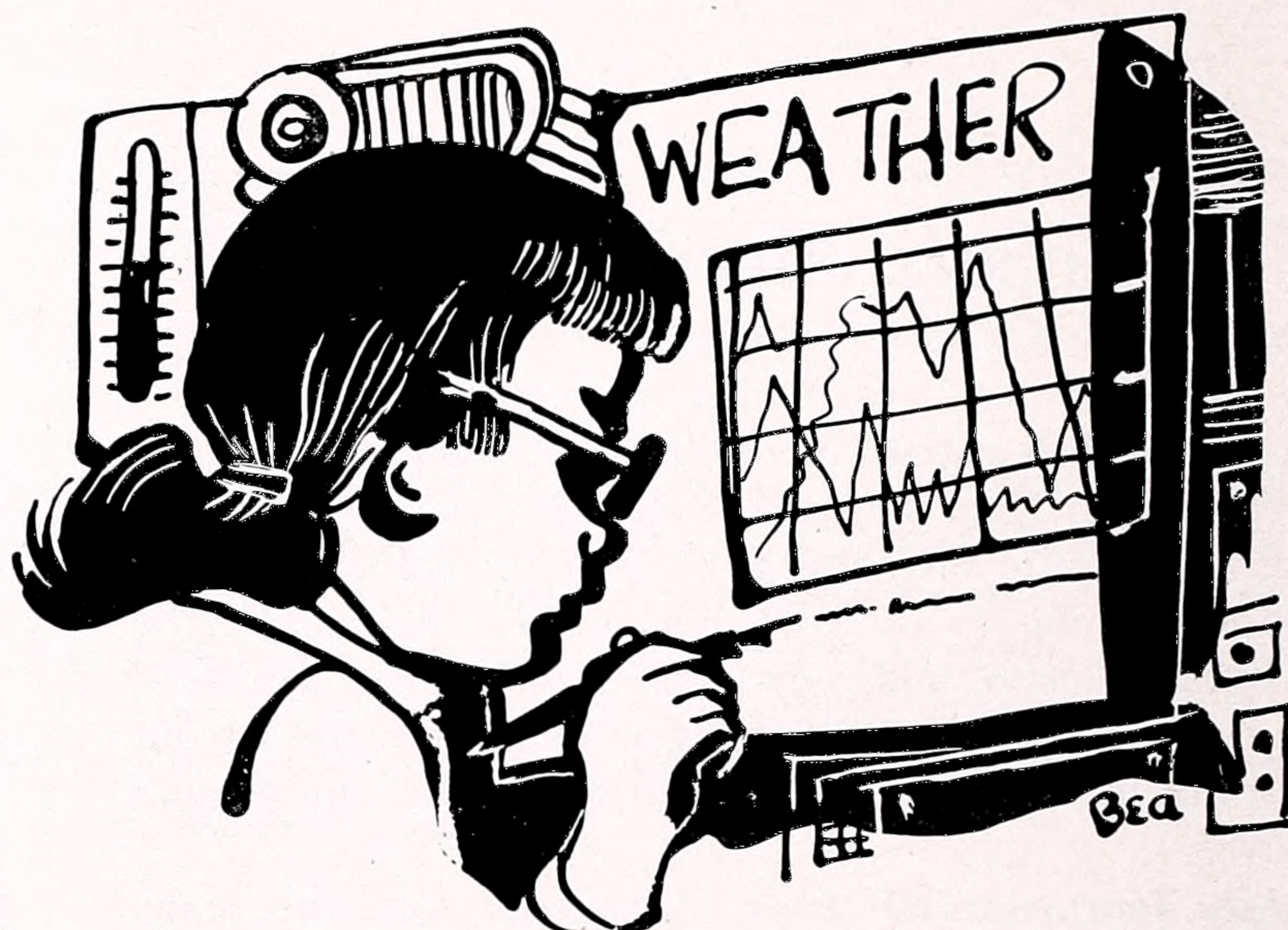

SINCE the water shortage and New York City's much-publicized efforts at rain-making, the average person is much more aware of meteorology as a science. As a result, WEather 6-1212 has become one of the more popular telephone numbers in the city. The professional forecaster now enjoys the status of "scientist" instead of scapegoat for spoiled picnics and curtailed ball-games of only a few years ago.

Actually, weather forecasting has not improved so much in that short time. It is merely better advertised. If you read the forecast in this morning's paper, you are almost as likely to get your shoes wet and your hat ruined as you were before the war.

## Sniff of Air a Good Guide

This new and improved status of the scientific weatherman should not make you disparage the old farmer and the grizzled seaman. These local characters are often worthy competitors of the machine-minded technicians. What the professional cannot always achieve with his teletypes, maps and instruments, these worthies can often do with a mere sniff of the air and a glance at the sky.

Of course, their forecasts are not as detailed as those of professionals. They are only interested in whether

it will rain or whether it will be clear. Their techniques consist of a collection of rules of thumb, old saws, and proverbial wisdom. Not all of these rules are equally good, but some of them are useful to an untrained forecaster.

## Aching Corn May Be Barometer

Everyone has a friend whose aching corn or painful rheumatism is claimed to be an infallible guide to the weather. It may not be infallible but it is at least as good as the old family barometer. Medical men and meteorologists working together have conducted elaborate experiments with the help of actual sufferers. Their formal conclusions have verified what everyone has known for a long time: that corns and rheumatic limbs ache before it rains. Corns act as little barometers. They ache when the pressure is falling and this is usually the prelude to rain.

Farmers have no instruments. Instead, they must use what they see around them, the way smoke blows out of a chimney, the height preferred by birds in flight, the twisting of the leaves in the wind. This last is a particularly good sign of rain. The wind in this country blows mostly from the west. As a result, the trees grow up leaning into the wind, much as people will brace

themselves when walking in the face of a strong wind. Rain winds, however, sneak up on the trees from the east and cause the leaves to flutter in a way that makes them seem to blow inside out. As you can see, those who depend on this kind of forecast are usually right.

## Ring Around the Moon

There is another rule of thumb that usually works. It is the well-known chestnut about the ring around the moon. This is so famous it is familiar even to city people. When the moon at night wears a halo, it is usually a sign that a large storm is approaching. Clouds of fair weather usually disappear (evaporate) at night. Storm clouds are stronger, unfortunately, and live longer. The particular clouds which give the decorative effect to the moon are not the usual storm-clouds, —large, menacing thunderheads. They are thin, high-level alto-stratus which themselves do not become rainclouds but are merely prophets of rain.

"Red skies at night, sailor's delight; red skies at morning, sailors take warning." Sailors who used this saw probably wound up in Davy Jones' locker. At any rate, it has no truth in it. Neither has the optimistic "Rain before seven; clear before



eleven." It may be that this saying at first referred to fog rather than rain. In that case, it would have been true. Although there is very little fog in New York, when it does appear before breakfast, it mostly burns off by lunchtime. I have heard it said that if there's enough blue in the sky to make dutchmen's breeches, it will clear. But, largely because of the lack of information about this kind of garment, I have been unable to apply any scientific test to this rule.

### Radio Forecasts Best

Naturally, these rules are not likely to be of much help to urban cliff-dwellers, because they are not as closely in touch with the weather and with the signs that foretell it as country people. Of course, anyone may have corns or rheumatism, but city people don't see the moon except on the way to the subway nor have leisure to observe the flight of birds or the blowing of the leaves. To the city dweller the weather is not something observed; it is something felt, an intrusion on the peaceful passage from home to office and vice versa.



Since they cannot use their own ingenuity, our city folk have to depend on the weatherman. To make the best use of what he has to say, you should remember that the best forecast is the one that tries to tell you what will happen in two hours rather than in two days or two months. Thus the longer ago the forecast was compiled, the less accurate it is likely to be. That is why radio weather forecasts are the best. They are changed hourly and take account of what has happened to the weather during the past hour. This the forecast in this morning's paper cannot do. One word of warning. Don't expect perfection. The weather changes too rapidly and the forecaster is only human.

Gretta McOmbler Sciutto and Margaret Egbert Thompson '24 have co-authored *In the Very Name of Christmas*, a nostalgic collection of traditional Yuletide recipes, customs, decorations and the like, recently published by Chapman and Grimes, Inc. of Boston. Mrs. Thompson boasts a real farm in Claverack, New York, with cows, chickens, rabbits, cats and dogs. Her family includes her husband and five children. . . . Barnard is the only New York institution among 21 cooperating colleges to support a training program for elementary and secondary school teachers at the Harvard Graduate School of Education . . . Sheldon and Eleanor Touroff Glueck '19 have had their latest book, *Delinquents in the Making*—Paths to Prevention, recently published by Harper and Brothers . . . Jeanette Hendrickson, pretty red-haired student at Barnard, gave up a continental adventure for more book learning. She was social secretary to Stanton Griffis, American ambassador to Spain until this fall, when she returned to the U. S. to enter Barnard. . . . Dean Millicent C. McIntosh is the first woman to be elected to the Board of Trustees of the American Museum of Natural History. "She has earned a remarkable reputation for making learning a dynamic part of living," said Alexander M. White, the Museum's president. . . . For the 1952-1953 academic year, daughters of electrical workers will be eligible for four-year scholarships at Barnard. This educational program launched by the Joint Industry Board of the electrical industry in 1949 is a unique effort instituted by labor and management. . . . Katherine Shea Condon '23 is replacing Henrietta Swope '25 as treasurer of the Scholarship and Loan Fund. . . . Lucyle Hook, assistant professor of English, will give a lecture-concert on early 17th century music with members of the Juilliard School of Music at 8:30 P.M. on April 3rd at the Folger Library in Washington, D. C., and on April 5th at the Colonial Mansion in Williamsburg, Virginia. A

choral and instrumental group of nine in colonial costumes will accompany Miss Hook on the Williamsburg program. . . . The first annual Alumnae Council established by the Alumnae Association to bring alumnae leaders back to the campus to learn first hand the developments at Barnard gets under way Friday and Saturday, March 14 and 15 at the College. . . . *Ye Gods*, a two-act original musical written and produced by the Junior class, packed Brinckerhoff in its two night stand on February 29 and March 1. Choreography was under the direction of former Roxyette, Joan Stecker, and featured a modern dance-ballet with a take-off on the Barnard library. . . . Among new faculty members for the spring semester are Dr. John Reich, professor of English; Dr. Elizabeth Nottingham, visiting associate professor of sociology and Howard Sharpe, visiting lecturer in economics. . . . *A History of Jazz in America* by Barry Ulanov, instructor in English, was published by Viking in late February. . . . Professor W. Cabell Greet, on leave for the spring semester, will sail for France to study on a Guggenheim Fellowship. . . . **Coming for April:** An entertainment issue with articles about Barnard's theatrical shining lights—Leora Dana '46, Aline MacMahon '20 and others. . . . Rosemary Casey '26 writes of Pittsburgh's experimental theatre group. . . . Harriet Berg '48, real-life daughter of radio and TV's "Molly Goldberg," tells about life with Mama. . . . And there's a picture story on Greek games marking the 50th annual performance at Barnard on March 29th. . . .

F. S. P.

### A note for your calendar!—

GREEK GAMES, Saturday, March 29, at 3:00 P.M.—A limited number of tickets at \$1.25 are available to alumnae. Send your check, payable to the Greek Games' Committee, to the Alumnae Office, 301 Barnard Hall.



# Clubs Coast to Coast

## — Spring Programs —

### Westchester Will Hold Benefit Fashion Show

The Barnard College Club of Westchester will hold its annual scholarship benefit bridge and fashion show to raise funds in the early spring, according to an announcement by *Eloise Hoctor Sage '23*, program chairman. Over \$225 was raised last fall for the scholarship fund. *June Crollly Dickover '40* will be the general chairman for the event.

Professor Douglas Moore of the Barnard Music Department will be the guest speaker at the May meeting, the details of which will be announced in the club bulletin.

### Duplicate Bridge at New York Club

Joseph A. Lettman, chairman of education for the Investment Association of New York, addressed club members on the "Functions of the Stock Exchange" at the January 31 meeting. *Martha Lawrence Wieners '41*, assisted by *Elisabeth Foye '42*, was the chairman of the event.

During February the club featured two duplicate bridge parties, one under the chairmanship of *Vora Jaques '10*, the other under the chairmanship of *Helena Archibald Waller '24*, and a junior party with *Josephine Castagna '39* and *Patricia Evers Glendon '46* in charge. On March 1, the club held a bridge and canasta party.

A meeting of the Board of Directors preceded by a talk and demonstration of flower arrangements by *Lois Saphir Lee '40* is planned for Monday, March 10, and a couples' game night on Saturday, March 29.

### Marian Smith At Philadelphia

The Barnard Club of Philadelphia invited the guidance councilors of the public and private schools of the Philadelphia area to meet Marian Smith, Barnard's director of admissions, at a tea held in the Women's University Club on January 16. Barnard alumnae were invited to bring friends who had daughters approaching college age. Miss Smith spoke on Barnard's policy of admission.

Barnard alumnae attending the tea were: *Katharine Browne Stehle '25*, *Virginia Brown Kreuzer '29*, *Roslyn Stone Wolman '31*, *Edith Kirkpatrick Peters '30*, *Albertrie Gahen Becker '30*, *Sari Fenyo Kalish '29*, *Alice Newman Anderson '22*, *Edna Stahl Cousins '26*, *Mary Barber '18*, and *Martha M. Greene '50*.

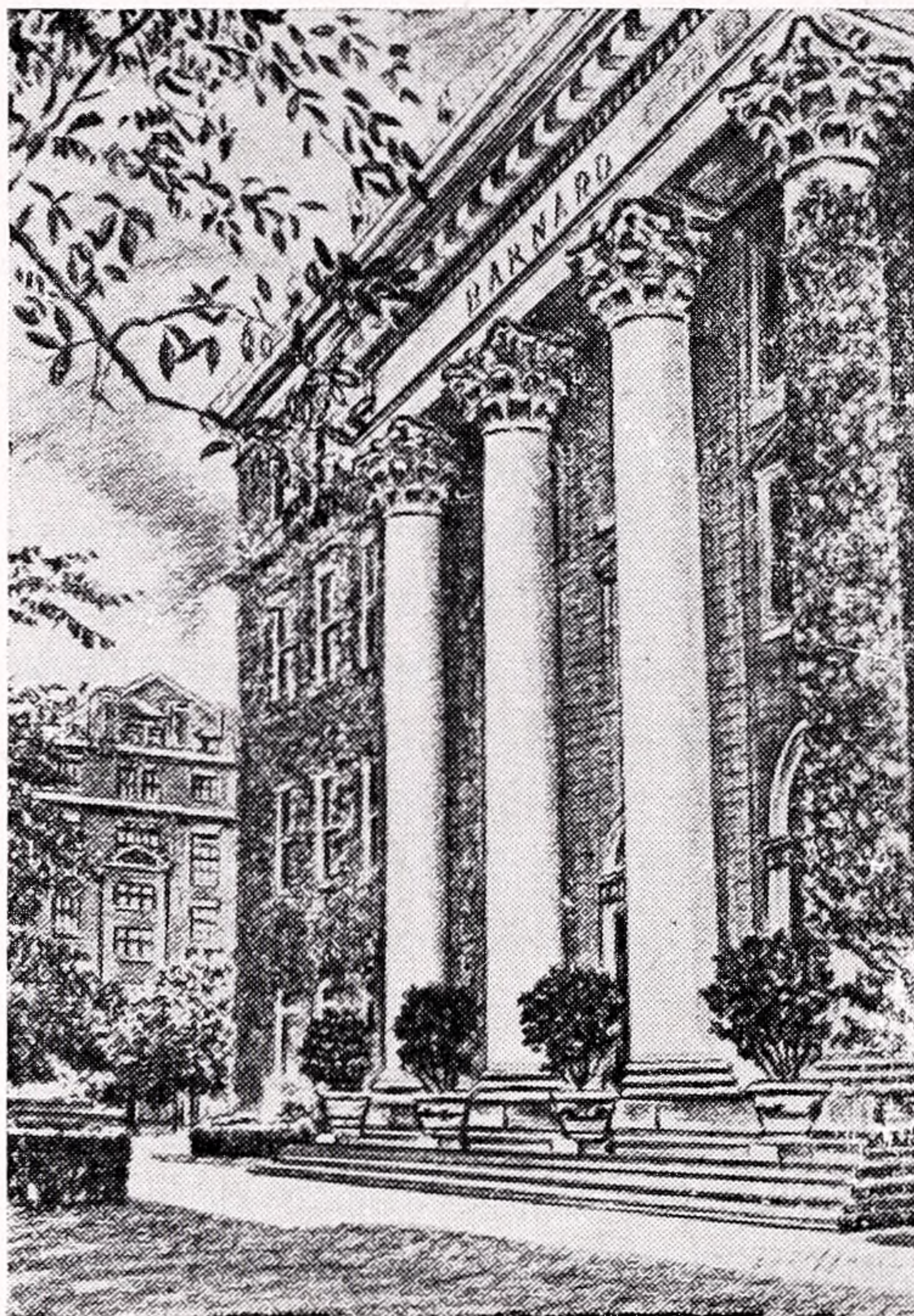

### San Francisco Talks of Community

*Edyth Fredericks '06*, *Mathilde Drachman Smith '21* and *Fannie Bach Parsons '32* and *Marion Washburn Towner '18* represented the club at a conference on the place of women in community life sponsored by Mills College on January 21 and 22 to celebrate its 100th anniversary. Margaret Hickey, public affairs editor of the *Ladies' Home Journal*, was the principal speaker and the panel included men and women active in community life in the Bay area.

### Dean Gildersleeve Fairfield Member

The Barnard College Club of Fairfield County held an executive board meeting on January 18 at the home of its president, *Gladys Slade Thompson '13*, in Greenwich. The June meeting and future activities of the club were discussed.

Dean Emeritus *Virginia C. Gildersleeve '99*, and Professor *Elizabeth Reynard '22* have accepted the club's invitation to be honorary members.

### Boston Attends 7 Colleges Conference

Before the annual conference of the Associated Alumnae of the Seven Colleges on January 26 at the Hotel Statler, members of the Barnard College Club of Boston met for luncheon at the Junior League of Boston.

Alumnae attending were: *Katherine Battley '48*, *Katherine Decker Beaven '20*, *Lois Brean '49*, *Dorothy Kirchwey Brown '10*, *Winifred Scott Dorschug '31*, *Mary Ellen Hoffman Flinn '48*, *Miriam Peabody Gale '48*, Dr. *Eleanor Touroff Glueck '19*, *Alice Goebell '19*, *Ellen Haight Hawkes '46*, *Diane Howell '44*, *Dorothea Johnston Hutchins '40*, *Eleanor Tibbetts Lehman '31*, *Ruth Mehrer Lurie '24*, Dr. *Gulli Lindh Muller '17*, *Olga Ihseng Nunan '11*, *Louise Stabler Parker '93* and *Dorothy Davis Pratt '37*.

HOLDERS of International Grants studying in Boston will be guests at a March 12th meeting at the home of *Mildred Williamson Johnston '25* at 8 P.M.

### Thrift Shop Talk For Brooklyn

The midwinter meeting of the Barnard College Club of Brooklyn was held on Tuesday, February 26, at the home of *Carrie Fleming Lloyd '10*. The program featured a talk on the Barnard Thrift Shop by *Dorothy Graffe Van Doren '18*, chairman.

A dessert bridge will be held at the Barnard College Club of New York on Saturday, March 15, under the chairmanship of *Ada Shearon '35*. On Saturday, April 26, the club will hold its fifteenth anniversary luncheon at the Montauk Club. Dr. *Lucie Petri '14* is chairman.

**YOU can play the Irish Harp!**  
Easy to learn, lots of fun. Ideal for children and folk song accompaniment.

#### MARY SEILER

Lecture-recitals, teaching  
149 E. 73rd St. REgent 7-0027

**Spring opening!**  
**Time for that new hat! From \$16.50**  
Busy women given special attention.

*Elizabeth Schuler*  
58 E. 53rd St.—PLaza 3-5789



# Class News: 1901—1951

• '01

**Died:** *Eda Kunz* on December 28 in New York City.

• '04

*Lucy Embury Hubbell* had an article, "The Arab and his Culture," published in the October issue of *Think* magazine. Her last book was *The Golden Footfall*.

• '06

*Josephine Paddock's* painting, "Soap Bubbles," was exhibited in January at the National Academy of Design in New York City in the show of the Audubon Artists.

• '12

**Died:** *Emma Rapelye Somerville* on October 13.

• '13

*Gladys Slade Thompson* was elected this winter to the Women's Auxiliary of the New York Academy of Sciences.

• '14

*Florence Palmer Edgell* was elected in January as the executive director of the Millburn-Short Hills, N. J., chapter of the Red Cross.

• '15

**Died:** Dr. *Agnes Conklin*, psychiatric social worker and member of the New York City public school system for more than 35 years, on February 3 in Brooklyn.

**Other news:** *Dorothy Skinker Hooker*, who moved to Tuscon, Ariz., from White Plains, N. Y., six years ago, has written that her son, a graduate of the University of Arizona, is now working in Tuscon and her daughter is a senior at Pomona College.

• '16

**Died:** *Carol Weiss King*, attorney specializing in immigration and citizenship cases, on January 21 in New York City. At the time of her death, she was the head of the law firm Carol King and Blanch Freedman.

**Other news:** One of the participants in the panel discussion "Inside Israel" on December 19 sponsored by the Mamaroneck-Harrison-Rye, N. Y., chapter of Hadassah was *Jean Jacoby Beckman*.

• '17

*Edmund S. Lewis*, husband of *Ruth Wheeler*, died on December 3.

"Greetings and Congratulations!

The Barnard Monthly, always a fine publication, has become more interesting than ever.

Enclosed please find check.

Elizabeth V. Rabe  
Barnard '20"

• '21

*Deborah Kaplan Mandelbaum* played the butler in *Minus the Highness*, the junior show of the class of 1921 mentioned in the February issue of the *Alumnae Monthly*.

• '23

*Louise Brown*, employment director at National Screw & Manufacturing Company and member of Personnel Women of Cleveland, participated in the 11th Northern Ohio Personnel and Executive Conference at the Hotel Cleveland on January 18.

• '24

After serving for twenty-three years as director of fund raising and publicity of the Seamen's Church Institute of New York and as editor of the group's magazine, *Marjorie Candee Houck* retired in January to do free-lance writing.

• '25

A retrospective exhibition of 30 paintings by *Maud Cabot Morgan* was displayed at the Farnsworth Museum, Wellesley College, during January and February. The exhibition included one of her earliest works, "Victorian Chair," as well as her latest, the unfinished "Large Yellow." Her paintings can be found among the permanent collections of the Metropolitan Museum of Art, the Whitney Museum, and the Museum of Modern Art in New York.

*Henrietta Swope*, treasurer of the Students' Loan Committee of the Alumnae Association for the past four years and former associate in the Columbia astronomy department, is now at the Mount Wilson and Palomar Observatories in Pasadena, Calif.

• '29

**Married:** *Phoebe Atwood Taylor*, author of numerous detective stories, to Dr. Grantley W. Taylor in Boston on December 28. He is a visiting surgeon at the Massachusetts General Hospital and an assistant professor of clinical surgery at Harvard Medical School.

• '32

**Married:** *Barbara Bent* to Roy C. Bates.

• '34

Captain *Lidie Venn*, formerly a civilian employed as a psychologist at the Air Force Human Resources Research Center, San Antonio, Texas, is now a supervisor in the aptitude measurement division of the Personnel Research Laboratory, also in San Antonio.

At the January meeting of the Hazleton, Pa., chapter of the American Association of University Women, *Eugenie Bigelow* discussed the structure, achievements, and failures of the United Nations.

• '36

"I sincerely believe that a mother needs all the education she can get, and I'm glad I have mine!", *Sonya Turitz Schopick* said in a recent letter to Mrs. Elizabeth Baker, professor of economics at Barnard. Her background has enabled her to be of service to various community organizations in Bridgeport, Conn., such as the League of Women Voters or the Citizens' Committee to study the Bridgeport Public Schools as well as help her to train her three small children.

• '37

**Born:** To Robert and *Garnette Snedeker Kroeger* their fourth child and third son, Robert Snedeker, on January 17 in Norwich, N. Y.

Dear Mrs. Petruzzi,

I'm not given to the writing of fan letters but I feel that I must tell you how very much I've enjoyed the last two issues of the *Alumnae Monthly*.

I always used to devour the old *Alumnae Magazine* for news of a "gossipy" variety but I think I envied my husband's "John Hopkins Magazine" for its articles of broader outlook. Now I feel we're on a par.

Sincerely,

Leonore Schanhous Krieger '38



# What good is \$500?

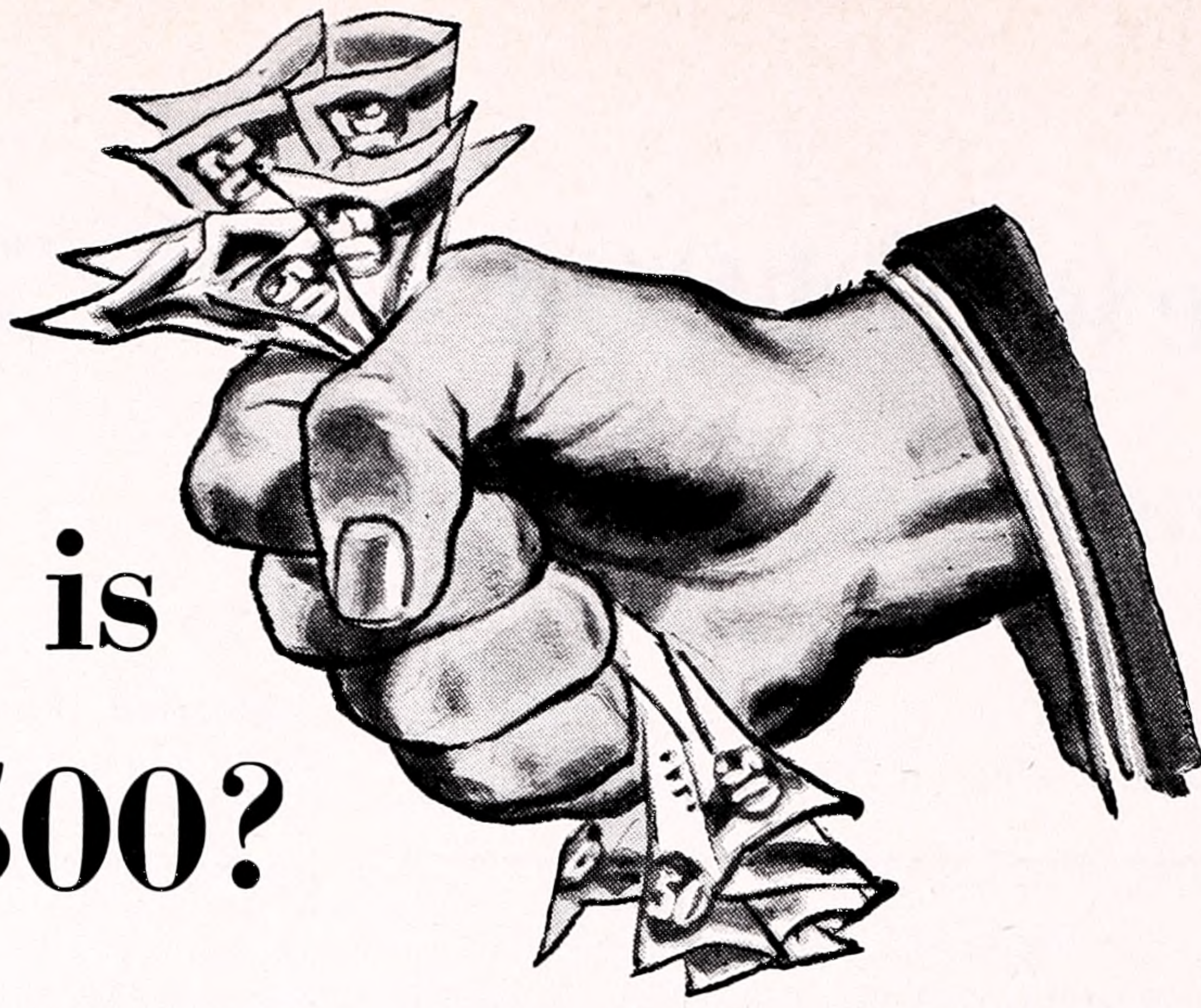

*"Sure, I'd like to invest. Who wouldn't? But I'm no millionaire. I do manage to save a little, sure. Maybe \$40 or \$50 a month over and above what I need for living expenses, insurance, and emergencies. But the most I could spare right now is \$500—and what good is that? You can't get rich on a couple of shares of stock, so I guess I'll just have to wait . . ."*

And that's how it goes with thousands of people each year who could start on a sound investment program — *but don't*. And that's too bad.

Why? Well, for one thing, \$500 buys a lot more than you probably think. You see, stock values don't always depend on price. A stock selling at \$40 a share, for instance, can easily be as good a buy as one selling at \$80—often a better buy.

As a matter of fact, \$40 a share is just about the average price of all the 1,054 common stocks traded on the New York Stock Exchange. So on the basis of that average, your \$500 would buy at least 12 shares of stock, and you'd be entitled to whatever dividend was paid on those shares.

How much would that be? That's hard to say. We could point out that last year 9 out of 10 of those stocks paid dividends that averaged over 6%, but that's no guarantee for next year or the year after that. The same thing is true of stock prices. They can go up or they can go down in any given year.

But investing is a long-term business, and on that basis it's good business for any man with extra dollars — a good business to begin at any time.

Why? Well look around you. Look how American business has grown in 10 years, 20 years, 50 years. That's why investors — the stockholders who own American business—have prospered.

Yes, we think investing is always good business. But it's better business for the investor who selects stocks or bonds carefully—on the basis of facts and information, not rumor or tips.

And that's where we may be of help to you. Tell us about your situation, and we'll tell you, without any obligation, what we think makes the best kind of an investment program for you, whether you already own securities or not. Just write — in confidence, of course, to . . .

Department MK-6

**MERRILL LYNCH, PIERCE, FENNER & BEANE**

70 PINE STREET, NEW YORK 5, N. Y.

Offices in 97 Cities



## • '38

**Born:** To Gordon and *Elizabeth Pratt* Rice their second child and first daughter, Johanna Elizabeth, on February 1.

## • '39

**Born:** To Walton and *Helen Rome* Marsh a daughter, Barbara Leslie, on October 19. Her brother, Donald, was born in May, 1950.

**Other news:** *Janet Davis* Lynn is studying at Johns Hopkins for her Ph.D. in political science.

Friends Center—144 East 20th St.  
New York 3

Committee for International Students  
and United Nations Personnel

Dear Friend,

The international emphasis of the December-January issue of the *Monthly* was arresting and delightful. I feel impelled to write not only to voice my approval, but also to let the foreign students at Barnard and the interested alumnae know that this committee exists for the purpose of encouraging home hospitality for foreign students.

*Lucy Karr* Milburn '17 is a member of this committee, and I, *Rachel Souhami de Leeuw* '27, and its executive secretary.

## • '40

**Died:** *Mary Harter* Duncan in November.

**Married:** *Charlotte Wigand* James to *Clare J. Hoyt*, Cornell University and Yale Law School graduate, on January 12. Formerly district attorney of Orange County, N. Y., he is now a member of the law firm, Scott and Hoyt, of Newburgh, N. Y.

**Other news:** The present address of *Joan Thonet* Hall and her husband, Commander *Chester G. Hall Jr.*, U.S.N., is Staff, Comnavestlant, Navy #100, F. P. O., New York, N. Y. They have two children, Judith and *Chester G.*, 3rd.

## • '42

**Born:** To *Elliott* and *Marion Blum* Sweet their first child, Barbara Kathleen, on October 22.

## • '43

**Married:** *Marion Bromilow* to *Bert Mendelson*, a Columbia and University of Nebraska graduate, on January 5. He is now studying for his Ph.D. at Harvard University.

*Elfriede Thiele* to *William Gordon* Kelso in May. They are living in Baltimore.



**Born:** To Edward and *Grace Glass* Marwell their third child and second son, David George, on December 31.

**Other news:** *Edythe Jeffrey* Warren is a substitute teacher in the Chapel Nursery School, Bronxville, N. Y.

• '44

In the New York State psychological intern training program, *Martha Messler* is supervisor of psychological interns at Letchworth Village in Thiells.

• '45

**Married:** *Margaret Bunce* to Lt. Peter Kenmore. They are to be located in Germany.

**Born:** To Arnold and *Marcia Barishman* Paulen a son, Eugene Herbert, on January 16.

**Other news:** *Shirley Fischer* Morgan is a secretary with I.B.M. in Long Beach, Calif.

*Celine Young Felson* is writing armed forces news scripts for the Voice of America.

While doing part-time research for the New York City Board of Higher Education, *Margaret Greene* is studying guidance and school counseling at Brooklyn College.

• '46

**Born:** To Paul and *Emily O'Connor* Pernice their second daughter, Carolyn Marie, on January 19.

To William and *Lorna Pitz* Bunte their second daughter, Nannette Helen, on November 13. Her sister, Pamela Anne, was born October 26, 1948.

**Other news:** *Mary Ruth Goodwin* of Staten Island has been commissioned a second lieutenant in the WAFS and is now at Lackland Air Force Base in San Antonio, Texas, for an eight weeks' indoctrination course after which she will be assigned to an Air Force squadron.

*Jenny McKean* Moore, whose husband is one of the rectors of Grace Church in Jersey City, spoke at a meeting of the Women's Auxiliary of the Church of St. James the Less in Scarsdale, N. Y., on January 7.

In Wilmington, Del., *Isabel Schetlin* McNeil is a case worker with the Family Society.

*Phyllis Vipond* From is a research chemist with the Davison Company in Baltimore, Md.

• '47

**Married:** Dr. *Claire June Moore* to Dr. Hugo M. Cardullo, a captain in the Army Medical Corps, in June. She received her M.D. degree from New York University in June.

**Born:** To Carl and *Maria Bontempi* Fogelin their first child, Julia Adrian, on August 28.

To James and *Betty Green* Knap a daughter, their second child, Susan Alice, on January 26, at Camp Lejeune, N. C.

To Frederick and *Joan Borowik* Sobel their first child, Andreus Mark, on January 2. Her husband is a project engineer with the Friez Instrument Division of Bendix Aviation Corporation.

**Other news:** *Jacqueline Shumaker*, a teacher in Mount Kisco, N. Y., is planning to conduct a six or eight week sight-seeing tour through Europe this summer.

• '48

**Married:** *Roberta Tunick* to Dr. Gerald H. Kass, alumnus of the University of Pittsburgh and the New York Medical College, Flower Fifth Ave. Hospitals, on January 18 in New York City. He is on the house staff of Montefiore Hospital.

*Marjorie Steele* to Jean-Claude Maurice. At present they are living at the Grand Hotel des Balcons, 3 Rue Casimir, Delavigne, Paris VI, France.

*Elaine Mauger* to Ralph E. Waters, Jr., who is on the district engineer's staff of the long wires department of the American Telephone and Telegraph in Boston, on September 22. Their home is in Providence, R. I.

*Janet Wright* to George W. Sullivan Jr., a Middlebury College graduate, on December 30. He received his M.A. from Brown University and is now doing further graduate work there.

**Born:** To Gregory and *Beverly Lister* Webb a son, James Mackenzie, January 8.

To Eliot and *Mary Frank* Farley their first child, Eliot Farley 3rd, on December 13.

To Richard and *Nancy Bartlett* Wing a daughter, Susan Elaine, on August 28.

To William and *Jean Reiser* Arrow-smith a daughter, Nancy, on November 19, 1950. Nancy's father is an instructor in classics at Princeton University.

**Other news:** *Eileen Evers* is an attorney with Emmet, Marvin and Martin in New York City.

*Ramona Thelander* is assistant to a regional director at the Institute of International Education.

*Marilyn Gledhill* Shafer is secretary to the secretary-treasurer of the Ford Foundation.

• '49

**Married:** *Elizabeth Pauly* to The Reverend William A. Rowen. Their home is in Buffalo, N. Y.

*Natalie Cole* to Gordon R. Hamilton Jr. Address: 20 Oliver St., Salem, Mass.

**Born:** To Nathaniel and *Patricia Roth* Hickerson their second child and first son, Jonathan, on December 23.

**Other news:** *Marilyn Ward* de Leeuw has moved to 525 Rand St., San Mateo, Calif., with her husband, who recently received his discharge from the Marine Corps, and their son, Michael John, born on November 5, 1950. Her husband is now the manager of the San Francisco

office of Paul de Vries, Inc., diamond importers.

*Helen Fredericks* Sabo is secretary to Rabbi Hoffman at Columbia.

*Janet Cherry* is studying for her M.A. in christian education at Windham House, national graduate training center for Episcopal women, in New York City.

While on a six months' leave of absence as assistant librarian at the New York Historical Society, *Rosary Scacciaferro* is going abroad with her mother *Giuseppina Mina Scacciaferro* '24. They are

## Camp Guide —

### OLD FURNACE POINT CAMP

#### Westport on Lake Champlain

For boys and girls 6-14 yrs. Modern screened cabins; private lav., hot showers. Limited enrollment permits individual care. Sports instruction. Riding optional.

\$395 season \$210 half-season  
Includes medical care and laundry.

Catalogue on request.

**Mary V. Fox**, Director, TA 9-4655  
2147 Haight Ave., New York 61 N. Y.

**Margaret Fox Castonguay**, '34,  
16 Hunter Drive, West Hartford, Conn.

### ECHO CAMP for GIRLS

#### Raquette Lake, N. Y.

A summer of fun and adventure on a large lake in the Adirondack Mountains.

**55 girls 6-17 \$385**

Director

**Mrs. Frances Gedroice Clough**, '27

176 Edgewood Ave. Pleasantville, N. Y.

### THE CALHOUN SCHOOL

Founded 1896

*A College Preparatory Day School for Girls, 7th through 12th grades. Small classes, thorough academic training, fine faculty, extra-curricular activities.*

Headmistresses

**Elizabeth Parmelee**, *Vassar*

**Beatrice S. Cosmey**, *Vassar*

309 West 92nd Street New York 25  
Telephone RIverside 9-4222

### FARD-BOBELLE

French dressmaker, designer

**Gowns, suits, coats**

549 Riverside Drive, Apt. 5D

Call Mon.-Tues. A.M. MO 6-2510



joining Rosary's father who is chief sanitary engineer with a branch of the Army in the Mediterranean area.

• '50

**Died:** Nancy Karl in January.

**Married:** Mary Louise Clark to David A. Smith.

Margaret J. Rogers to Benjamin Sanders. Address: Van Bree Straat 74, Amsterdam, Netherlands.

Helle Jensen to R. H. Krentell. Their address is Caixa Postal 200 B, Sao Paulo, Brazil.

**Born:** To Milton and Helene Hersch Granet a daughter, Harriet Beth, on January 21.

**Other news:** Muriel Magnusson is a secretary with the Honeycomb Company of America, Inc., manufacturers of aluminum honeycomb for airplane and guided missile fabrications in Mount Vernon, N. Y.

Marguerite Maier is assistant to the director of public affairs of the National Federation of Business and Professional Women's Clubs.

Helen Anderton is assistant to the head of the information counseling department of the Institute of International Education.

In Wilton, Conn., Rita Ann Graham is a personnel assistant and secretary at the Remington Rand Inc. Laboratories

of Advanced Research.

Virginia Riley Hyman is a secretary with the Gardner Board and Carton Company in New York City.

Phyllis Maloy Murphy is secretary to Dr. Rustin McIntosh at Babies Hospital, New York City.

• '51

**Married:** Dorothy Minton to John D. Crist, a graduate of Colgate University and now a senior at The Theological Seminary in New York City, on January 26. She is a secretary with the United Protestant Church.

**Born:** To Nolan and Gertruda Brooks Lushington their first child, Christopher Brooks, on January 24 at Camp Lejeune, N. C.

**Other news:** Margaret de Vecchi sailed in January for the Hague, Netherlands, where she will serve as personal secretary to U. S. Ambassador Selden Chapin.

Gladys Bogat is a secretary in the Haitian consulate in Miami, Fla.

Lieutenant Dorothea Storck is a member of the 3002 WAF Squadron of Olmstead Air Force Base.

Mary Jordan Cox is a typist and editorial assistant with the publications division of the U. S. Department of State.

Linda Howe is working at the Viking Press, New York City.

Carol Vogel is secretary to the manager of the New York Doubleday Bookstores.

At the Institute of International Education, Doris Clarke is a regional associate and Janet McKee Silard is an assistant in the information counseling department.

Adrienne Colabella is a receptionist with the Ford Foundation.

Carol Burnham is a copy writer for the Compton Advertising Agency.

Alma Besso is a staff assistant in the women's activities department of the National Tuberculosis and Health Association.

In Pittsburgh, Marion Bell is doing volunteer publicity work for Animal Friends, Inc.

Norma Taylor is working at the Hospital for Sick Children in London, England, and will be a second year student at the Royal Free Hospital School of Medicine next fall.

BARNARD CLASS NEWS AND CLUB NEWS are prepared by Mary Roohan Reilly '37, executive secretary of the Associate Alumnae, 301 Barnard Hall, Barnard College, New York 27, N. Y. Please send her all pertinent information about yourself, your family and career, as well as photographs you would like fellow alumnae to see in your magazine.

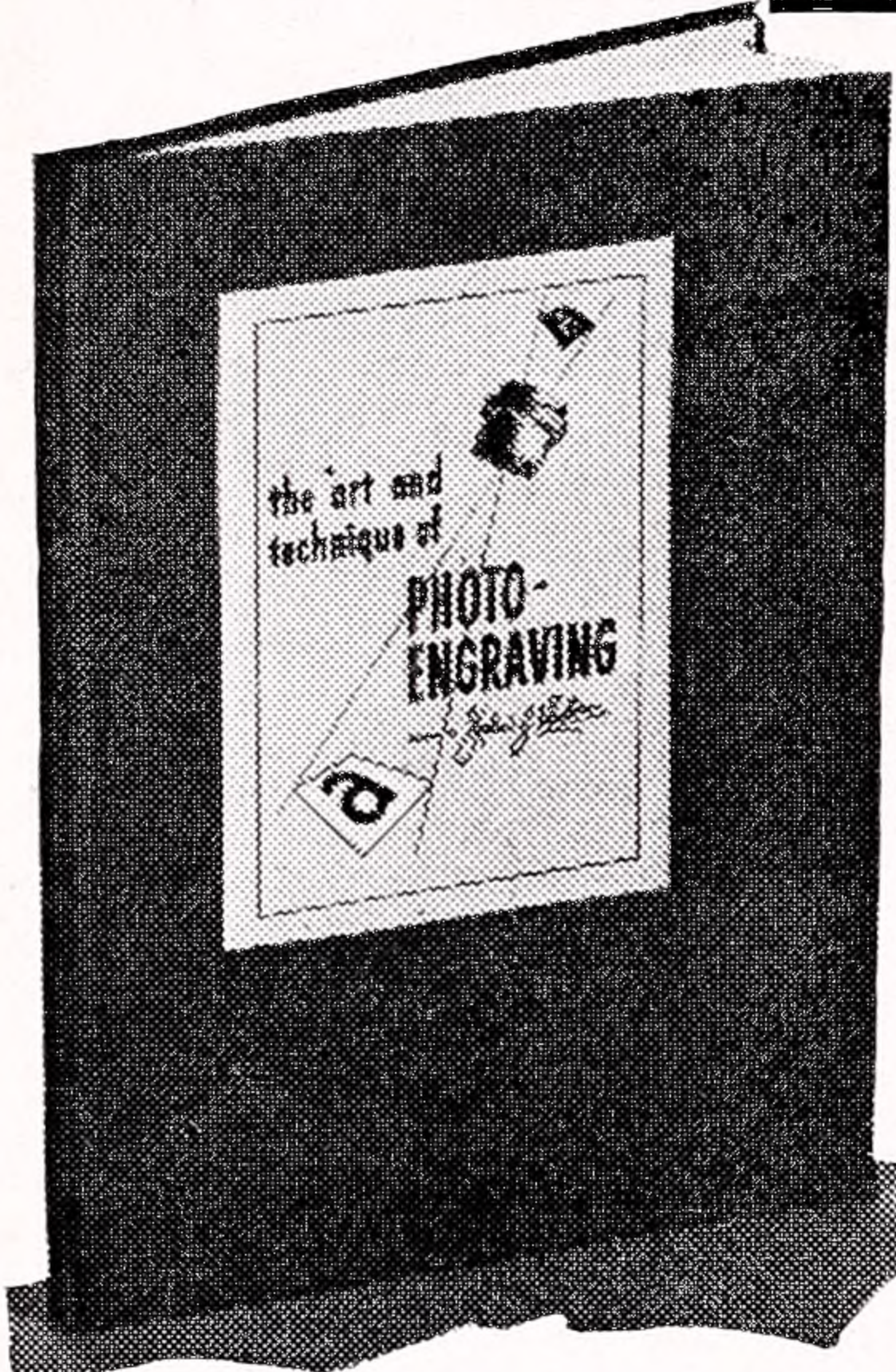

# GET THE FACTS about Photo-Engraving!

Price only \$2.00 postpaid.

Black & White, Benday & Color Process

Answers to hundreds of photo-engraving questions are available to you now, in 108 pages—lavishly illustrated in black and white, and color. Just drop us your check or money order in the next mail.

**HORAN ENGRAVING COMPANY, INC.**  
44 WEST 28th STREET, NEW YORK 1, N. Y.  
Telephone MU 9-8585 Branch Office: MArket 2-4171  
"24 HOUR SERVICE"

-----  
Please send me (prepaid) . . . . . copies of your 108 page revised book, "The Art and Technique of Photo-Engraving."  
My check for \$ . . . . . is enclosed.  
NAME . . . . .  
STREET . . . . .  
CITY . . . . . STATE . . . . .

## Printer's Ink says:

" . . . we think many advertisers overlook special and profitable groups in their eagerness to create a mass impact."

ARE YOU OVERLOOKING a group of women open to new ideas and who purchase intelligently?

BARNARD ALUMNAE MONTHLY is their own magazine. Here is a medium of unusual and intimate reader interest in which to tell your story at low cost.

Advertising Office, 3009 Broadway  
New York 27, N. Y.



# Candidates For Alumnae Board

THE Nominating Committee of the Associate Alumnae under the chairmanship of *Helen Jones Griffin '21* submits below for your consideration its slate of candidates to fill the vacancies on the Board of Directors and on the Nominating Committee of the Associate Alumnae for the terms indicated.

As stated in Article XII, section 2, of the by-laws, nominations may also be made by petition of not fewer than twenty members of the Associate Alumnae who shall come from at least four different classes, if filed with the chairman of the

Nominating Committee, 301 Barnard Hall, not later than Tuesday, April 1. Such petition must be accompanied by the written permission of the candidate.

The ballot as prepared by the Nominating Committee, and incorporating independent nominations, will be mailed to all alumnae in April.

The slate of candidates proposed by the Nominating Committee is:

## Candidates for the Board of Directors 1952-1955

First vice-president — *Frances Smith '32*  
Treasurer — *Dorothy Funck '29*  
Chairman, Advisory Vocational Committee — *Louise Odencrantz '07*

Chairman, Publications Committee — *Dorothy Woolf Ahern '28*  
Director at Large — *Anne McLaren Stevens '36*  
Director at Large — *Margaret Mather Mecke '49*

## Candidates for Nominating Committee 1952-1955

(three to be elected)

*Doris Goss '27*  
*Cornelia Merchant Hagenau '31*  
*Jean Moore '50*

*Marion Heilprin Pollak '12*  
*Alice Webber '15*  
*Joy Lattman Wouk '40*

1952-1953

(one to be elected)

*Lucy Appleton Garcia-Mata '36*

*Lois Boochever Rochester '49*

The qualifications for each candidate in the Nominating Committee's slate are listed below. The qualifications include

### • *Frances Smith '32*

**Undergraduate:** secretary, treasurer, president, Undergraduate Association; president, freshman class; **Alumnae:** former member, Nominating Committee, Board of Directors, Committee on Reorganization of Alumnae Association; **Community:** member, Advisory Committee, Brooklyn Urban League; member, Executive Committee, Brooklyn Management Club; play reviewer, Catholic Theater Movement; **Business:** director of industrial relations, Murray Manufacturing Corporation.

### • *Dorothy Funck '29*

**Alumnae:** treasurer, Associate Alumnae; **Community:** president, Women's Bond Club of N. Y.; member, Research Committee, Association of Bank Women; past president, Zonta Club of N. Y.; **Business:** assistant vice president, Irving Trust Company.

### • *Louise Odencrantz '07*

**Alumnae:** former chairman, Students' Loan Committee; chairman, Advisory Vocational Committee; class president; **Community:** chairman, Experimentation Committee, National Board, YWCA; member, Advisory Committee for Nurse Placement Service, New York State Employment Service; member, Social Studies Committee, New York State branch, A.A.U.W.

### • *Dorothy Woolf Ahern '28*

**Undergraduate:** costume chairman, sophomore Greek Games; art editor, *Mortarboard*; member, *Quarterly*; **Alumnae:** class secretary; member, Publications Committee; **Business:** assistant executive editor, *Newsweek*.

### • *Anne McLaren Stevens '36*

**Undergraduate:** chairman, Student Library Committee; member, Honor Board; **Community:** vice-president, Memorial Library of Radnor, Pa. Township; director, Main Line School Night Association; committee member, Wayne, Pa. town meetings on foreign policy; **Business:** parish secretary, Wayne Presbyterian Church.

### • *Margaret Mather Mecke '49*

**Undergraduate:** chairman, Curriculum Committee; delegate, Representative Assembly; chairman, town meeting; board member, Wigs and Cues; **Alumnae:** former captain N.Y.C. Development Fund; **Community:** former publicity consultant, Public Information Committee, Battle Creek, Mich.

### • *Doris Goss '27*

**Undergraduate:** president, junior class; vice-president, Undergraduate Association; **Community:** class agent, Brearley School; **Business:** philanthropic analyst, office of John D. Rockefeller, Jr.

the candidate's undergraduate, alumnae, community or professional, and business activities.

### • *Cornelia Merchant Hagenau '31*

**Undergraduate:** member, Business Committee, freshman Greek Games; poster chairman, sophomore and junior class; member, *Mortarboard*, Junior Show; **Community:** synodical treasurer, Women's Missionary Society of the Evangelical Lutherans Synod of N. J.; member, Executive Committee, Central Conference of the United Lutheran Synod of N. J.; member, Program Committee, A.A.U.W., Elizabeth, N. J.; member, Hospitality Committee, Battin High School, PTA, Elizabeth, N. J.

### • *Jean Moore '50*

**Undergraduate:** social chairman, residence halls; member, *Mortarboard*, *Bulletin*, Wigs and Cues; **Business:** art representative and mechanical artist, advertising studio, Lynn Graham Studio.

### • *Marion Heilprin Pollak '12*

**Undergraduate:** member, Wigs and Cues; **Business:** medical social worker, Babies Hospital; assistant director, social service department, Babies Hospital.

### • *Alice Webber '15*

**Community:** past president, American Association of Psychiatric Social Workers; **Business:** regional representative, Federal Security Agency, Social Security Administration.

### • *Joy Lattman Wouk '40*

**Undergraduate:** president, Menorah society; delegate at-large, Representative Assembly; business manager, *Quarterly*; costumes chairman, Greek Games; **Alumnae:** former director, Barnard College Club of N. Y.; former member, Alumnae Fund Committee; former captain, Development Fund; class agent, Barnard Fund; volunteer, Thrift Shop; **Community:** secretary, east side branch, Americans for Democratic Action; **Business:** free lance research editor, Grolier Information Service.

### • *Lucy Appleton Garcia-Mata '36*

**Undergraduate:** member, Greek Games Committee, Representative Assembly; **Alumnae:** former committee member, N. Y. C. Development Fund; member, Nominating Committee; **Community:** church worker, St. Marks Episcopal Church, New Canaan, Conn.

### • *Lois Boochever Rochester '49*

**Undergraduate:** president, Undergraduate Association; **Alumnae:** member, Nominating Committee; **Business:** teacher, general science, Riverdale Country School for Girls.



# COMING EVENTS

**Monday, March 10**

Barnard College Club of New York

3:30 P.M.—talk and demonstration of flower arrangements by *Lois Saphir Lee '40*;

4:30 P.M.—tea;

5:30 P.M.—Board of Directors meeting; Barbizon Hotel.

**Tuesday, March 11**

2:30 P.M.—Board of Directors of the Associate Alumnae meeting; 409 Barnard Hall.

**Friday, March 14**

5:00 P.M.—Alumnae Council: registration and reception of delegates; student annex.

8:30 P.M.—Wigs and Cues performance: "Bodas de Sangre;" tickets \$1.00; Brinckerhoff.

**Saturday, March 15**

10:00 A.M.—Alumnae Council sessions; college parlor.

1:30 P.M.—Barnard College Club of Brooklyn: dessert bridge; Barbizon Hotel.

8:30 P.M.—Wigs and Cues performance. (see above)

**Monday, March 17**

8:15 P.M.—Barnard College Club of Bergen County: second meeting in a series of four on theme "College Woman's Part in the Community;" guest speaker, Mrs. William Fairbanks of the Barnard government department; Girl Scout Little House, Teaneck.

**Tuesday, March 18**

4:00 P.M.—Junior class Jay Thorpe fashion show; admission 25¢; Brooks Hall living room.

**Saturday, March 29**

3:00 P.M.—Greek Games: admission \$1.25; send checks, payable to the Greek Games' Committee, to the Alumnae Office, 301 Barnard Hall; limited supply; Barnard gymnasium.

8:00 P.M.—Barnard College Club of New York: couples' night; Barbizon Hotel.

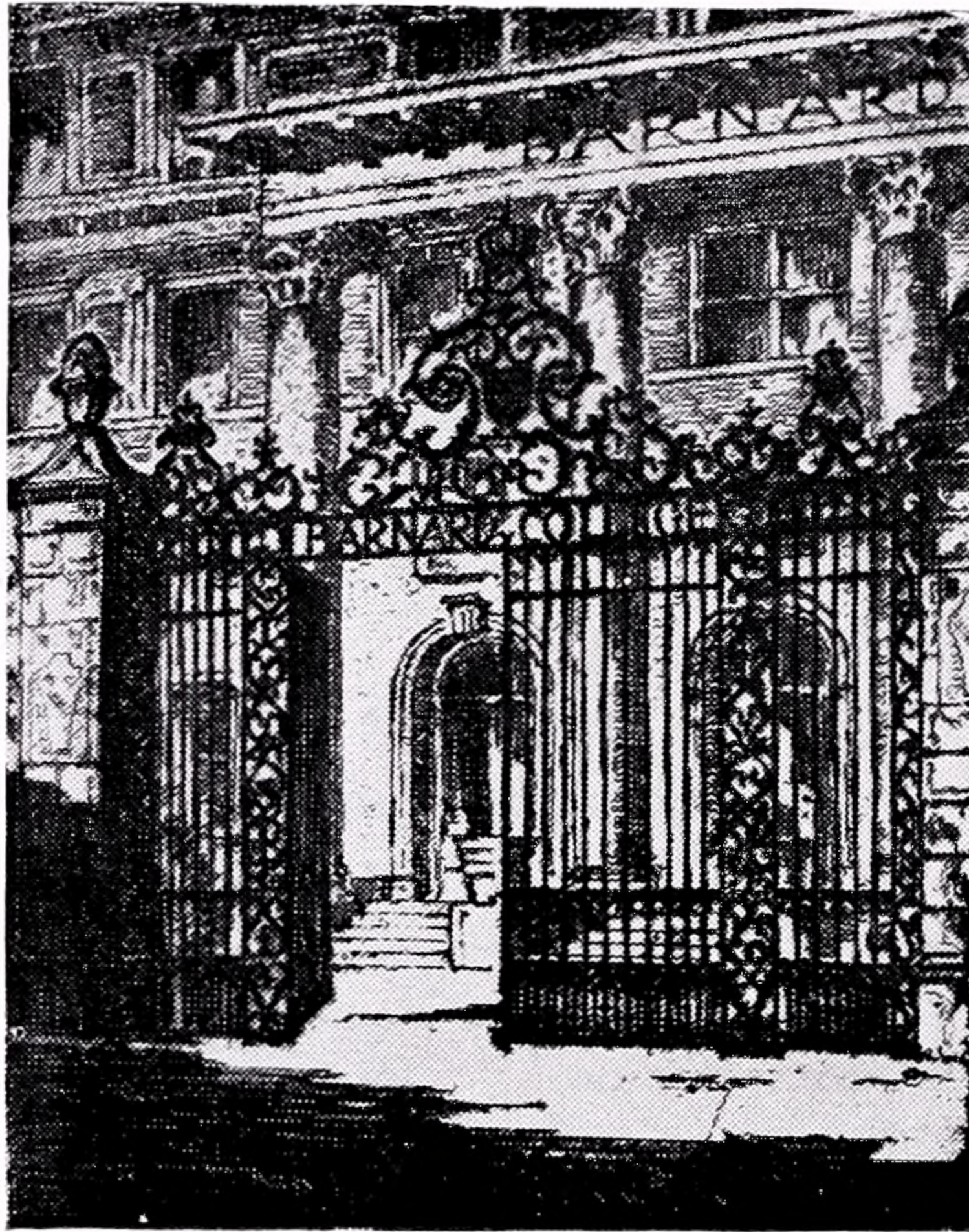

## Alumnae Council Calendar

### PROGRAM FOR DELEGATES

March 14 and 15, 1952

Barnard College

Friday, March 14

12:30 P.M. Dean's Luncheon to Regional Councillors  
Deanery

*Topic for discussion:* Barnard College  
What are its strengths and weaknesses? What would interest young people in your community so that they would choose Barnard rather than any other eastern college?

5:00 P.M. Registration and Reception for All  
Delegates Student Annex

6:00 P.M. Business and Orientation Meeting  
Student Annex

Madge Turner Callahan '26  
President, Alumnae Association  
*Presiding*

6:45 P.M. Buffet Supper (Reservations at \$1.50)  
Hewitt Hall

Eva Hutchison Dirkes '22  
First Vice President, Alumnae Association  
*Presiding*

"Why Barnard? Why My Major?"  
An Undergraduate

"What Does Your College Owe You?"  
Dean Millicent C. McIntosh

8:30 P.M. Wigs & Cues "Bodas de Sangre"  
(Tickets at \$1.00) Brinckerhoff

(in English)  
by Federico Garcia Lorca

**Saturday, March 15**

10:00 A.M. Discussion College Parlor

Dorothy Funck '29  
Treasurer, Alumnae Association  
*Presiding*

"Administering Barnard"

Jean T. Palmer

General Secretary

Marian Smith

Director of Admissions

Ruth Houghton

Director of Placement Office

11:30 A.M. Faculty-Alumnae Panel College Parlor  
"Gaps in My Barnard Education"

(Alumnae)

"Are We Filling These Today?"

(Faculty)

12:45 P.M. Buffet Luncheon (Reservations  
at \$1.00) Hewitt Hall

"Where Is Barnard Going and How?"

Margaret Gristede MacBain '34

Alumnae Trustee

2:30 P.M. Open House Deanery