

THE SCHOLAR AND THE FEMINIST XIII:

Women's Images
and Politics

Saturday, MARCH 22

1 9 8 6

8:30 am to 7:00 pm

A conference sponsored by
The Barnard College
Women's Center

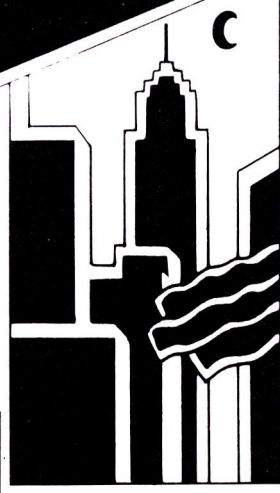
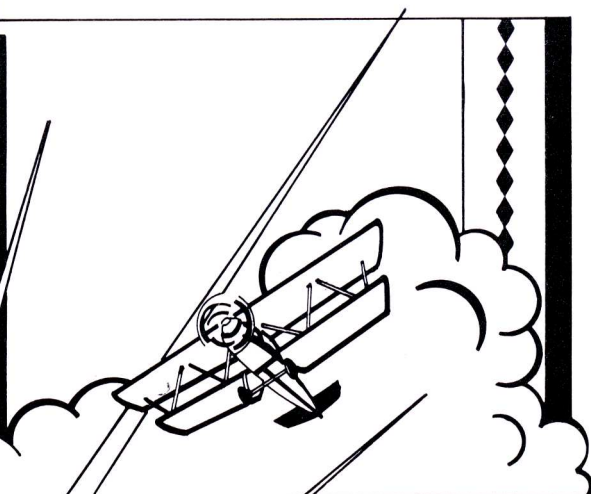

**Check-in at Barnard Hall
8:30-9am**

**MORNING SESSION
9am-12:30pm
Gymnasium**

Welcoming Remarks
Ellen V. Futter, President,
Barnard College

Conference Opening: "*Things Visible and Invisible: Representations of Women*," **Catharine Stimpson**, founding editor of *SIGNS*, Rutgers University

Film: "*Christopher Strong*," 1931, with **Katherine Hepburn**, directed by **Dorothy Arzner**

Commentary: "*The White Female Director in Hollywood: Arzner's Representation of Women in 'Christopher Strong'*," **E. Ann Kaplan**, Rutgers University

**Lunch 12:30 - 2 pm
MacIntosh Student
Center**

**AFTERNOON SESSION
2-6 pm**

**Afternoon Workshops
2-4:15 pm**

1. Images of Women's Studies and Politics in Spain
Aria Ballezbó, Spanish Congressional Deputy
Mary Nash, Director of the Center of Historical Research on Women, University of Barcelona, Spain
Mercedes Vilanova, University of Barcelona, Spain

2. Gender and Genre: Re-Presenting Representation
Bella Brodzki, Sarah Lawrence College, "*The Case of Autobiography*"
Celeste Schenck, Barnard College, "*The Case of Poetry*"
Louise Yellin, SUNY College at Purchase, "*The Case of the Novel*"

3. Media Access and Accountability: Poor, Working Women and Women of Color Creating a New Aesthetic
Katherine Ekau Amoy Hall, *Womanews*
Ada Griffin, *Third World Newsreel*
WomenImage Presentations by Poet **Hattie Gossett** and Actress **Bina Sharif** Film Clips

4. The Anorexic as Heroine: Eating Disorders and Feminist Politics
Kate Ellis, Rutgers University
Sonia Sayres, Cooper Union

5. Science Fiction and Political Imagination
The Feminist Science Fiction Study Group, *History of Consciousness*, University of California, Santa Cruz

6. Representation in Dance
Susan Leigh Foster, Wesleyan University
Susan Allene Manning, Columbia University
Cynthia Novack, Barnard College
Video

7. Images of Asian American Women: Myth and Reality
May Chin, Community Activist
Shirley Hune, Medgar Evers College
Renee Tajima, *Third World Newsreel*

8. Their Eyes Were Watching Icons: Feminists, Journalists, and Cultural Critics
Margo Jefferson, Critic, Journalist
Slides

9. Contradictory Images of Sexuality in Rock Videos on MTV
E. Ann Kaplan, Rutgers University
Video

10. Lesbian Mothers 'Choosing Children'

Cheryl Kennedy, Women's Alcoholism Program (CASPAR)
Julia Pérez, University of Massachusetts
Film

11. Women's Culture and Anti-Nuclear Politics

Ynestra King, Women's Pentagon Action
Lisa Miller, War Resisters' League
Genevieve Vaughan, Feminist International for Peace, Nairobi Peace Tent

12. Imaging Black Women: Hollywood and Black Independent Films

Phyllis Klotman, Director, Black Film Center Archive, University of Indiana
Slides and Film Clips

13. Teenage Pregnancy: "Love, Marriage, and the Baby Carriage?"

Janie L. Kritzman, The Barnard Women's Center, moderator
Monica Meyer, M.D., Adolescent Medicine, St. Luke's-Roosevelt Hospital Center
Deirdre Wulf, Editor, Family Planning Perspectives, Alan Guttmacher Institute

14. Figuring Woman: An Identity Crisis in Art and Popular Culture

Ellen Levy, Journalist
Ann Reynolds, CUNY, Graduate Center
Slides

15. Images in Action

Robin Michals, Painter, Muralist
Kristin Reed, Photographer, Painter, Muralist
Slides

16. Cause and Creativity: A Lecture/Screening with Black Feminist Filmmaker Michelle Parkerson

Michelle Parkerson, Founding member, Eye of the Storm Productions, Inc., Producer/Director of "Gotta Make this Journey: Sweet Honey in the Rock"
Video

17. Fetal Images: The Power of Visual Culture in the Politics of Reproduction (Viewing, Decoding, and Resisting "The Silent Scream")
Rosalind Pollack Petchesky, Author of Abortion and Woman's Choice
Video

18. Screening Stereotypes: Images of Disabled Women in Media

Susan Quinby, Office for Disabled Students, Barnard College
Jane Thierfeld, Access to Equity, Barnard College
Video

19. Apropos of the Legs of the Countess: Femininity and Celebrity in the French Second Empire

Abigail Solomon-Godeau, Photography Critic and Historian

20. Images of Women in Contemporary China

Marilyn Young, New York University

CLOSING SESSION

4:30-6 pm

Gymnasium

"Reconsiderations from the Perspective of an Historian,"

Joan W. Scott, Institute for Advanced Study, Princeton, New Jersey

Open Plenary 5:30-6 pm

Temma Kaplan, Director of the Barnard Women's Center, Moderator

RECEPTION

6-7 pm

MacIntosh Student Center

Conference Director
Temma Kaplan

Conference Coordinators

Carrie Emerson

Janie L. Kritzman

Bonnie Sheldon

Art Director

Marlene Weisman