

# BARNARD

ALUMNAE MAGAZINE / SPRING 1986



# LETTERS TO THE EDITOR

*The editors welcome your views on issues that we believe to be of interest to Barnard alumnae. Letters must be signed. We reserve the right to edit for length and clarity.*

## Let's Look to the Horizon

To the Editor:

I wish to support Janice Pries in her opinion expressed in her letter to you (*Alumnae Magazine*, Fall 1985) that it would be a contribution beyond our own pages to devote an issue to the cause of peace.

Surely there are many of us working to insure that this earth and the human race has a future. If the experience of Barnard gave us anything, it gave us broader horizons that influenced our choice of activities beyond careers, families, and recreation.

There are so many aspects to this topic: are there any Barnard alumnae in the UN, in education, in medicine, in mental health, etc., working for peace? If so, how: Is concern about the armaments race largely a generational matter? What do undergraduates think, feel, about the threat of a nuclear holocaust?

Thank you for your attention.

Lillian Mould, Ph.D. '35  
Westport, CT

To the Editor:

I do not believe the magazine should become a political forum. On the other hand, the idea of nuclear war is so unthinkable that one wonders how our elected leaders can not only think of it, but budget our taxes for it.

Opponents of nuclear arms among alumnae might find encouragement and support from knowing they are not alone.

On the other hand, would you have to give equal space to anyone who actually believes we should have this stockpile of kindling that could ignite the world?

Kathryn Heavey '35  
Kingston, NY

*Editor's Note: Once again, we invite alumnae who are involved in various aspects of the effort to save our planet from our own folly to share their experiences and thoughts with us.*

## Retirement Options & Opportunities

To the Editor:

The education community has given generously to the Peace Corps over the last 25 years. We appreciate and salute that commitment of time and talent, and turn to you now to help us pass on a message to still another segment of the college world — your alumnae.

We believe that your readers have been touched, as we all have, by changes in employment and lifespan which leave many of an age, but not of a disposition, to retire. These women may be surprised to learn that an active and expanding Peace Corps welcomes their interest as they leave the job market.

As always, Peace Corps is a highly selective band of volunteers — a very special group who  
*continued on page 19*

## BARNARD TRAVELS TO INDIA

January 1987

The Associate Alumnae of Barnard College invites you to travel with us to the fascinating and beautiful sub-continent of India. Accompanied by Professor Barbara Stoler Miller, chairman of Barnard's Department of Oriental Studies, we will sample the rich variety of regional cultures and landscapes of this vast nation. Our particular focus will be on art, dance, and religion.

Cities to be visited:

Delhi	Agra	Aurangabad	Madras
Khajuraho	Jaipur	Ajanta	Bombay

Probable dates: January 16-February 4. Watch your mail for detailed announcement.

Toni Crowley Coffee '56, editor  
Karen Jolkovski '80, assistant editor  
Dafna Abileah-Amrami, designer

### Magazine Advisory Committee

Margaret Zweig Lee '75, chairman  
Jill Alcott '85  
Shirley Frank '65  
Patricia Evers Glendon '46  
Michelle Marder Kamhi '58  
Esther Spilberg Novak '64  
Barbara O'Dair '82  
Michelle Patrick '71

### Associate Alumnae

Elise Alberts Pustilnik '53, president  
& alumnae trustee  
Francine du Plessix Gray '52, alumnae trustee  
Anna Quindlen '74, alumnae trustee  
Ruth Schachter Morgenthau '52, alumnae trustee  
Emily Gaylord '78, 1st vice president  
Joyce Pollack Montgomery '71, 2nd vice president

### Chairmen, Standing Committees

Harriet Kaye Inselbuch '62, Barnard Fund  
Joyce Pollack Montgomery '71, budget  
Nancy Neveloff Dubler '64, bylaws  
Patricia Hunter '69, careers  
Emily Gaylord '78, classes  
Elizabeth Westcott '71, club  
Anne Keating '51, council  
Helen M. McCann '40, fellowship  
Linda Krakower Greene '69, nominating  
Marilyn Umlas Wachtel '61, reunion  
Gwyneth MacKenzie Murphy '76, student affairs

### Directors at Large

Bette Kerr '62  
Mary Lou Chapuis Lempert '54  
Teresa I. Sivilli '81  
Francine Salzman Temko '43

### Office of Alumnae Affairs

Irma Socci Moore '50, director  
Eva Miodownik Oppenheim, associate director  
Yvonne S. Untch '50, alumnae records officer  
Telephone (212) 280-2005

BARNARD ALUMNAE, USPS #875-280

SPRING 1986, Vol. LXXV, No. 3

Published fall, winter, spring and summer  
Copyright 1986 by the Associate Alumnae of Barnard College, Milbank Hall, New York, NY 10027-6598

Second class postage paid at New York, New York and additional mailing offices.

Postmaster: Send change of address form to *Barnard Alumnae*, c/o Alumnae Office, Barnard College, 3009 Broadway, New York, NY 10027-6598.

# BARNARD

ALUMNAE MAGAZINE / SPRING 1986

## STAGES IN THE LIFE OF A BARNARD STUDENT

- 2 **Getting Here—The View from the Admissions Office**

by Jill Alcott

**Benchmarks of Quality**

by R. Christine Royer

- 4 **“The Dialectics of Morality: The Dilemma of Freedom and Choice”**

A Freshman Seminar in Review

by Marcia Welles

- 7 **Five Not-So-Easy Pieces—The Senior Thesis**

by Sarah Kennedy

- 8 **Building Architects at Barnard**

by Marcy G. Roth

## AROUND THE CAMPUS

- 12 **Jeanette Roosevelt Retires**

by Dawn Horwitz

- 13 **All About Translation**

by Sarah Kennedy

- 14 **CHILD CARE Through the Centuries**

by Alice Ribbink

- 17 **Green Grows New York**

Three Barnard women who help bring country and city together

- 19 **Call to Action on Aid to Education**

- 20 **The Answer Page**

- 21 **Events in the Arts**

- 23 **Seminars for Home Study**

- 24 **In Memoriam**

- 25 **Class Notes**

**Letters**—Inside Front Cover

COVER: *Spring on the Barnard Campus*, by Margaret Zweig Lee '75.

# Stages in the Life of a Barnard Student

## Getting Here — The View from the Admissions Office

by Jill Alcott

With each passing year, the undergraduate college admissions process grows more complex, enigmatic and anxiety-producing. Confused parents urge their children to sign up for SAT preparatory classes, participate in obscure high school activities, and develop a unique, impromptu talent. Hysterical students mail countless applications to every college whose name they have seen on a t-shirt. And colleges across the nation are becoming more and more competitive, devising sophisticated new ways to lure the young and aspiring to their campuses.

At Barnard, while the goal of attracting top quality young women who are independent thinkers has remained constant through the years, the admissions process is expanding, new facets are being developed, and the overall effort is growing stronger and more successful. And, contrary to popular impressions, there is a

method to the "madness."

From the College's point of view, the admissions process goes in cycles. The first phase, in the fall, involves recruitment, both on the road and on campus. Admissions associates and directors visit high schools of all sizes, public and private, secular and religious, in every region of the United States, in order to educate interested students about the benefits of a Barnard education. Individual itineraries are planned to fit into an overall scheme, with special trips added for special needs.

Admissions Associate Jeanne Van Ryzin '84 had an unusual visit in Washington State last year. Before the plans for her trip were complete, she received a letter from a student at Gig Harbor High School who asked some questions and indicated a sincere interest in applying to Barnard. After getting some facts about the course offerings at Gig Harbor and the percentage of graduates attending four-year colleges, Jeanne scheduled a stop there. Never before had a Barnard representative visited the school, and two interested students came to meet with her. The girl who had written the original letter proved to be "someone who was adventurous but needed encouragement, and I was able to provide just that," reports Jeanne. The student applied and came to Barnard in the spring during an Admissions Open House.

## Benchmarks of Quality

In choosing candidates for admission, Barnard looks for outstanding academic performers who also exhibit exceptional personal qualities. The decision to admit is the outcome of a close and careful evaluation both of objective, quantifiable data and of characteristics which elude statistical measurement but are exemplified in other ways. There is a high degree of overlap between the qualities of the students with superior academic ability and those of the students with outstanding personal traits. It is finally the combination of characteristics, the balance of the academic and the personal, which determines the overall quality of an entering class.

\* \* \*

As important as grades and other objective data in assessing a student's academic readiness for the experience of Barnard are such traits as

intellectual curiosity, intelligence, enthusiasm for learning, motivation, leadership, and character. We are interested in bright students with good minds who take delight in the learning process, who are self-directed, inquisitive, and willing to take intellectual risks, who have drive and persistence and are willing to work hard, to go beyond the required, who are imaginative and creative, and who enjoy writing, discussing, thinking, and interacting with their teachers.

\* \* \*

Although a student's academic ability is our primary consideration, we value involvement, achievement, and excellence in activities outside the classroom. A 1985 report, published by the Educational Testing Service and based on a seven-year study involving 25,000 applicants to nine colleges, emphasizes a finding of which most admissions people have long been aware, that is, that success in extracurricular activities is a strong predictor of success on all levels (academic, personal, social) in college.

In assessing the extracurricular and commu-

nity activities of our applicants, we look for *quality*, not *quantity*, of participation; we look for the *demonstration* of leadership; we look for the *accomplishments* resulting from special skills or talents. The students who have had in-depth involvement in athletics, musical groups, political or religious groups, community service and other organizations in high school are those most likely to be actively involved in the Barnard experience, sharing their interests and commitments with others on campus. They are also the ones most likely to become leaders and achievers in the same outstanding way that our alumnae long have.

Overall, we look for the breadth and depth of a student's intellectual and personal experiences and for evidence of her values, commitments, and aspirations. The result, insofar as we are successful in judging qualities which resist purely objective measure but which are among the components of excellence, is a class of interesting, bright, exceptional individuals.

R. Christine Royer  
Director of Admissions

Alaska was also on the Admissions Office circuit for the first time this year. Results, in terms of applicants, were immediate, including one student who asked to be considered for Early Decision.

Admissions Associate Sylvia Marquez '80, a native Texan, has played a major role in expanding our recruitment into the Southwest. Primarily interested in augmenting the Chicano enrollment, Sylvia points with pride to the fact that the number of Chicano applicants to Barnard has doubled since she joined the staff four years ago. "Whereas our sister schools have virtually given up in the Southwest, Barnard's reputation there is growing," she notes. In addition, Sylvia broke ground for Barnard at inner city schools where we were relatively unknown as recently as five years ago.

In 1985, the total number of secondary schools in Barnard's applicant pool was 852, 57.2 per cent of them public schools, and the total for 1986 is likely to be even larger. Admissions Director R. Christine Royer notes that "although most people are interested in the number of applications and in median SAT scores, one of the figures that is most gratifying to me is the number of schools sending applications to Barnard."

In 1979, when Chris Royer became Director, approximately 500 schools sent us at least one application. Since 1980, applications have come from 2,355 schools, which means that "Barnard's visibility has heightened and its name is better known throughout the country." This increase reflects the director's emphasis on expanding the scope of our recruiting, including such programs as luncheons for high school counselors in areas where Barnard is not yet a familiar name. The goal is to keep the numbers rising every year.

The recruiting season "out in the field" is long and intense. The Admissions staff agree that it is crucial during this time to remember the purpose of recruiting. "I believe strongly in the value of education as a vehicle through which young people can explore their untapped potential," says Felicia Y. Thomas, one of the six Associates on the Barnard team. "When students who have hidden talents have the opportunity to take a challenge here...when they come...I'm psyched!" Elizabeth O'Shea, Associate Director of Admissions, feels that "making the students aware that they have many choices for college, especially a choice like Barnard" is most exciting. Raising the consciousness of young women from

## Extending Barnard's Outreach

The field work of the Barnard Admissions Staff is supported by a network of selected alumnae who serve as Barnard Area Representatives — BARs — across the country and abroad. They maintain contact with nearby schools, attend college fairs, respond to inquiries about Barnard year-round, and interview interested students who are not able to visit the campus. Training sessions for BARs are held every fall as part of Alumnae Council, and materials are sent to them regularly to keep them up-to-date with the curriculum and other aspects of Barnard life. The BAR network was strengthened and increased this year, so that it now numbers over 150 alumnae.

varied economic and family backgrounds regarding their educational options — that is a major motivating factor behind the Admissions effort.

Meanwhile, back home in 111 Milbank, other staff members are busy interviewing prospective students — often as many as fifteen a day. Members of the Barnard Blue Key Society, a group of undergraduates dedicated to enhancement of the admissions process, serve as guides on campus tours for visiting students and their parents. This aspect of the recruiting process complements the traveling component and has equal import and effect on the final composition and size of the freshman applicant pool.

Although interviews and campus visits are not mandatory, the Admissions Office considers them a non-quantifiable "plus" on an application and recommends them to interested students. If a trip to New York is not possible, a young woman can learn about Barnard, and help Barnard learn about her, by meeting with a Barnard Area Representative (BAR) in her community (see box).

Every December, as the fall semester is ending on campus and high school seniors everywhere are writing to the colleges of their choice, the Admissions staff return from their travels and re-assemble at the office. Now they must begin the critical and demanding task of coding applications, so that the various types of information can be compared and, eventually, entered in the computer for analysis. They must also begin to read and evaluate, taking the "Early Decision" applications first, then the

*continued on page 16*

Jill Alcott '85 is completing her first year as an Admissions Associate.



Jill Alcott '85 (l.) and Associate Director Liz Bothamley '72 (r.) talk with prospective students at an Admissions "Open House."

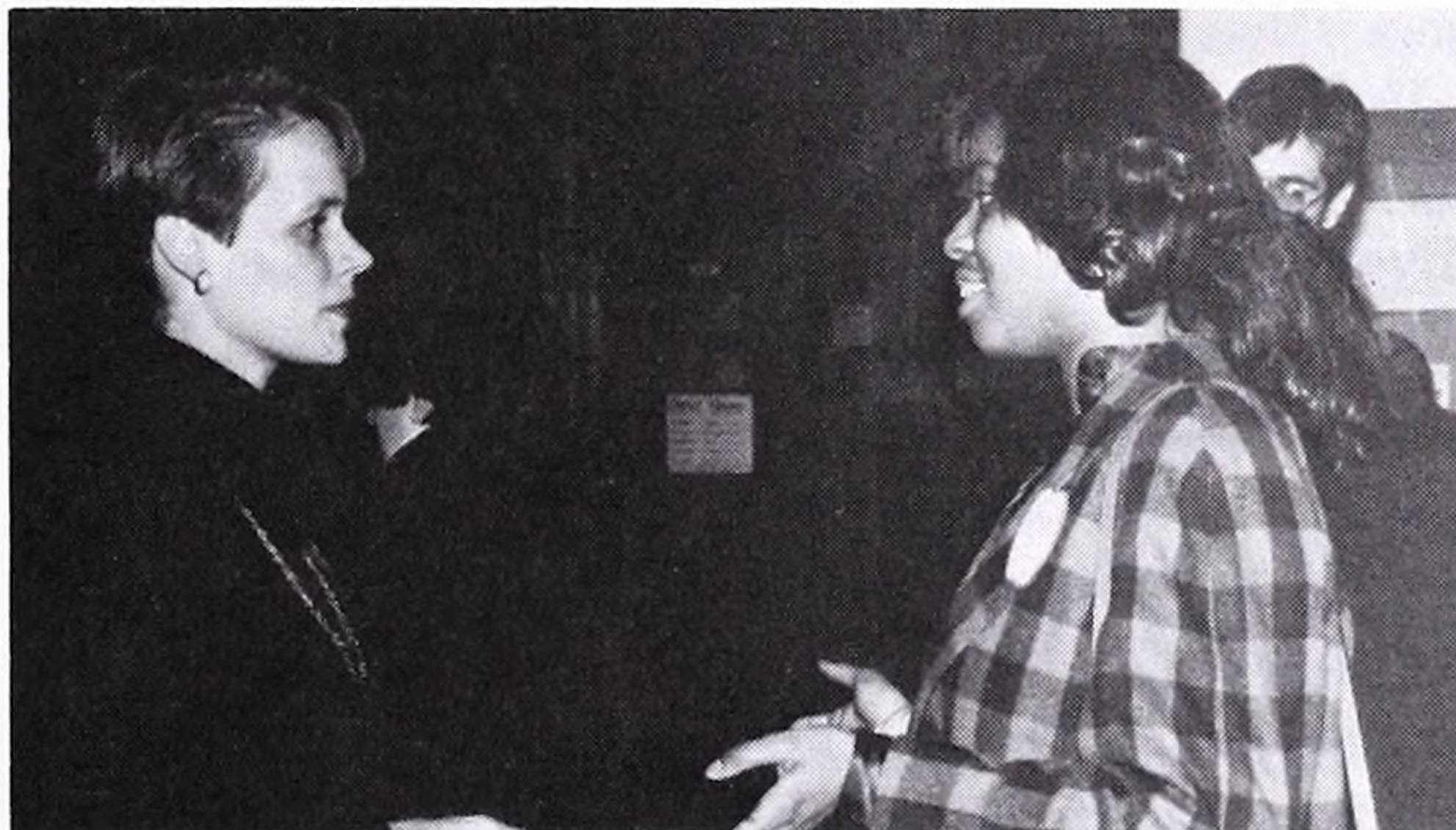

Karen Jolkovski

# “The Dialectics of Morality: The Dilemma of Freedom and Choice”

A Freshman Seminar in review

by Marcia Welles

In accordance with its title, “The Dialectics of Morality,” the method of our course was to “juxtapose opposed or contradictory ideas and usually seek to resolve their conflict.” The students and I together pondered the issues as they arose in the texts we studied. Each work was like a diamond, which we turned in the light of critical contemplation to admire its rich and diverse facets. At the end of our endeavor we had not learned about the particular composition or structure of each gem; we had learned, however, to discern differences and appreciate subtleties of color and brilliance which we had not seen before.”

In the opening passage of *A Tale of Two Cities*, Charles Dickens describes the state of the world on the eve of the French Revolution in phrases which are familiar to us all: “It was the best of times, it was the worst of times, it was the age of wisdom, it was the age of foolishness . . .” and so on. As he continues, he seems to be describing a world in which there are only two nations of any importance, France and England. And we, *mutatis mutandis*, can consider this an apt analysis of our own period.

What we cannot echo, however, is Dickens’ further statement that “in both countries it was clearer than crystal to the lords of the State preserves of loaves and fishes, that things in general were settled forever.” On the contrary, it seems to be permanence, not change, that shocks us. In 1633, Galileo was forced to recant his findings about the movement of the earth; in 1986, the stable universe postulated by the authority of the Bible and the learning of the ancients (geocentric, theocentric, anthropocentric) is not only an example of benighted thought; it is literally inconceivable to us. Our ability to accept and absorb change is proven — this is not a problem. Now we have a different problem, best stated in the tale of the airplane pilot who told his passengers he had two pieces of news: “the bad news is that we are lost; the good news is that we are making excellent time.”

Does this not illustrate our contemporary attitude — a sense of going nowhere, fast? Camus chose the myth of Sisyphus, condemned to roll uphill a rock that would only roll down again, to exemplify the purposelessness of life. Our popular culture — “Help” sang the Beatles, “I need somebody’s help” — captures the forlornness of youth, many of whom seek as a means of escape the avenue of “having” (as opposed to that of “being”) — “I’m a material girl,” admits Madonna, no doubt gloating at the discomfiture of parents. Yet any formulation of the question of the “meaning of life” seems pompous and our uneasiness prompts us to make jokes about it:

“Life is a fountain,” says the sage; “What!” shrieks the uncomprehending seeker after truth. “You mean it’s not a fountain?” says the wise man.

When we discuss the “dialectics of morality,” the allusion to ethics is not to a system of defining right and wrong, to that form of morality which David Hume (*Inquiry into Morals*) characterized by the slippage from “is” (descriptive) to “ought” (prescriptive). It relates rather to ethics as “character or ideals of characters, which in turn determines moral values.” Our “being,” or “character,” manifests itself most clearly and intensely in moments of choice, for in the process of making decisions (non-trivial ones, I mean, not which flavor of ice cream we prefer on a hot afternoon) we define who we are. Some possibilities we include; others we reject. These decisions many times involve our evaluation of the effect of a choice not only on ourselves, but on others. These choices shape our lives, and in so shaping our life we give it meaning.

How do we learn about choices and the values they entail, about seen and unforeseen consequences? How do we learn to weigh alternatives? Science can offer us facts, objective truths; so, too, the social sciences, which contrast and compare the value systems in different societies. It is, however, the humanities that have traditionally been preoccupied with values as such. They can accommodate the multiplicity and diversity inherent in complex moral issues without the need for logical precision or systematic dogma. Not bound by the awesome imperative to “Truth,” the humanities can withstand the onslaught of paradox and absurdity; less concerned with solutions than with processes, the humanities can reveal the pain or anger, tenderness or love that accompany dilemmas of conscience. It is no accident that Freud, as he forged his new “science” of the non-rational aspects of persons and delved into the mysteries of human motivation, often alluded to literature and art in support of his findings.

Ethical questions concern the relationship between the self and the other. We live separated from the other; contact can be made through touch, but much more frequently through language and discourse — not “idle chatter” or the rhetoric of propaganda or the neutralized, mediocre language of the media, but language that expresses our individuality. Because the instrument of literature is language, literature provides us with the most direct insight possible (beyond our own experience) to the conflict of values inherent in moral dilemmas. As readers respond to the issues and characters in great works of literature, they gain insight into unexplored dimensions of themselves. Strong reactions, negative or positive, provoke us into a consideration of our own system of values. Sometimes we are startled by what we discover.

With the exception of three works (Plato’s *Apology*, Robert Bolt’s play *A Man For All Seasons*, and Elie Wiesel’s *Night*), the texts we read in “The Dialectics of Morality” are

all works of fiction. Is it not ironic that in these works, which by definition are not true, we seek some kind of truth and understanding. The authors do not offer us logical proofs. They make no statement about their moral views. How then, do they convey to us their moral vision, and how do they control our response?

Poetic language proceeds by indirection, by connotation rather than denotation, manipulating our emotional response by means of association, rather than by bold-faced assertion. The subliminal persuasion facilitated by the rhetoric of fiction is a powerful weapon: the reader, not armed in advance for the onslaught of political weapons or the tirades of advertisements, easily falls prey to the insinuations of a clever tongue and responds according to design. In Shakespeare's *Measure for Measure*, Duke Vincentio decides to leave the government in the capable hands of Lord Angelo, described as "a man of stricture and firm abstinence." Further clues about his character are given to us in a cluster of metaphors, creating an impression of coldness and inhumanity. As post-Freudian readers, we are prepared for the perverse manifestation of these repressed impulses in the attempted abusive seduction of the chaste Isabella. Shakespeare's paradoxical message is that "Some rise by sin, and some by virtue fall." Whether stated in psychological language as the ideal of a "balanced" personality, or in the language of classical Aristotelian ethics as the ideal of the "golden mean," the reader understands that the assumption of extreme positions (even in defense of moral uprightness) can have tragic consequences.

**"Less concerned with solutions than with processes, the humanities can reveal the pain or anger, tenderness or love that accompany dilemmas of conscience."**

Metaphors provide us with insight in another work, Cervantes' short story "The Tale of Foolish Curiosity." The newly married Anselmo wishes to test the virtue of his wife and tries to persuade his dearest friend to help him in this endeavor: "I cannot be sure of the truth except by testing her by an ordeal which shall prove the purity of her virtue, as fire shows the purity of gold. . ." Anselmo's choice of similes affords us an insight into the reason why his "test" is so sinful, comparing his wife to a metal, subjecting her to a pseudo-scientific experiment. His argument, which to him alone seems logical and convincing, reveals his moral pathology; his illness will eventually result in the death of all three characters.

Moral insights can also be conveyed by more subtle means, such as modes of address that are indicators of a

cultural context. In Nadine Gordimer's short story, "Blinder," the colored maid is named Rose; her mistress is identified throughout as "the lady of the house." The issue is not personal, for the lady is kind; it is social. The hierarchical form of address betrays the infrastructure of racial division and power politics in South Africa.

Let us look at an American novel, Kate Chopin's *The Awakening*, the story of Edna, a dissatisfied and unfaithful wife and mother who eventually commits suicide. That the book scandalized St. Louis society when it was published in 1899 does not surprise us, but judgments by recent critics—male—merit our attention. They have defended the aggrieved husband who tries to "understand" his wife; one commentator writes that she displays a "discontent . . . for no apparent reason"; another that there is "no sound reason for the discontent she feels."

In the first scene in this novel between husband and wife, the family is at a summer resort and Edna has bathed in the ocean. Leonce glances at his wife as she walks along the beach. "You are burnt beyond recognition," he added, looking at his wife as one looks at a valuable piece of personal property which has suffered some damage." The author is telling us why Edna is unhappy. Her husband's first words convey a reprimand, as though she were a child; his first look conveys domination, property ownership, as though she were a "thing." But she is neither a child nor a thing, but a woman.

The critics in this case have betrayed moral biases that have dulled their critical faculties. Implicit in their comments is the supposition that a well-provided-for married woman with children and a "good" husband should be happy—but a cage, even if gilded, remains a cage. In a few words, Kate Chopin has revealed the imbalance of power of the societal subtext—here the characters are Edna and "the man of the house."

We can appreciate the extraordinary concision and effectiveness of these authors, who have managed in these "micro-texts" to convey moral meaning. Even more noteworthy, a 17th-century Spanish author, a late 19th-century American novelist, and a contemporary South African writer share a moral vision which applies equally well to their varied contexts. The underlying premise is that moral behavior must be conditioned by respect for the other person.

Kant's formulation (*Foundations on the Metaphysics of Morals*) was that everyone should be treated as an "end-in-himself" (herself, we will add) and not merely as a means; that a distinction must be made between that which has a price and that which is literally "price-less" (the dignity of a human being). Failure to treat the other as a valuable and independent person—by defining the other as a unit of labor (valued only for strength or skill) or a unit of exchange (a female, valued for her beauty and fertility)—leads to personal and societal tragedy.

The works mentioned above permitted us insight into what we might consider the foundation of ethical behavior: our relationship of moral responsiveness to others. But in this world of pluralistic values and endless



Professor Marcia (Andersen) Welles '65 is a member of the Barnard Spanish Department. This article is based upon a lecture presented to members of the Barnard College Club of New York.

complications, situations arise constantly in which equally valid but competing claims are made upon us, and a judgment must be made concerning alternatives. This can lead to a paradoxical conclusion, as in Ibsen's *The*

**“Powerful ethical conflicts can occur only where the alternatives are *both* compelling and share qualities of ‘rightness’: pitting absolute evil against absolute good may captivate our emotions, but not our intellect.”**

*Wild Duck*: Gregers, an earnest believer in the pursuit of truth, by uncovering the deceit of the lives around him causes the needless sacrifice of an innocent girl. He has failed to distinguish between the need not to lie and the need to promote the truth, in this case achieved without responsible forethought of consequences. Exceptionless moral principles on the order of Kant's “categorical imperative” may be perfect, but then the perfect has been said to be antithetical to the good!

Powerful ethical conflicts can occur only in instances where the alternatives are both compelling and share qualities of “rightness”: pitting absolute evil against absolute good may captivate our emotions, but not our intellect. There is, after all, no real choice to be made between the Powers of Lightness (Luke Skywalker and Princess Leia) and the Powers of Darkness (Darth Vader). Hegel considered *Antigone* the “supreme and absolute example of tragedy” because the collision represented in the play is between powers of equally awesome weight. “Creon,” writes Hegel, “is not a tyrant, but really a moral power; Creon is not in the wrong; he maintains that the law of the State . . . is to be held in respect, and that punishment follows the infraction of the law.” In the end his pride destroys him.

We learn that law is not synonymous with morality — or at least that human laws must contend with divine law and the strength of individual conscience to proclaim its Truth. As Antigone defies the State for the sake of the nether gods, so Socrates rejects the findings of the Athenian tribunal, recognizing his obligation to his own “daemon,” and Sir Thomas More, whom Bolt calls the “English Socrates,” remains faithful unto death to his convictions.

*Antigone* was produced in 441 B.C.; Socrates died in 399 B.C.; Thomas More was decapitated in 1535. Both fictional and historical, these ethical heroes belong to yesteryear. In his comparison of classical and modern

drama, Hegel noted that “modern characters also differ in the nature of the constancy or their spiritual vacillation and distraction . . . Although the tragic action must depend on colliding factors, yet where we find a division in one and the same individual, such concurrence is always attended with precarious consequences.”

Even before the “Freudian revolution” with its postulation of irrational, unconscious forces as motivating factors in character formation and behavior, confidence in man's rational faculty had begun to fracture. The Reign of Terror shattered the optimism of the Enlightenment. In “The Marquise of O,” the 18th-century German author Kleist confronted the unknown forces in human nature, playing out a series of paradoxes whereby a lady of “unblemished reputation” gives birth to an illegitimate child, impregnated she knows not how. The rapist is none other than he who saved her from rape by others, an aristocratic and upright gentleman, not some degenerate form of “scum.”

Such a devastating, incomprehensible rupture between character and action is central to Melville's “Billy Budd.” The innocent, simple, good-natured, handsome sailor, Billy Budd, kills (albeit unintentionally) the depraved and conniving master-at-arms, Claggart. Billy, who is good, does evil; Claggart, who is evil, is his victim. Captain Vere knows Billy is morally innocent but sentences him to death. As readers we are fortunate — we are not called upon to pass judgment. We are allowed the luxury of rumination, of accepting the virtual “undecidability” in some cases of “right” and “wrong.”

**“As readers respond to the issues and characters in great works of literature, they gain insight into unexplored dimensions of themselves.”**

Ethics in the courtroom is another matter, as Plato explains in *The Laws*: “When a poet takes his seat on the tripod of the Muse, he cannot control his thoughts . . . When he represents men with contrasting characters he is often obliged to contradict himself, and he doesn't know which of the opposing speeches contains the truth. But for the legislator, this is impossible: he must not let his laws say two different things on the same subject.”

Perhaps literature achieves a greater “truth” in ethical issues because it can acknowledge that, as Melville writes, “Truth uncompromisingly told will always have its ragged edges.” Discussion of these “ragged edges” of characters and plot allows us to understand the difficulty and responsibility of moral choices in this modern pluralistic age. The quest for an ethical life is undeniably challenging and creative, an exciting opportunity for a freshman seminar.



# Five Not-So-Easy Pieces — The Senior Thesis

by Sarah Kennedy '86

After four years of hard work, graduating seniors find that their last few months at Barnard are the busiest time of all. They are looking for jobs, fulfilling the science requirements that they left until last, sending off applications to graduate schools, ordering caps and gowns and worrying about tickets for graduation—and they are finishing their theses. While it is something of a burden, the senior thesis is also an opportunity, to think and act independently, to take initiative, to combine the rough fragments of one's education into a finished product.

English is still the major chosen by the largest number of Barnard students, but there seems to be no end to the supply of possible research topics. Suzanne Miller "wanted to write about a female author who expressed a distinctly female voice in the epic genre," and for this purpose H.D. (Hilda Doolittle) was a natural choice. Having chosen a genre dominated by men, H.D. had written *Helen in Troy*, about the Trojan War. In contrast to *The Iliad*, however, the Helen in her version has an active voice, rather than being only a subject for the men to describe.

"I expected a lot from H.D.," recalls Suzanne. "I wanted to discover a female literary tradition which refused all patriarchal influence." At first she was disappointed in the text, since it was revolutionary only in form. She felt that the author had undermined her own goals by allowing Achilles to define Helen, and ultimately appropriate her voice. And while Helen is the heroine, her responses are directed to the gods of Greek mythology, not the goddesses.

After a few months of study, Suzanne began to judge the author less harshly: "Women's literature can't be regarded as 'black' or 'white'; rather it exists within a gray zone. It represents a combination of feminine and masculine consciousness. No female canon of muses can stand up to the patriarchal state that surrounds us."

Suzanne felt personally connected to this paper, believing that it would help her solve her own problems with voice. In her view, it is only recently that women have begun to assert their right to language, and so the relationship is often confusing. She believes that works such as H.D.'s can point us in the right direction.

The New York real estate market was of interest to economics major Robyn Binstein, particularly the rapid pace of conversion of rental apartments to condominiums and co-ops. She knew she wanted to present an overall picture of this trend in her senior thesis, and an internship at Time Equities made it possible for her to analyze the process as it occurred in specific buildings. She studied five co-op conversions accomplished by the company in the past year and examined the reasons for the various levels of their success. Three of the buildings in her sample are on the up-and-coming Upper West Side, one is in Brooklyn, and one in the Bronx, so she was able to include comparisons between conversions in Manhattan and in the "outer boroughs."

Among the factors which had to be considered in the course of Robyn's study were building location and condition, tenant characteristics such as age and income, and costs of rent vs. carrying costs of converted apartments. Her analysis included market forces affecting both investors (sellers) and purchasers. In addition to the opportunity to apply economic theory to the marketplace "here and now," the project has given Robyn a solid foundation for a career in residential real estate.

Articles about the Statue of Liberty have appeared everywhere this year, including the *Wall Street Journal*, and it was there that Kerry Fitzsimmons found the inspiration for her senior thesis. An art history major, Kerry has been learning and writing about the techniques used by a group of French artisans on the restoration project — the same techniques as those used in the original construction one hundred years ago.

Kerry first visited Liberty Island in December and climbed the scaffolding to look at the newly installed gold torch. In the temporary workshops on the island she watched as skilled workmen hammered the copper sheeting into shape, using a series of molds of varied degrees of detail.

In addition to her on-site research into the reconstruction of the Statue, Kerry has considered its origins and symbolic importance, with the aid of courses such as "The European Image of America" and "Ethnicity in America." She wonders "how future generations will perceive the Statue after the super-marketing of her image, selling everything from Stroh's beer to Avon lipstick."

Most psychology majors take the Graduate Record Examination in order to demonstrate their qualification for a degree, but some choose to do a research project instead. Members of this group (six this year) meet regularly to discuss and direct their research with the help of one another and a faculty adviser. One of these students is Miriam Given, who made a study of implicit memory — that is, that aspect of memory dealing with information which we have learned unconsciously.

The study of implicit memory is seen as potentially valuable in the treatment of amnesia, whose victims per-

*continued on page 16*



Ava Rose

Karen Jolkovski

Hope Dana '85, Library,  
Addition to a Cultural Center.

# Building Architects at Barnard

by Marcy G. Roth

**“Just what kind of education produces the best architect?” A pre-professional program within the liberal arts rests on a delicate balance of technical and humanistic studies.**

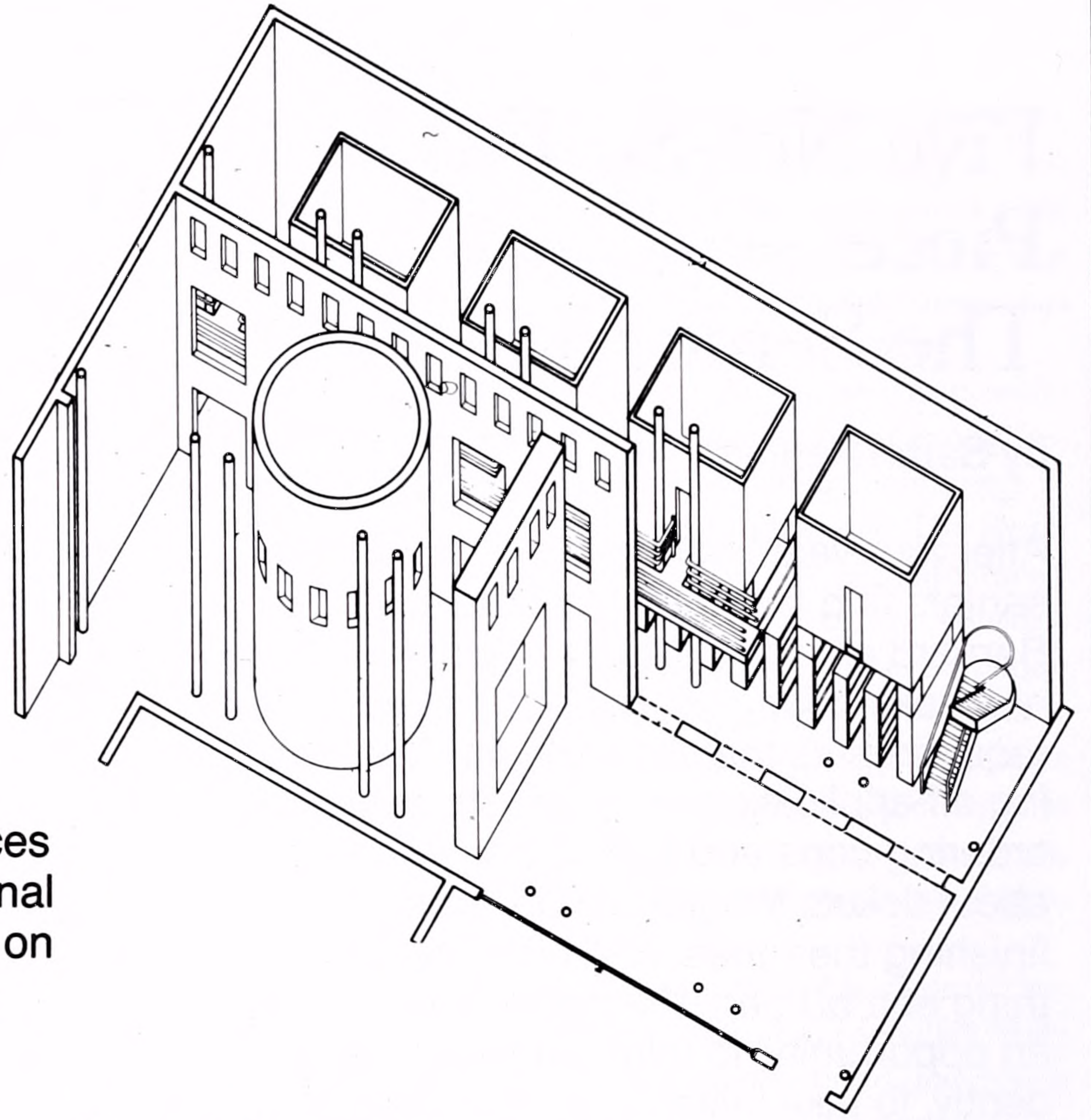

Colleges change with the times. When I went to Barnard in the late '60s and early '70s, students demanded and got courses on Black American history and Women's Studies. The social consciousness of those days is less prominent now; the financial burden of a fine college education has resulted in a professional pragmatism among students which has in turn produced new courses of study. In 1986 a Barnard student can enroll in three modules of quantitative reasoning, take a minor in "Health and Society," or major in Computer Science. The uneasy alliance of the old liberal arts and the new vocationalism has found a natural home in one of Barnard's newest programs, the Architecture major.

Discussion of a Barnard architecture major began about 1979, when Barnard students were already taking Columbia's cross-listed design studios. James Stewart Polshek, dean of Columbia's Graduate School of Architecture and Planning, approached Dean of the Faculty Charles Olton with the suggestion of a separate program for Barnard students. As Dean Olton recalls, Dean Polshek hoped that Barnard would provide a broad, liberal arts emphasis to balance the heavily pre-professional curriculum of Columbia College.

Barnard's fledgling architecture program retained the shared courses with Columbia but made important changes. The number of design studios was limited to two semesters, usually taken during the junior year, while Columbia still required a Senior Studio. A cluster of three courses in a related field—art history, political science, geography, history, philosophy, environmental conservation and management, psychology, sociology, urban studies, anthropology, economics, or studio art—formed the basis of the student's extra-architectural studies.

Requirements also included five lecture courses on architectural history selected from a list of eight offered

by the art history and architecture departments of both schools, and two seminars which were analytical complements to extensive design work. Students intending to continue in graduate studies were advised to take physics and calculus. On top of the general courses required for a Barnard degree, it made a demanding program.

Probably the most significant aspect of Barnard's separate program was the assignment of a faculty member to direct it, ensuring a close advisory relationship for the approximately 25 juniors and seniors taking the major in any one year. Columbia's program was and still is "coordinated" by a member of the graduate school faculty; College students must stand in line after graduates to get individual guidance from professors.

It was Barnard's traditional interest in the individual, and its commitment to educating women, that attracted Susana Torre to the directorship of the program in 1982. An internationally renowned architect who had taught extensively in the United States and abroad, Prof. Torre has a clear view of how undergraduates should learn about architecture. "First, you must teach the students to love architecture, very passionately, but at the same time to realize that the fulfillment of that love cannot be achieved without rigorous discipline and an understanding of what I like to call architecture's own point of view, that is to say, the body of ideas and theory that informs the practice of design itself."

The Junior Design Studio, which Prof. Torre developed and, with other faculty members, continues to teach, is the heart of the program. Lectures and discussion complement an intensive design agenda of drawing and modelmaking. Among the projects assigned in last year's studio were an addition to a library, a conference area on one floor of a townhouse, and a juncture of park and city which included landscape architecture. For most of the students, it is the highlight of their undergraduate



Simon Benepe  
Marcy Roth '73 is a freelance writer. She is working on a documentary film about New York's South Street Seaport.

experience. "When you're just starting out, you hear the upperclassmen complaining, and you go crazy," recalls Petra Schwartz '86. "You're scared, thinking 'I can't do this.' So you go in, head first, and while you're doing it, it's o.k. You're working very hard, but you know you can do it. And then you look back and say, how did I do this?" Ms. Schwartz not only survived Junior Studio but won last year's Marcia Mead Award for the best design by a Barnard or Columbia student.

The rigors of the Junior Studio are a good taste of what graduate school will be like, and some students become aware that the field is not for them. However, so many students expressed a strong desire for more design opportunities that a Senior Studio was added to the program this past year. Ironically, the course appeared at Barnard after it was dropped by Columbia in a move toward liberalization of their own undergraduate major.

At this point in the program's brief history, the faculty is determined to preserve a liberal arts emphasis in the face of the students' fears that the major isn't technical enough to provide adequate preparation for graduate school. Although the Senior Studio is now offered, two popular technical courses, "Fundamentals of Architecture" and "Advanced Graphics," have been dropped. "Fundamentals," which Prof. Torre taught, was a complex and intensive introduction to the field, normally taken in the sophomore year, comprised of lectures, discussions, and drawing assignments. As a preparation for the Junior Studio, the students felt it had been indispensable. The course was dropped at the end of Prof. Torre's tenure as director, and has been partly absorbed into the Junior Studio. Prof. Torre described the "Advanced Graphics" course for seniors as remedial, adding that such a course can be taken at any one of several technical schools in New York.

According to Prof. Torre, both courses were removed to make way for further exploration of the humanities. "We had to make certain choices, and we decided that the structure of the major really had to allow the students a full range of educational experience in four years of college. We felt they would inevitably be exposed to the design component elsewhere, and that at this time in

their lives they should take more philosophy or poetry or history courses."

Just what kind of education produces the best architect? Prof. Donna Robertson, who currently directs the program and who studied English literature at Stanford before taking an architecture degree at the University of Virginia, believes there is a trend toward intellectualism in architecture. In her view, a strong liberal arts education is the most valuable preparation for budding architects. "We'd like them to understand architecture as a discipline and as a manner of approaching knowledge about the world at large. It is important to understand the history of those built artifacts that various cultures have left behind. It's a way of understanding the relationship between architecture and the historical experience that created it." She advises students who are anxious to take more drawing and design courses to be patient. "That's all you do in graduate school. I tell them, if there's anything you ever thought you were interested in finding out more about, do it now, because this is your last chance."

Graduates of Barnard's young program generally agree that the best preparation for a thoughtful, responsible architect is graduate study founded on four years of humanistic studies. "It doesn't matter how well you draw if your ideas aren't rich," said Hope Dana '85, who is completing her first year of graduate study at Columbia. "There are people in graduate school who can draw well but their ideas aren't good." Although an accomplished draftsman, Ms. Dana is most grateful to Barnard for her knowledge of history and architectural theory. "You can design better if you have a broader knowledge," she said, adding that there are a doctor and a lawyer in her class at Columbia.

Molly Reid, also a 1985 graduate, took her major in philosophy and minored in architecture. She is working for a small firm in Manhattan and will apply to graduate school next year. Her goal at Barnard was to get a solid liberal arts education, although she was fairly certain she would go on to advanced study in architecture. "It's probably important in any discipline, but especially so in architecture because you can get so wrapped up in the

Petra Schwartz '86, *Design for a Writer's Room*. For William Gass, novelist and philosopher, who required the space for his specific needs in research and writing.

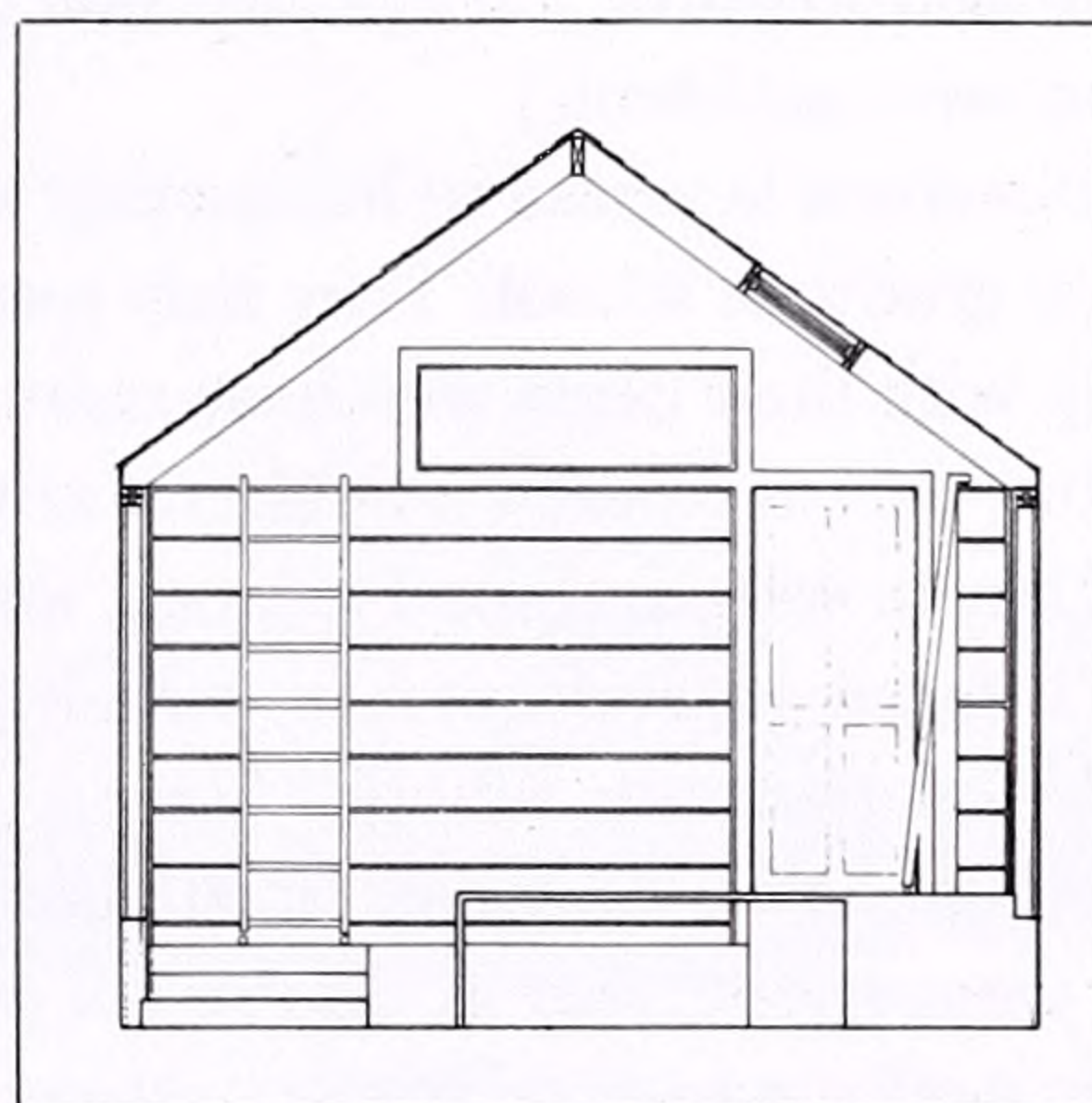
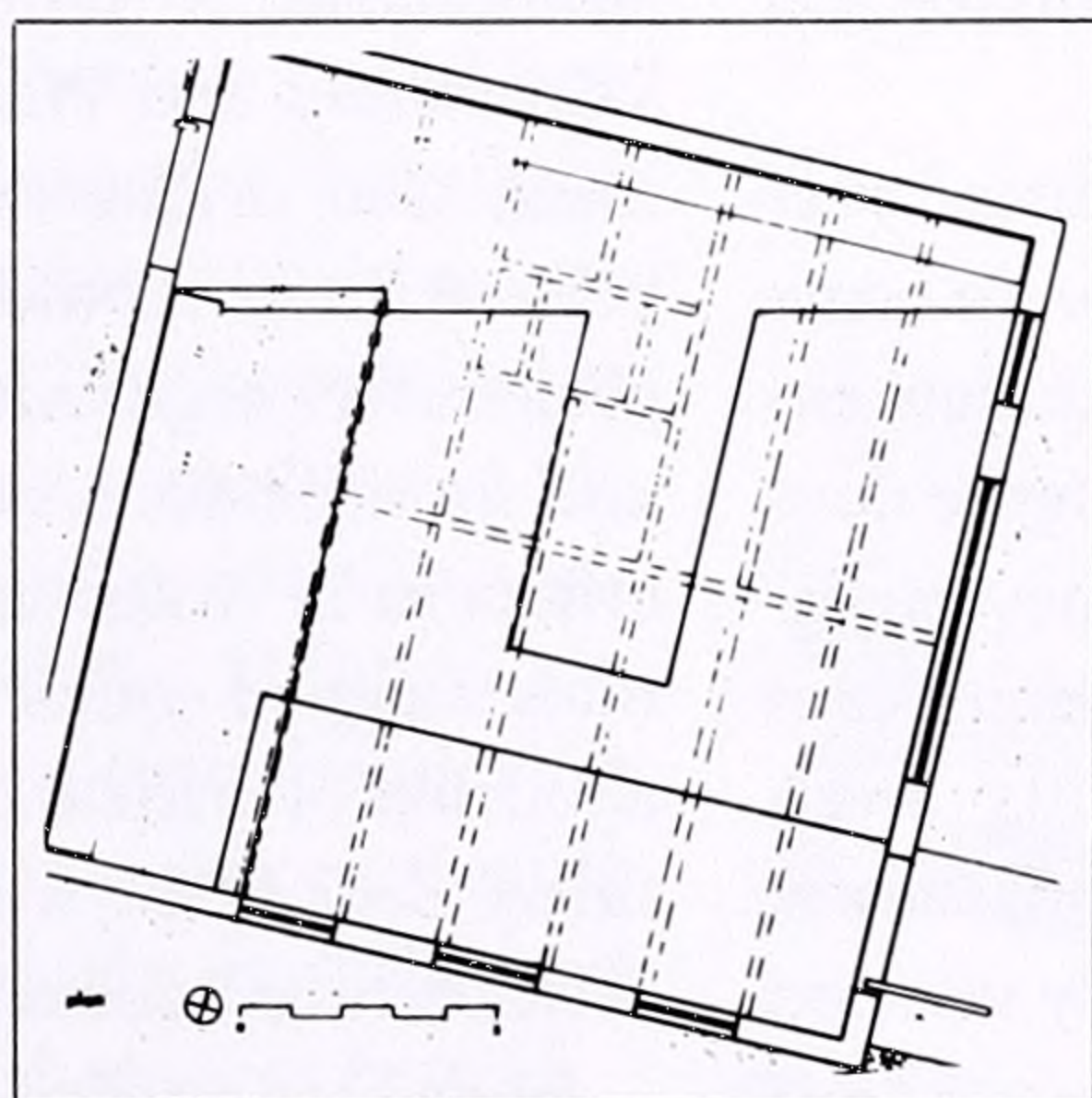
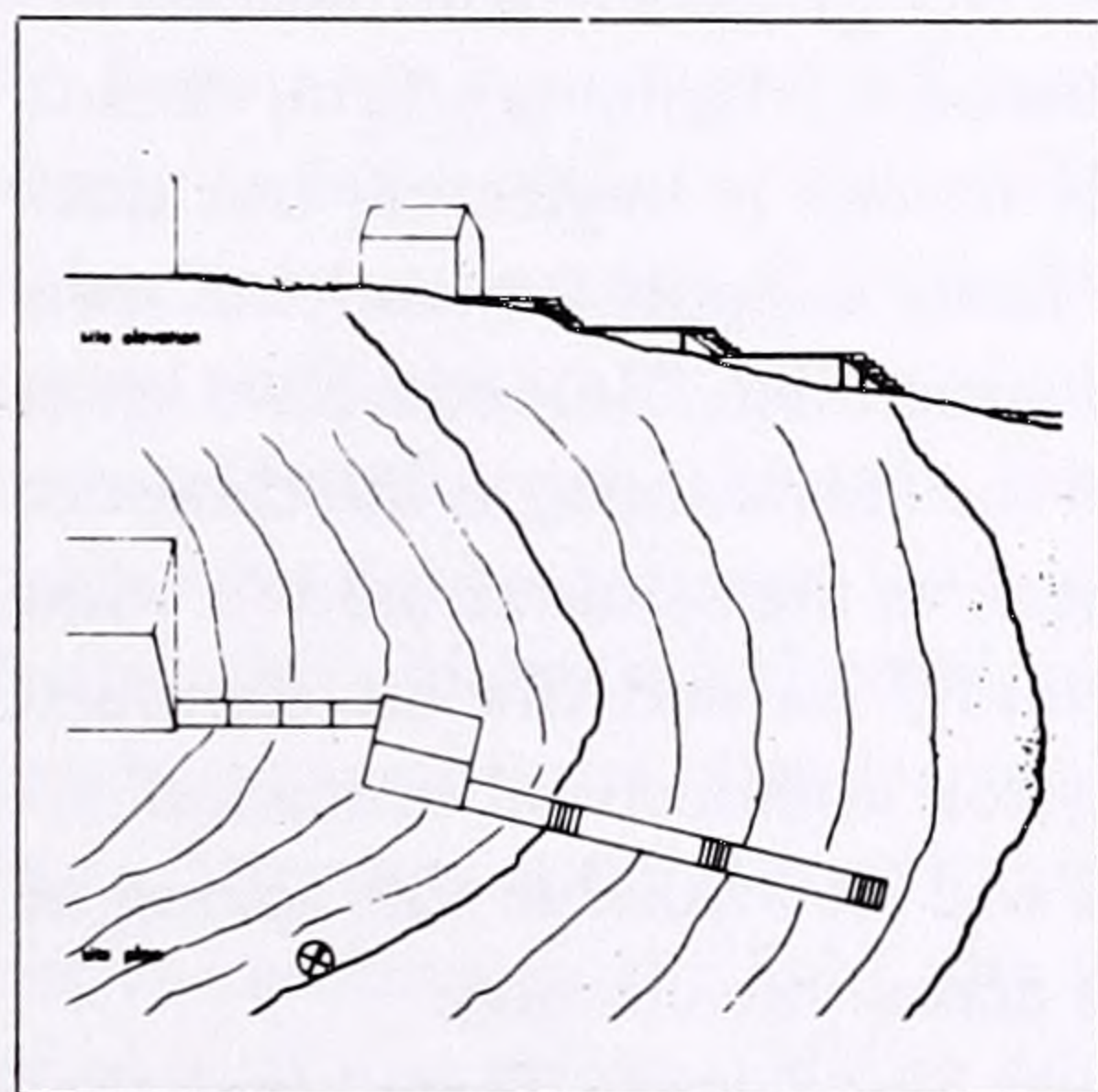

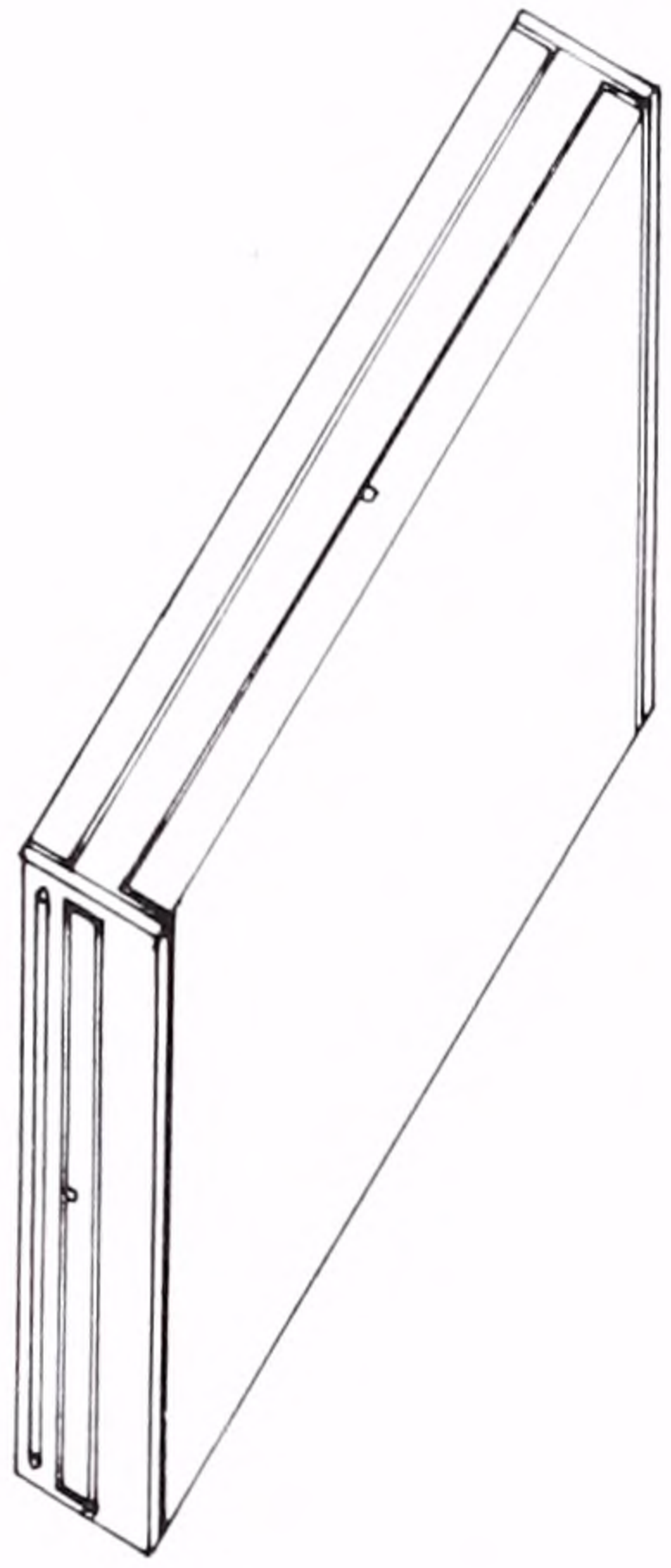

Lara Koulajian '87, *A Portable Writing Tablet*. The project called for a lightweight, durable device to provide surface and storage for pens, paper, pencils, etc.

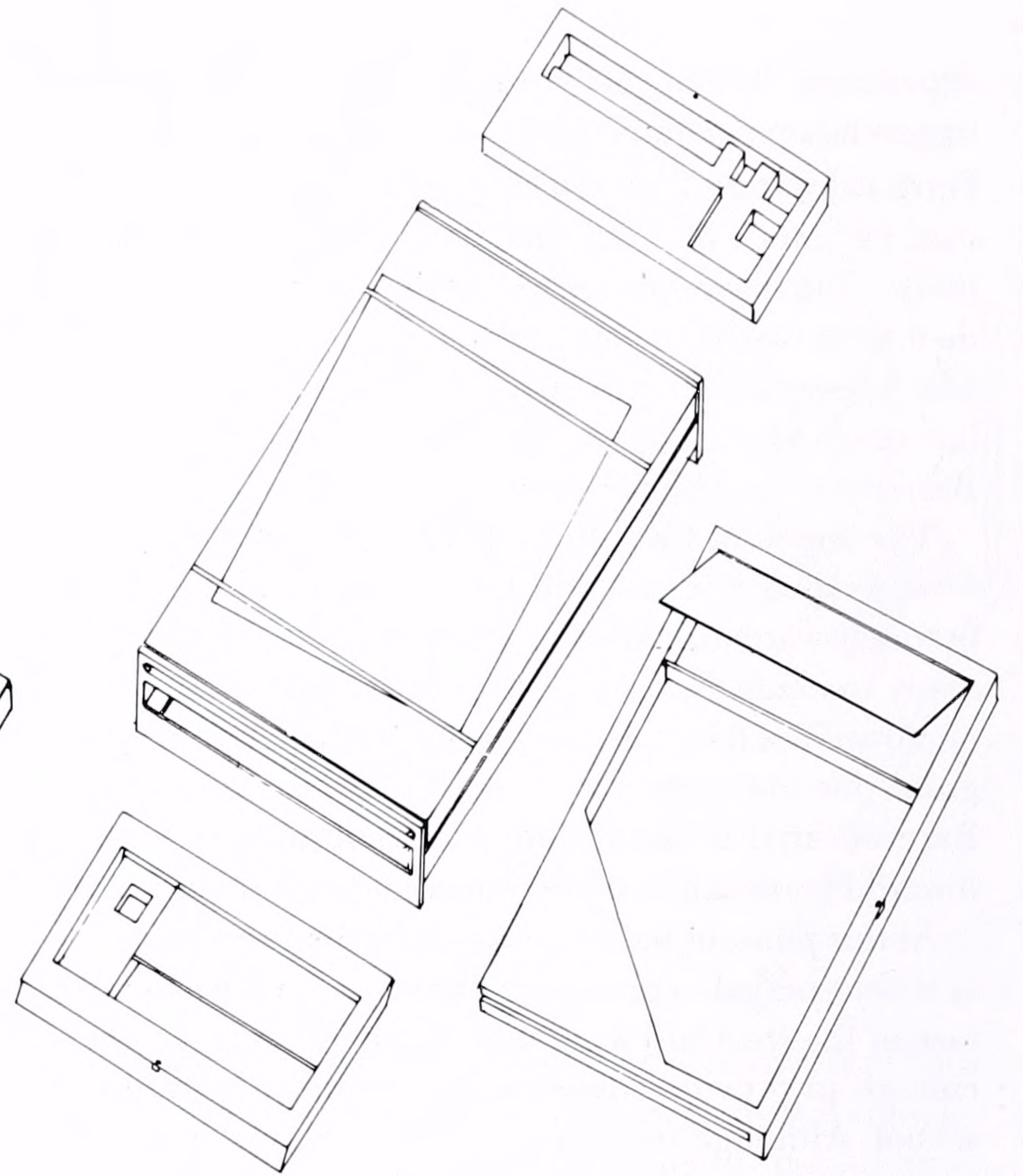
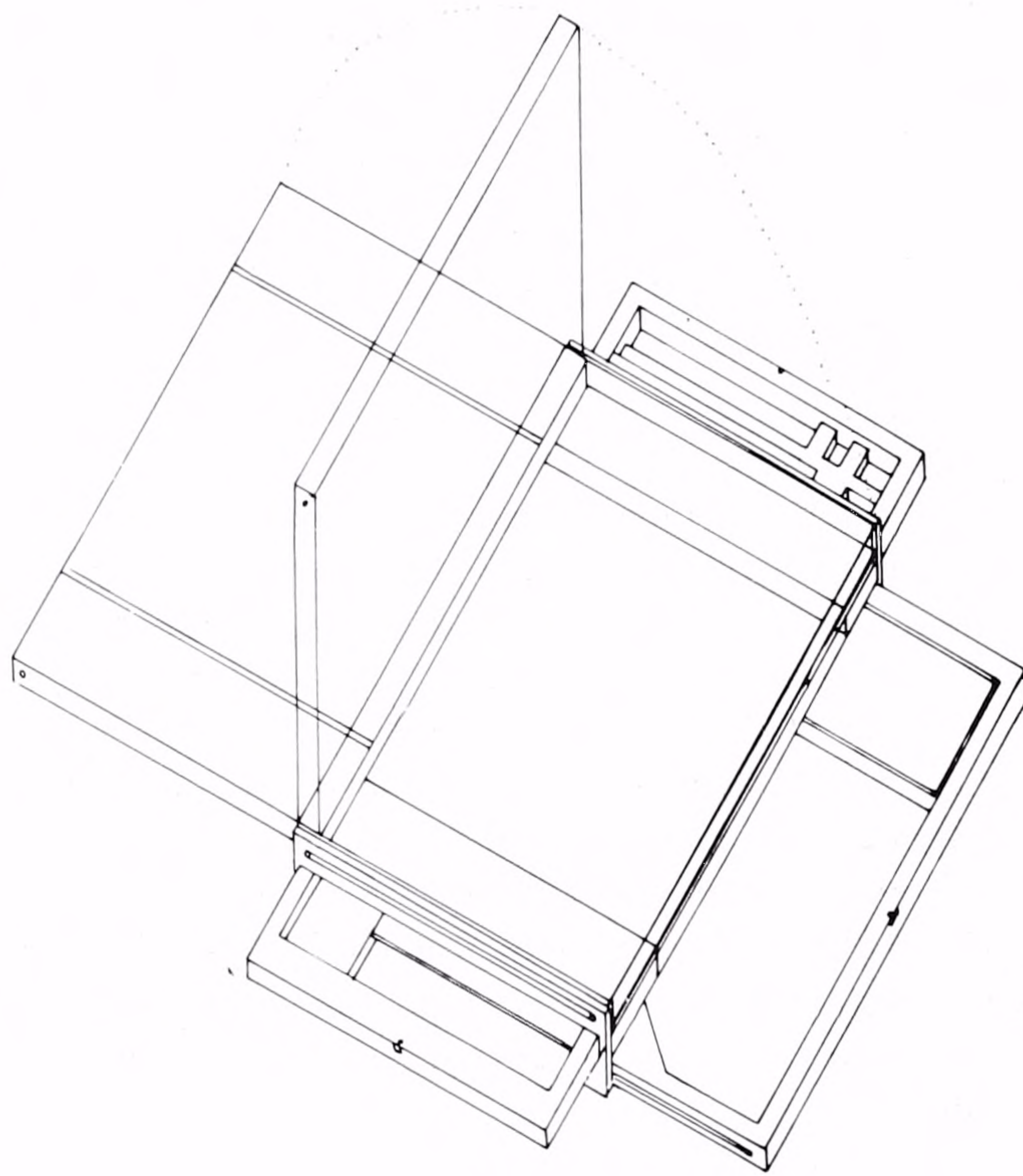

wrong things so quickly, like concentrating on details. Because it's an art, the more you bring to it, the broader understanding you have."

The program also offers courses which give students some exposure to career opportunities outside of architectural practice. This is particularly the case with two seminars, "Landscape Architecture," taught by art historian Deborah Nevins, and the "Senior Seminar on Architectural Criticism in Essay Form," which is led by her colleague Suzanne Stephens.

It is too soon to tell if students will go on to establish careers in architectural history, criticism, or the graphic arts. Ultimately, most of Barnard's architecture majors wind up in graduate school, typically Harvard, Yale, Princeton or Columbia. Out of the 13 women who graduated last May, five went on immediately to Harvard, Princeton or Columbia. One deferred admission to travel and study in Europe for a year; and three decided to work for a while before applying. Only three may not continue in architecture. (Tragically, one graduate was killed in an auto accident.)

Prof. Robertson is proud of her former students' performance in graduate school. They may need to do some catching up with their peers who have more technical experience, but the investment in a liberal arts degree does pay off. "They're well equipped to work, and they maintain their interest in architecture, which is sometimes hard to do in graduate school. They're pretty level-headed, and they have powers of evaluation. And, they're not overly competitive, that is, they're not overly worried about their performance relative to others but are con-

cerned instead about their personal growth as architects. And they do well."

The success of the program's graduates has not bred any complacency on the part of its students or faculty—the famous Barnard capacity for critical thinking is as sharp as ever. Molly Reid recalled a pervasive emphasis on graduate study at a few select institutions which cut down on students' options to explore other aspects of the field, or to study at schools which offered a different perspective of the profession. For Nancy Gorman '86, the program was neither practical nor intellectual enough. She designed her own double major in Architecture and Urban Affairs, in order to add a "practical, socially responsible" focus to her studies. "You never really work on your own personal theory of architecture," she said, citing the senior seminar on architectural criticism as the sole opportunity for such study.

Faculty and students agree that the place of theory within the program could be more secure. Charlotte Milholland, a January '85 graduate who works for Wasserman and Waterhouse, a Manhattan firm, doesn't think that architectural theory is neglected, but does believe there should be more support for students' own preferences regarding their studies. "Students have ideas and should have a say in the curriculum, in the choice of critics to be asked to speak to the seminar, and in what makes a good course of study," she said. She has compiled a journal of critical essays on architectural education entitled *Zero Hour* which will be available this spring at architecture bookstores across the country.

Both Donna Robertson and Susana Torre agree that

“It doesn’t matter how well you draw if your ideas aren’t rich.”

less class time is spent on theory than on drawing and design, and they look to the undergraduate architecture organization Nexus to fill the gap with lectures, field trips, exhibitions and study groups. Prof. Torre believes further that making the students responsible for this vital part of their education gives them both experience in dealing with professionals in the field and a greater measure of self-determination in their studies.

The hazard in relying on a student organization to fulfill academic goals is the tenuous connection between successive classes. Without strong sponsorship by the faculty, the effectiveness of Nexus varies from one class to the next, along with its contribution to the students’ intellectual lives. A strong ongoing commitment by the faculty is necessary to secure the role of Nexus as a stimulating forum on the art of architecture.

Barnard’s architecture program is clearly the result of the increased interest among today’s students in early career planning. One senses that Donna Robertson as director and advisor to Nexus, and Susana Torre, teaching the Junior Studio, keep vigilant watch over the program’s development, carefully balancing the technical and the humanistic sides, continuing to guide their students in both their intellectual and their professional lives. Prof. Robertson thinks restoring the “Fundamentals of Architecture” and “Advanced Graphics” courses may be worthwhile. Prof. Torre would like to establish a cross-country “old girl” network of alumnae working in the design professions to give advice and support to graduates entering the field.

Amid the pressure to add more technical courses and the professional attractions of “networking,” eloquent supporters of the liberal arts tradition can still be heard. Charlotte Milholland remembers a recent evening when she found herself rising from an audience of 100 people to respond to a speaker at the Urban Center. She talked for five or ten minutes, confident of her ideas and her ability to express them. She credits her poise that night to her time at Barnard. “Giving an architectural presentation and explaining it to a group of fifty people helps your self-confidence,” she said. “And it’s a good major for those who don’t continue. It’s a great education in analytical and philosophical problem-solving, abilities one can bring to all sorts of endeavors. And even if majoring in architecture is the thing that makes someone decide not to continue in the field, she would be glad she had tried it. It just makes walking down the street better.”

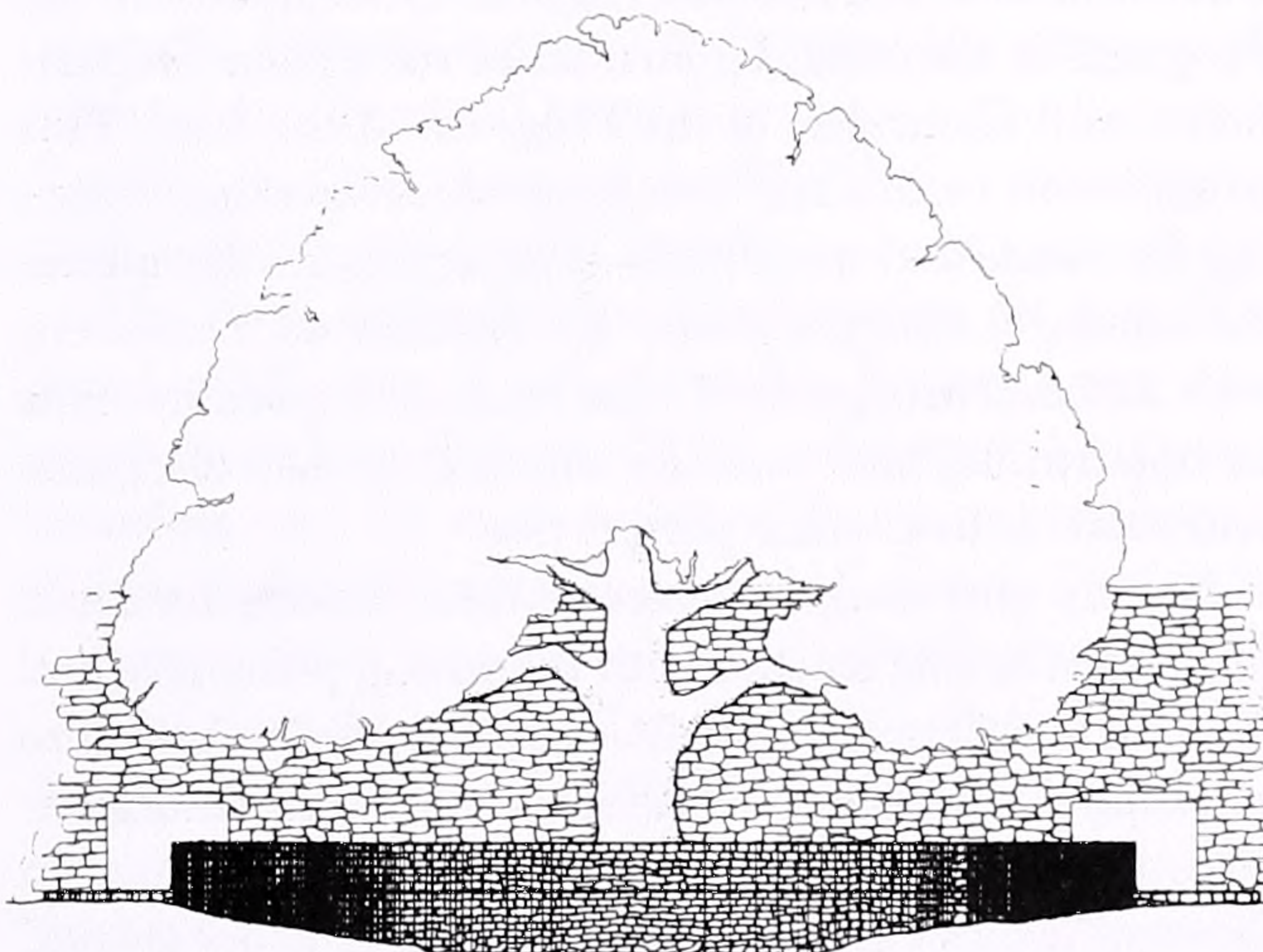
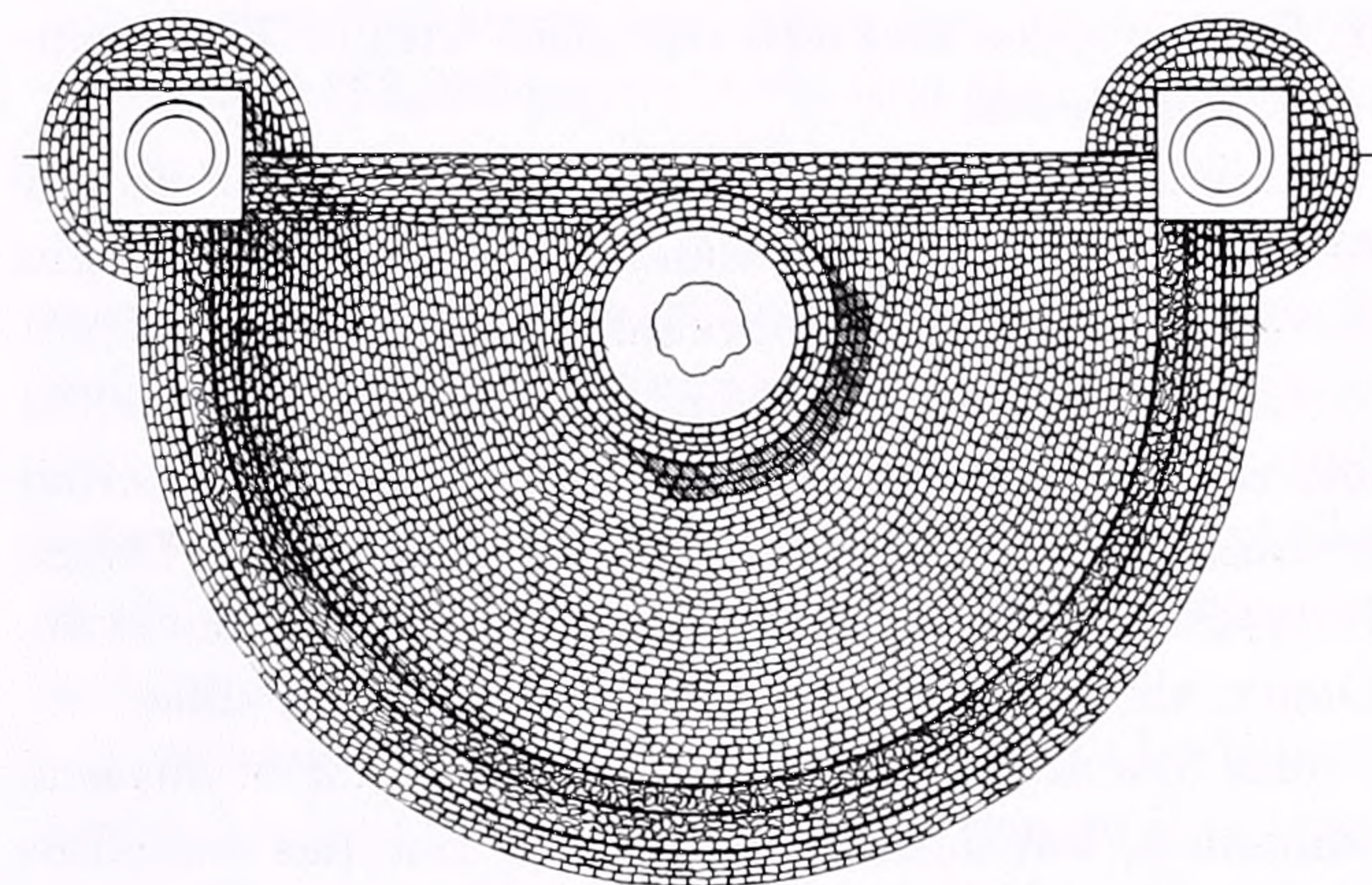
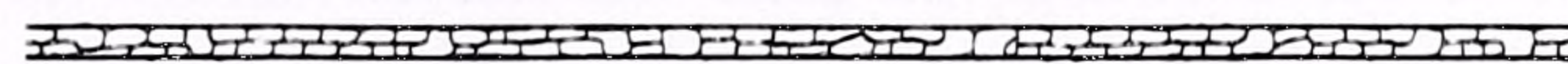
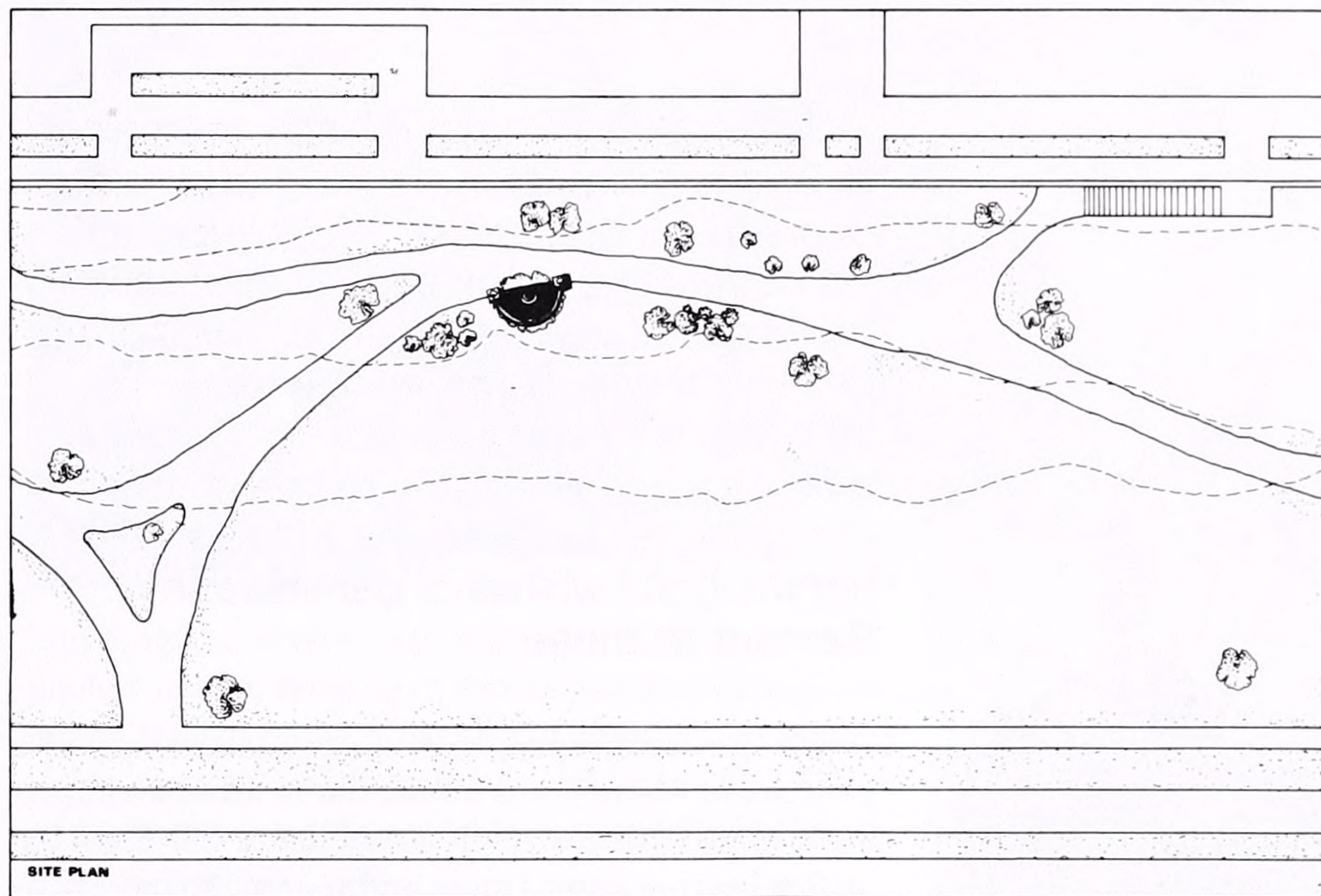

PARK SHELTER

PLAN AND ELEVATION

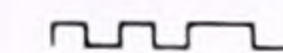

Hope Dana '85, *Design for Park Shelter*. To insert a place for rest and contemplation at a specific site in Riverside Park.

# Jeanette Roosevelt Retires

Jeanette Schlottmann Roosevelt came to Barnard in September 1951 and has been an integral part of the College both “at home” and in the eyes of the outside professional world ever since. This spring she was the students’ choice to win the 1986 Emily Gregory Award for outstanding teaching, and when she retires at the end of this academic year, she will take with her the good wishes of generations of Barnard alumnae.

Tall, gracious, open, and compassionate, she is a presence of whom one is aware, but never in an imposing manner — like her gentle accent that is still Texan but on first hearing sounds more midwestern. To those of us who were students in the fifties, Jeanette Roosevelt has remained refreshingly the same. Her soft red hair reverts to the bangs in which it was originally styled, even though it is frequently pushed back absent-mindedly. Her blue eyes can crinkle mischievously, focus inwardly, or penetrate like a laser beam. As a dancer she moved in a sustained manner that was surprising and beautiful in its flowing speed that took the space with it. That quality is still present.

Born and raised in Denton, Texas, she received her BA and MA from Texas Women’s University and taught there for eleven years before taking a leave in 1950-1951 to study dance with José Limón in New York. She fell in love with Barnard’s city, and except for a five year period at Connecticut College, where she headed the Dance Program and the highly respected summer School of the Dance, she has been enriching Barnard ever since.

Her first assignment was as an instructor in physical education, but dance was her love. She has served as Coordinator of the Dance Program, Coordinator of the Program in the Arts, Chairman of the Dance Department, and Chairman of the Program in the Arts. This progression took thirty-five years of unwavering lobbying for dance and the other arts as legitimate disciplines for scholarly study, a stance she defends as “consistent with a liberal arts point of view because it gives students an opportunity both to study within their own discipline and relate it to a wider perspective.”

Faculty and students agree in their descriptions and appraisals of this teacher with the strong principles and clear faith. When Jeanette Roosevelt commits herself to something — Barnard, a student, a program, an organization, her church — she is, in the words of Prof. Sandra Genter, “unceasing in her efforts and fierce in her loyalty.” To talk to her is to communicate with an individual who

is supportive, encouraging, a good listener, and very much present in her attentiveness. Her attitude towards her students has always been akin to a sense of family — she follows the “child” after she leaves, and the welcome back is with the same caring concern and acceptance.

The other side of allowing a student to become what she is or could be (she describes Barnard students as “alert to opportunity and possibility and able to focus on what they want and to go after it”) are her own compulsive work habits and sense of perfection. Jessica Fogel ’77 calls her the “glue” behind the scenes who puts energy into things most people do not see, such as cleaning the Annex closet in the summer! Prof. Barry Ulanov, with whom she has taught many seminars, notes that her honesty always prompted her to develop herself further in order to teach. This meant constant investigation and deep reading in areas that were not her expertise. He recalls “the amount she has not had to do and taken on as a major responsibility.”

Walter Sorrell, the dance historian who was an adjunct at Barnard for ten years, recalls his first meeting with Jeanette Roosevelt at Connecticut College. He was walking along the road, suitcase in hand and lost, when a car stopped and the driver asked where he wished to go. When he said he was looking for the Director of the Festival he was told to “hop in.” Only after they had arrived at their destination did she reveal that she was the person he was seeking.

She has shared many courses with her students: Dance History, Introduction to the Arts, Junior Colloquium, Senior Seminar, Modern Dance, Posture and Relaxation, Tap Dance. She also played a large part in creating the Program in the Arts, has spent innumerable hours critiquing creative projects, and rarely misses an alumna’s performance or exhibit. To her, “teaching is a collaborative effort that should be exciting to do together — a way of life that is part of you.”

One warm May evening in the mid-fifties, just after exams were over, Jeanette invited a few student dance enthusiasts to her apartment on Patchin Place, one of those hidden enclaves in Greenwich Village, a neighborhood in which she still lives. She served some elegant desserts, including homemade strawberry shortcake, and iced mint tea. After a lively discussion that centered on our plans for the summer and the future, we left our teacher’s home, and, strolling along, caught a glimpse of her neighbor, e.e. cummings. His bald head shone in the lamplight visible through an open window. To me, this incident typifies Jeanette Roosevelt. That night she created an environment in which we students were encouraged to investigate ourselves. Leaving her in an aura of warm self-confidence, we were open to absorb the image of the American poet — an image she seemed to have arranged and for which she had somehow prepared us.

—*Dawn Lille Horwitz ’55*  
*Coordinator, Graduate Program*  
*in Dance, City College*



Jeanette Roosevelt

# All About Translation

by Sarah Kennedy '86

One of the beauties of life on a college campus is the endless round of scholarly events that take place outside the classroom and are open to all members of the college community. Such an event is the annual International Conference on Translation, which has been held at Barnard every November for the past three years and has had a more exciting program every time. The conference director, Professor Serge Gavronsky, conceived of the idea in the first place, and has been successful in obtaining support from the New York State Council for the Humanities. Additional funding was provided by the Virginia C. Gildersleeve Fund, which was originally established by a gift from the Associate Alumnae. As a result of these and other grants, the conference fee was a remarkably low \$25, with a special rate of \$10 for students and senior citizens.

This year's conference brought together an array of poets, prose writers, and people who translate their works into other languages, as well as actors who interpret them in a different way. Several of the sessions dealt specifically with translation between East and West, including "Lecture on a Top Secret," with slides, by the artist Arakawa and his wife, poet Madeline Gins '62. Others featured such writers as Robert Bly, Gary Snyder, and Arthur Sze. Konrad Czyski of the Barnard French department shared one session with Japanese writer Masachi Miura, with Professor Barbara Stoler Miller '62 as moderator. The last of the eleven sessions looked at works in translation from the publishers' point of view.

In addition to a presentation on "French Writers and their American Translators," there was a session in which novelist William Styron talked with Maurice Rambaud, who has translated *Sophie's Choice* and 28 other American novels into French. I was surprised to learn that the two had never met or talked before. Rambaud is a professor of English and American literature at the University of Paris IX whose other translations include works by John Updike, John Barth, and Donald Barthelme.

Noting that relatively few foreign works are translated



Bob Welsh, Jr.

into English, Styron referred to the U.S. as a "xenophobic" nation, refusing to look outward and tending to ignore foreign books. That lack of interest even extends to books in general, he believes, and he has found a far more passionate audience abroad, especially in France, than on his native soil.

Styron first became aware of the contrast between his popularity abroad and at home in 1960, when he was living in Rome. A Frenchman appeared at his door one day and asked if he could translate his latest novel, *Set This House on Fire*, which had been pummeled in the U.S. The translation sold 70,000 copies, compared to the average sale for novels in translation of 4,000. Styron's crowning achievement in France was *Sophie's Choice*, which sold 163,000 copies in the first nine months after publication, more than 300,000 over a three-year span.

In addition to the interest of the French in other cultures, Styron attributes his success in France to the skill of his translators. For his part, Rambaud believes that Styron succeeds by developing a perfect unity between style and substance. There is nothing puzzling in the style, so the reader does not become sidetracked and can focus on the content.

Rambaud also believes that the French like Styron's novels because he writes about experiences that touch them. They can relate to Sophie, in *Sophie's Choice*, for example, because many of their own lives were greatly affected by the war. Other American authors, such as Updike, do not acquire a mass following abroad because they write of experiences specific to American culture.

The most difficult part of translating an American novel into French, Rambaud said, is finding a way to express American dialects: "The metaphysical task is to translate with the same emotion." In the case of Styron's Negro dialect, he tried to achieve the correct effect by dropping the "r" in words—leaving only the vowel sounds—providing the word still made sense. He had also had trouble translating the Yiddish in *Sophie's Choice*, but now that the two men have met, he joked, he will not hesitate to call for help if such problems arise in the future.

*continued on page 18*

Professor Serge Gavronsky and translator Maurice Rambaud look on as novelist William Styron uses both hands to reinforce his views on the state of the American novel at home and abroad.



Literary agent Deborah Karl '80 with sister, Rebecca Karl '81. In addition to her success with Winnie Mandela's autobiography, Deborah represented a South African novel, *Poppie Nongena*, by Elsa Joubert, which was published in January. Now in translation prior to publication in the U.S. is *The Piano Player*, a novel by the Austrian writer Elfriede Jelfnek. (On the other side of the world, Rebecca Karl teaches English at a university in China.)

# Child Care Through the Centuries

by Alice Ribbink

At commencement exercises at Barnard last year, Marian Wright Edelman issued a cry from the heart on behalf of children, especially those born in poverty. She cited the enormous sums spent on defense, contrasting shrilly with the penny-pinching where children are concerned. This made me wonder whether we had come full circle, back to the point—more than 2400 years ago—when Socrates wrote: “If I could only climb the highest mountain I would shout to the people below, why do you spend all your time gathering riches when you care so little for the children to whom you will have to leave it all one day?”

There are different ways of looking at child care through the ages and its development to modern standards. At times when human life was of little value and the life of a child was deemed worth even less, the general consensus of opinion was that a child, lacking the ability to think rationally, resembled an animal more than a human being. This attitude to children can be interpreted in various ways.

In the view of Lloyd de Mause, “The further back in history one goes, the lower the level of child care, and the more likely children are to be killed, abandoned, beaten, terrorized, and sexually abused. . . . The history of child care is a nightmare from which we have only recently begun to awaken. . . . There is something mysterious about the silence of all these multitudes of babes in arms, toddlers and adolescents, in the statements men made at the time about their own experience. It is of course not love which the parents of the past lacked, but rather the emotional maturity needed to see the child as a person separate from themselves. A hundred generations of mothers tied up their infants in swaddling bands and passively watched them scream in protest because they lacked the psychic mechanism necessary to empathize with them. Only when the slow historical process of parent-child evolution finally established this faculty through successive generations of parent-child interaction did it become obvious that swaddling was totally unnecessary.”<sup>1</sup>

In a contrary vein, the Frenchman Philippe Ariès, had written earlier: “The idea of childhood did not exist; this is not to suggest that children were neglected, forsaken,

or despised. . . . The idea of childhood is not to be confused with affection for children; it corresponds to an awareness of the particular nature of childhood, that particular nature which distinguishes the child from the adult, even the young adult. . . . People had no idea of what we call adolescence, and the idea was a long time taking shape.”<sup>2</sup>

Who is right? Was it a lack of empathy or a lack of awareness? It is precisely the example given by de Mause that argues *against* a lack of empathy and *for* a lack of awareness. Swaddling goes back to antiquity and was considered an act of compassion!

“ . . . as for thy nativity, in the day thou wast born thy navel was not cut, neither was thou washed in water to supply thee; thou was not salted at all, nor swaddled at all. None eye pitied thee, to do any of these unto thee, to have compassion upon thee. . . .”<sup>3</sup>

Physicians felt that swaddling would “shape the child and keep the limbs straight”<sup>4</sup> or prevent it going on all fours like other animals. Some honestly believed that incorrect swaddling would have the most dire consequences, recommending tight swaddling “lest the babe catch a cold or jaundice.”<sup>5</sup>

It is interesting to note that, except for the early Greek and Roman writers, nearly all original observations concerning children’s diseases came from barber-surgeons or botanists with a leaning toward anatomy. Physicians were not concerned with children. This is all the more odd as the founder of medical science, Hippocrates, pointed out the special features of diseases in childhood. The early physicians and philosophers even realized that congenital defects might have embryological origins instead of resulting from the mother being frightened during pregnancy, a belief which took root in subsequent centuries. Unfortunately, Soranus (98-117 A.D.) relegated the diseases of infants and children to midwifery. A precedent was thus established which was to last down to our day, “. . . an association which was to hamper and obstruct progress in the study of diseases of children until the mischief of it began to be recognized at the end of the last century. . . .”<sup>6</sup>

The study of diseases in general seems to have come to a standstill in the early Middle Ages. The barber-surgeons were regarded as “charlatans” by the medical profession and as such “beyond the pale.” Not weighed down by medical dogma nor hampered by learned medical preconceptions, they kept their eyes open, reported what they saw, and sometimes even attempted to correct congenital defects. They were consulted by people far and wide, and 13th century barber-surgeons traveled around Europe treating patients here, there, and everywhere—as if they were living in the jet age.

Generally speaking, the writings of the barber-surgeons and anatomists, often illustrated by well-known artists, are a better yardstick of the advancement of pedi-



Alice Goslinga Ribbink '52 is a medical translator/editor. A resident of The Netherlands, she is Honorary Secretary of the International Pediatric Surgical History Club.



Marian Wright Edelman, President, Children’s Defense Fund, at Commencement 1985: “I believe that American children need defense against the enemies within. . . . It will take never-ending citizen monitoring to protect our children against poverty and nuclear disaster. . . . but change is possible.”



atrics and pediatric surgery than the numerous important medical tomes. Spina bifida, for example, was first described and named by Nicolaas Tulp, a 17th century Dutch anatomist, who had Rembrandt van Rijn draw a beautiful and explicit picture of the anomaly. (Tulp is seen in Rembrandt's painting of "The Anatomy Lesson.")

If physicians did mention infants and children, they would often copy what others had written before them. Some writers resorted to sheer plagiarism, publishing a rehash of the early Greek and Roman writings as their own. None of them digressed far from midwifery and they all addressed their writings to laymen, keeping health care of children firmly within the domain of parents. If parents could not cope with an illness, they would leave their sick child at an orphanage, occasionally reclaiming her upon recovery. Doctors were not involved.

The prevailing attitude toward children is an aspect of the structure of a society, which was for centuries built on misconceptions. The basic premise was that the period between birth and the age of reason had nothing to offer and consequently should be completed as quickly as possible. Children were educated in order to deliver them from that unhappy state of nonexistence. In *Thoughts on Education*, published in 1693, John Locke opened people's eyes with his innovative description of Childhood as a developmental phase distinct from Adulthood. He recommended adapting the development of the child to her natural inclination, instead of expecting her to become an adult as soon as she was removed from the nursery. Lucretius (96-55 B.C.) had recommended tolerance for the slowness of growth to maturity seventeen hundred years earlier, but it was only after Locke kindled people's awareness that things began to change.

It was still a long time, however, before physicians began to see the health care of children as their concern. When George Armstrong, a London physician, opened a "Dispensary for Children" (mainly of the poor) in Holborn in 1769, he was met with abuse by his colleagues. He devoted his entire life and fortune to the care of sick children and relief of the miserable conditions under which poor children had to grow up.<sup>7</sup> Even Armstrong did not foresee a time when children would be admitted to hospitals for medical treatment, and when he died, nobody took up his cause.

Until the 1850s, when children's hospitals began to appear all over the world, sick children who received any professional medical care at all were treated by surgeons and not by physicians. One of the first indications of change in the attitude to children is seen in a textbook published in London in 1860. The author, a surgeon at Guy's Hospital in London, was a strong advocate of the use of chloroform, especially in the treatment of children. "Under the present circumstances," he wrote, "we are never justified in inflicting severe pain on children."<sup>8</sup> In this century such concern has accompanied enormous



Terra cotta infant clothed in swaddling bands, by Andrea Della Robbia. From the frieze of "Ospedale degli Innocente" (Foundlings' Home), Florence, Italy. The artist worked on the frieze from 1463 to 1466, doing a series of infants in various stages of swaddling.

strides in medical progress, such that a modern pioneer in pediatric surgery, Sir Lancelot Barrington Ward, has said, "The adult may safely be treated as a child, but the converse can lead to disaster." This is a complete reversal of the attitude that prevailed for so many centuries.

Now that we have finally become aware of "the particular nature of childhood," however, it seems that our society is losing its empathy. Marian Wright Edelman spoke about the children who know only "relentless poverty and the hunger and disease it breeds." In today's world, they are often treated as if they are responsible for their sorry condition. In our own lives we know we should allow our children to grow slowly to maturity, but instead we force them to grow up at an ever increasing pace. As soon as they can walk, they are forced onto the treadmill of Achievement Until Death. Not even their toys are truly childlike. If we are not careful, we will complete the circle, and childhood will again be a nightmare.

#### REFERENCES

- <sup>1</sup> Lloyd de Mause, *The Evolution of Childhood*, New York, The Psychohistory Press, 1974.
- <sup>2</sup> Philippe Ariès, *Centuries of Childhood*, New York, Jonathan Cape, 1962.
- <sup>3</sup> Holy Bible, *Ezekiel*, Chapter 16, verse 3.
- <sup>4</sup> Pago Bagellardi, *De Infantum Aegritudinibus et Remediis*, Padua, 1472.
- <sup>5</sup> Stephen Blankaart, *Verhandelinge van de Opvoeding en Ziekten der Kinderen*, 1684. Reprinted by Hollandia, 1966.
- <sup>6</sup> George Frederic Still, *The History of Paediatrics*, 1931. Reprinted by Dawsons of Pall Mall, 1965.
- <sup>7</sup> George Armstrong, *An Account of the Diseases Most Incident to Children from their Birth till the Age of Puberty*, London, T. Cadell, 3rd edition 1771.
- <sup>8</sup> J. Cooper Forster, *The Surgical Diseases of Children*, London, Parker & Son, 1860.

## Getting Here . . .

*continued from page 3*

“regular” applications, and then transfers.

There are several elements in the College’s expectations of its applicants. As stated in the catalogue, the “recommended” high school program includes four years of English, three years of mathematics, three or four years of a foreign language, two years of science with laboratory, and one year of history. “An introduction to a second foreign language is generally useful,” and “the possible addition of music and art” is mentioned.

The prospective student must take the Scholastic Aptitude Test and three Achievement tests. She must complete a personal information sheet, consisting of several short-answer questions designed to help the reader get to know the applicant and her cultural, extracurricular, and academic interests. She must submit a personal essay on a subject of her choice, a high school transcript including grades up to the middle of the senior year, and two recommendations — one from an academic teacher and one from a guidance counselor or principal. She is also invited to send any other material she feels will aid the admissions committee in considering her candidacy.

When it comes to reading the more than 2000 freshman applications, it is necessary to have a system which will provide for consistency of evaluation throughout the group. As first steps the applications are sorted by state and the Admissions staff is organized in sub-committees of three. Each state is assigned to a sub-committee. Using a scale of one to ten, each reader ranks every applicant and the sub-committee then meets to reconcile their votes.

What they are looking for, first of all, are academic strength and intellectual curiosity. Secondary criteria include leadership ability, artistic talent, and athletic prowess. In addition, unusual life experiences or underprivileged family backgrounds may affect committee considerations. Detailed discussion continues until they reach consensus to “admit” or “reject”—one candidate at a time. All decisions are then reviewed by the Director.

While the reading process goes on behind closed doors, the rest of the campus becomes an “Open House” for applicants who want to see what life at Barnard is “really” like. They are invited to come to Barnard for one of three two-day programs, which are scheduled to coincide with winter or spring vacations at most high schools. They stay in the Barnard dorms as the guests of current students, eat Barnard food, attend Barnard classes, meet members of the Barnard faculty.

Elizabeth O’Shea believes the Open House program benefits both the College and the students. They get a much better sense of the Barnard experience than any viewbook or interview could provide. Then, if they are accepted, they can be more comfortable making Barnard their choice “and we build our yield.”

The Admissions cycle is complete when, on a pre-determined date in April (this year it was April 9), letters to all the applicants have been signed, sealed, and sent off in the mail. In the painstaking process to build a class of 500-525 talented young women who will flourish at Barnard and add to its strength, the final decisions are now in the hands of the students.

---

## Five Not-So-Easy Pieces

*continued from page 7*

form as well as “normal” subjects in this area although they perform poorly on tests involving explicit memory. Miriam’s hypothesis is that implicit memory works through a process of activation that is tied to the quality of exposure; for example, a person will have an easier time remembering a word if she has seen it written out than if she has seen only a picture of the object. She developed a controlled experiment in which her subjects, all Barnard students, were divided into three groups and given a number of words and pictures to study. Preliminary results indicated that her hypothesis is valid.



A major new element in the Barnard curriculum is the Women’s Studies Program, in which students can choose from a wide variety of courses in several disciplines. Ava Rose chose a concentration in English and French, and in her thesis she uses French feminist theory and psychoanalytic theory of the relationship between desire and language to explore the possibility of finding in Virginia Woolf’s writings the particular experience of a woman in patriarchy.

Hysteria, in Ava’s view, represents a subconscious protest against patriarchy. Unable to speak her anger, the hysteric expresses it with her body: “Hysteria represents the corporealization of psychic states. Hysterical women are experiencing a psychological crisis which manifests itself physically. They textualize their body by writing their protest on it.”

Ava compared Virginia Woolf’s written protest to the hysteric’s corporeal one. Both Woolf and the hysteric have trouble discovering a place for their desire. They experience themselves as other since patriarchal language denies the existence of female desire. In *To the Lighthouse*, the shifting of points of view reveals the difficulty that both Woolf and her female characters experience in appropriating subjectivity. The narrative style allows characters to be simultaneously subject and object, experiencing an hysterical crisis of identity.

Ava credits Woolf with winning a literary battle by asserting her female voice. By refusing patriarchal conventions, she can express her inner psychic state. She becomes the subject by writing herself. Ava believes that Freud’s hysterics could not totally recover because they never became subjects; psychoanalytic theory told their story.

# Green Grows New York

For most city dwellers, especially in New York, a patch of green here or there is something to be noted gratefully as they pass, but not usually a reason to break stride. For three Barnard alumnae in Manhattan, however, the presence of growing things is a consuming interest, as they care for trees on city streets, help residents who want to cultivate vacant lots, or organize the marketing of fresh farm products.

## STREET TREE CONSORTIUM— Marianne Holden

There was once a Tree that Grew in Brooklyn which achieved world fame as the “hero” in a lovely novel. In fact, some would say that all the trees that grow in Brooklyn, and Manhattan and the Bronx, and many of those in Queens and Staten Island as well, deserve to be called heroes, just for surviving. They are not totally without friends or protection, however, thanks to the New York City Street Tree Consortium, whose executive director is Marianne Holden '76.

The Street Tree Consortium started in the mid-'70s, when the city's greening community became concerned about severe cuts in the Parks Department budget for tree planting and maintenance. Its programs have provided New Yorkers “with an opportunity to do something concrete to improve their world, something they can do with a group of neighbors or by themselves.”

There are about 600,000 street trees in New York's five boroughs (mostly London plane trees, ginkgos, and honey locusts), and they die at the rate of 13,000 a year. The Consortium fights for city funds for tree planting and care, plants new trees, and tries to engage the public in their care. More than a thousand city residents have paid the \$15 fee to take its six-session course so they can



Marianne Holden caring for one of the city's 600,000 street trees.

become members of the Citizen Pruner Corps. They prune street trees, cultivate the soil around them, water and feed them, and attempt to guard them against vandals, dog walkers, message nailer-uppers and bicycle chainers.

An innovative project sponsored by the Street Tree Consortium in partnership with the Association for a Better New York and the Council on the Environment of NYC seeks to turn “Trash into Trees.” Businesses are urged to recycle their waste paper, thus conserving trees, reducing the amount of waste to be placed in landfills or incinerated, and providing funds from the sale of the recycled paper to plant new street trees.

Street trees must survive not only constant assault by the motoring public, pedestrians, and pets. Their growing conditions include air that is laden with carbon monoxide, sodium vapor lights that keep them up all night, lack of water, and soil that is not really soil at all but a compacted concoction of cement dust, salt, broken concrete, smashed glass, and styrofoam fast-food cartons.

“Maintaining this vital urban resource is both a personally satisfying and socially responsible activity,” notes Marianne Holden, who was an Environmental Conservation and Management major at Barnard. She spent an undergraduate summer with Israel's Environmental Protection Service, worked in urban planning and in housing finance, and took the Consortium's course in street tree maintenance before becoming its executive director.

## GREENMARKET by Marcy G. Roth

When I tell people in New York that I work for Greenmarket, they sometimes respond with a vague comment about “farmers and trucks around town.” But more often the face lights up, the eyes twinkle, and I hear which farmer has the tarest winesaps, the most peppery argula, the juiciest peaches. For tens of thousands of New Yorkers, Greenmarket, a program of farmers markets operating six days a week at 19 locations in Manhattan and Brooklyn, is the *only* place to shop for food.

Greenmarket was born when Barry Benepe, an architect and urban planner, couldn't find a tomato that tasted like a tomato anywhere in New York in August. He knew those tomatoes were out there, ripening on farms within



Greenmarket at Union Square, one of the three year-round locations.

80 miles of Manhattan. He also knew that encroaching development and low wholesale prices were threatening the survival of farming in the region. Direct marketing—farmers selling directly to consumers—would benefit both the beleaguered growers and city dwellers who had never tasted truly fresh corn.

Ten years ago this July, the first three farmers set up their stands in an empty lot on the corner of 59th Street and Second Avenue. After five years of great success, the 59th Street site was lost to construction, but the markets are now a thriving project of the Council on the Environment of New York City. Over 150 vendors sell an extraordinary array of fruits, vegetables, meats, fish, poultry, eggs, cheeses, milk, jams, preserves, New York State wines, and baked goods. Gross sales in 1985 totaled more than six million dollars, and for many of the farmers Greenmarket provides their entire livelihood. For the consumers, the variety and freshness of the produce cannot be matched, and prices average 30% lower than supermarkets and greengrocers.

Administratively, Greenmarket is determinedly non-corporate, so that staff members handle a variety of jobs. The pace is hectic, save for brief lulls during blizzards and before planting time. As office manager, I am responsible for a variety of details, including obtaining permits from city agencies, helping a new farmer decide which market would suit him best, locating a farmer who sells organically raised, free-range chickens, or regretfully telling that baker of excellent, sugar-free, whole-wheat Irish soda bread that we have no more room. And with all of that, what a privilege it is to wander amid the piles of beautiful fruits and vegetables, hobnobbing with the generous, hearty farmers and basking in the praise and gratitude of delighted customers. This glorious mix of city and country is one version of the Barnard goal of “having-it-all.”

## OPERATION GREENTHUMB— Jane Weissman

Rutabagas in Bushwick. . . pumpkins in the South Bronx. . . bell peppers in Harlem. . . Thanks to Operation GreenThumb and the dedicated hard work of neighborhood gardeners, such products are not just growing, they are thriving, in lots where the only prior crops were heaps of rubble. The Department of General Services' Operation GreenThumb leases city-owned vacant lots to non-profit community groups for \$1 a year for the purpose of establishing neighborhood gardens.

Operation GreenThumb (OGT) also provides materials and know-how to community gardeners, helps coordinate the annual City Gardeners' Harvest Fair, and publishes a quarterly newsletter, all supervised by director Jane Weissman '68.

Potential garden sponsors, such as churches, schools, senior citizen centers or drug rehabilitation centers, must first obtain a lease for a vacant lot. Next comes the monumental task of transformation. The Department of

Sanitation helps haul away the mountains of rubble, and OGT provides tools, soil, fencing, and trees, as well as workshops on planting, cultivating, harvesting, and canning. Scattered throughout the City, more than 675 OGT gardens are now at various stages of development.

An annual highlight is the Harvest Fair, held in Brooklyn in August, where prizes are awarded for the best city-grown vegetables and flowers. “Artists in the Gardens” is another OGT special program; artists are given a beautiful, lush setting on which to display their art, and community residents get the opportunity to work with the artists and view the art “right next door.” Two artists who are working on murals for the program are Robin Michals '81 and Kristi Pfister '78; their murals in Bedford-Stuyvesant and Coney Island will incorporate portraits of community gardeners.

Before she became director of Operation GreenThumb in 1984, Jane Weissman was Assistant Director of Greenmarket, where she coordinated the operation of the farmers' markets around the city. She also helped set up a community recycling center in Greenwich Village.

---

## All About Translation

*continued from page 13*

During the “Publishers' Roundtable,” seven speakers from the publishing world presented their views of translated work. Aaron Asher, Executive Editor of Harper & Row, shares Styron's feelings about America's attitude to foreign books, noting that ten times as many American books are translated into German, for example, as German books into English. He sees historical and cultural factors at the root of this prejudice: Europeans believe that America controls their destiny and that by reading material from the U.S. they can know their own future. Americans, on the other hand, feel superior because of political and financial strength, so they are indifferent to European works.

Focusing on another aspect of literature in translation, Deborah Karl, Barnard '80, spoke of the difficulty of placing foreign authors with publishers in this country. As a literary agent with Sanford J. Greenburger Associates, she has found that few American editors can read other languages. If only one member of a publishing house is able to read a work, it will be difficult to develop enthusiastic support for its acquisition. Since there is also likely to be built-in resistance based on the expectation of low sales, a foreign book is often kept from the American market without ever being tested.

The highlight of an agent's career is often the placing of an important book that nobody seems to want. Deborah Karl had such an experience with *A Part of My Soul Went With Him*, an autobiography by Winnie Mandela. The author was unknown when Karl first read the book but she managed to sell it to W.W. Norton, and it has become a huge success. Although she also is concerned about Americans' lack of interest in books, “this experience renewed my faith that there are people out there who read good books.”



Jane Weissman at a gardeners' conference.

## LETTERS

*continued from inside front cover*

must be healthy and willing to learn another language, who can commit themselves to two years of service in a developing country, and who have training and/or experience in teaching, health services, math/science, and all phases of agriculture. Volunteers receive living allowance, medical care, and \$4,200 Readjustment (after two-year assignment). Further information can be obtained by calling us at 1-800-424-8580.

Loret Miller Ruppe  
Director

To the Editor:

We are two filmmakers who are in the preproduction stages of a documentary called "Career Girls," about the women who forged careers for themselves in the '30s and '40s. We are looking for women who fit that category and your alumnae sprang to mind.

These women—pioneers, really—have a powerful perspective to offer on the upheaval in women's identities they have witnessed in their lifetimes. We have begun gathering names and approaching women such as Millicent McIntosh and many others in publishing, finance, government, law, architecture, retailing, and medicine. We hope your alumnae will also wish to be interviewed, so that our film will be as accurate and wide-ranging as our subject deserves to be.

Anyone who wishes to speak with us should call us at 212-505-0235. We look forward to hearing from them.

Kate Purdie & Julie Talen  
Trouble in Paradise Productions  
New York, NY

### "So Many Men," So Poor a Choice

To the Editor:

I was thoroughly disgusted by Sharon Waxman's piece, "So Many Men, So Little Time" (Fall 1985). At first I thought it would be a clever satire focusing on how men think we still need them, but how independent (not unloving) many women now are. Instead I found an article that one might run across in a magazine from an all-girls' school or in *Cosmopolitan*.

Ok, there are still some women whose main goal in life is to find a good looking man. I thought Barnard taught different, more creative goals.

Two main complaints are: 1) the sexism and 2) the elitist tone. The article is superficial and full of stereotypes. It saddens me to think that the consciousness at Barnard has sunk so low that a decision was made to print this and to give it practically a full page.

Terry Snofsky '81  
Brooklyn, NY

# Call to Action On Aid to Education

Threats of cuts in federal aid to higher education have become routine in recent years—but there has been nothing routine about their impact. Even the Administration's own spokesmen acknowledge that the further reductions now being proposed would limit students' options, causing many of our most talented young people to turn away from institutions which would be best for them, simply because of cost.

Ever since the "GI Bill" opened the doors of colleges and universities to millions of Americans who could not have handled the expense on their own, higher education has been seen as one of the most worthwhile investments our government can make. Unfortunately, the "burden of proof" of the continued value of this investment has now fallen on the education community itself. Those who support diversity in higher education must speak up.

Members of Congress have heard too many tales this year about alleged luxuries enjoyed by college students. Now they need to hear the facts:

- The Administration's policies would undermine what many believe to be the greatest strength of the American higher education system: access to a variety of institutions, matching the diversity of students' talents and ambitions regardless of cost, ability to pay, geographic location, race, or sex.
- The cost of higher education is virtually the same at public and private institutions. The difference is in the *price* charged to each student. Financial aid must be provided in some form for nearly everyone. In public colleges, this aid takes the form of direct government support of capital and operating budgets; fees for all students, regardless of their ability to pay, are far below cost. At independent institutions, all students pay more of the cost, and aid is tied directly to ability to pay.
- At Barnard, as at most independent colleges, students and their families must contribute as much as they can afford before aid is awarded. Those who need help must first accept loans. Federal loan guarantees mean that the interest on these loans is deferred until the students graduate, and the rate is then below market rates, but the burden of debt even now can be staggering. Drastic reductions in the Guaranteed Student Loan program will make such loans unaffordable or even unavailable.
- Students must also accept jobs during the school year. Federal aid supports a "work-study" program, which is open only to students with need and represents a major source of school-year earnings.
- Corporations, foundations, and private individuals are already involved in the effort to keep independent colleges open to all. There are no untapped sources that might step in to fill the gap if federal aid is significantly reduced.

Your Representative and Senators will not know that you think federal aid to higher education is important *unless you tell them*. Please write to them today.\* Using as much of the information above as you think appropriate, ask them to reject the Reagan Administration's proposals for drastic reductions in federal aid for higher education.

\*If unsure of the full names and addresses of your Senators and Representatives, call the League of Women Voters.

# QA

Throughout the year, the Office of Alumnae Affairs is asked any number of questions about services available to alumnae at Barnard, privileges they enjoy on campus, and some of the "nuts and bolts" of college life. Answers to some of these questions are given below; others will appear in future issues. If you have a question which we haven't answered, let us know.

*The address for all College offices is 3009 Broadway, New York, NY 10027-6598. All phones are in the 212 area code.*

## **I've heard that alumnae can audit courses. Is there a fee? How do I sign up?**

Most Barnard courses are open to alumnae auditors at no charge. The permission of the instructor is the only requirement. (Laboratory and studio courses, seminars, spoken language courses, and courses in architecture, education and writing are generally not open to auditors.) Catalogs and other information are available in the Office of Alumnae Affairs, 221 Milbank. There is no formal deadline for registration but auditors are encouraged to sign up no later than the first week of classes. The Fall term will begin on September 4. All courses are given in the daytime.

## **I would like to visit the campus but I know that parking is a problem in New York City. If I come by car, where could I park?**

Since all spaces in the College's garage are assigned to faculty and staff, daytime visitors should use either of the two nearby commercial garages: PJ&A Garage on 122nd Street between Broadway and Amsterdam Avenue or Big Apple Garage on the east side of Broadway between 113th and 114th Streets. When an alumnae event is being held on a Saturday or in the evening, space is usually available in the Barnard garage (located under Altschul Hall and entered from Claremont Avenue).

## **I've lost my diploma. How can I get another one?**

Send a notarized letter stating that you have lost or misplaced your diploma to the Office of the Registrar. Include your name as it was when you graduated as well as a check or money order for \$10 payable to Barnard College. You may also apply in person at 107 Milbank. You will receive a new diploma in about eight weeks.

## **Can I have a private party on the campus?**

Yes, but only when classes are not in session. To make arrangements for an event to be held during breaks within the academic year, call Doris Miller in the College Activities Office (280-2096). Jean McCurry (280-8021) is responsible for use of campus facilities during the summer months. The most attractive rooms are heavily booked, so reservations should be made far in advance. Fees vary according to location.

## **I know a young woman who is interested in attending Barnard. Is it possible for her to get a guided tour of the campus?**

Tours led by student guides are available throughout the year. Individuals or groups are shown every part of the Barnard campus and get an overview of Columbia University. Appointments are recommended and can be made through the Office of Admissions (280-2014).

## **I am planning to enter/re-enter/make a move within the working world. Can I get help from Barnard?**

Absolutely. The Office of Career Services provides counseling for alumnae at every stage of career development. Appointments for interviews must be arranged in advance (280-2033). For alumnae outside the New York area, effective counseling can be conducted through the mail.

The Office also provides information about specific positions through its Job Seekers Newsletter; handles employer recommendations; and houses an extensive library of vocational literature. Its Contact File contains names of alumnae in a wide range of occupations who are willing to talk with other Barnard women about their work. (Although most of the Contacts are in the New York area, an increasing number are in other parts of the country.)

## **Although I went through Barnard with the Class of 19\_\_\_\_, I didn't get my degree until two years later. Can your records be changed so that I will get Reunion news and other mailings from my original class?**

Yes. Write a letter to Yvonne Untch, Alumnae Records Officer, 221 Milbank. Explain what you would like to have done and your class affiliation will be corrected.

## **I would like to make a contribution to Barnard in memory of a friend. What is the procedure for this?**

With your check, payable to Barnard College, send a letter stating that the contribution is being made in memory of (*friend's name*; also Barnard class, if any). If you wish to have someone in the friend's family notified of the gift, include that information also. You will receive an official receipt and your class will be credited with the amount of the gift, even if the friend is a member of another class.

## **Can I use the Barnard Library even if I'm not taking courses anywhere in the University?**

Yes. All alumnae have access to and may borrow books from Barnard's Wollman Library with a library card. To obtain a card, come to the Office of Alumnae Affairs, 221 Milbank, or call 280-2005 to arrange to have one left for you at the Library. There is no fee. Alumnae are subject to the same library policies as students.

## **My alumnae magazine is addressed to me as "Mrs. John Doe." Like almost every woman I know, I prefer to be called by my own name. Why doesn't Barnard adjust its records in this way?**

Names and titles on alumnae records are not changed without a specific request from the alumna concerned. The best way to have your record altered is to use the form which appears in every issue of the magazine. In this issue it is on page 39.

## **How can I get a copy of my Barnard transcript?**

Official copies of transcripts bearing the seal of the College and the signature of the Registrar can be sent only to another institution, business concern, or government office at the request of the alumna.

Requests should be sent directly to the Registrar; no orders can be taken over the telephone. Send your full name, including name while at Barnard, dates of attendance, and complete address instructions; the fee is \$2 per copy (payable to Barnard College).

# EVENTS IN THE ARTS

## New Books

**Rebecca (Trachtenberg) Alpert '71** and Jacob J. Staub, *Exploring Judaism: A Reconstructionist Approach*, The Reconstructionist Press, 1985, \$11.95/\$5.95.

"Being Jewish and American," "When Past and Present Conflict," "Women in the Rabbinate"—the chapters in this slim volume deal with contemporary issues and describe the Reconstructionist approach to being Jewish. Reconstructionism, a movement begun by Rabbi Mordecai Kaplan in 1922, has grown immensely in recent years.

**Rita Ecke Altomara '72**, *Hollywood on the Palisades*, Garland Publishing, 1983, \$38.

This book offers a comprehensive guide to the silent movies produced in Fort Lee, New Jersey, from 1903 to 1927, and includes cast lists and photographs of some of the stars.

**Louise Bernikow '61**, *Alone in America: The Search for Companionship*, Harper & Row, 1986, \$15.95.

Loneliness, pervasive and almost unmentionable, is a large part of many people's lives. Corporate executives, adolescents, gay people, the elderly, men and women from all walks of life experience the emptiness, as this important book reports.

**June (Rossbach) Bingham '40** and Norman Tamarkin, M.D., *The Pursuit of Health: Your Mind, Your Body, Your Relationships and Your Environments*, Walker and Co., 1985, \$16.95.

By learning how the "Intimate Connector," the central integrating force within, interacts with and is affected by four elements—mind, body, relationships and environments—people can discover why they're unhealthy and find the road to well-being.

**Joy Gould Boyum '55**, *Double Exposure: Fiction into Film*, Plume/NAL, 1985, \$10.95.

Exploring "the complex interactions among reader, novel, viewer, and movie," the author examines the translation processes that transformed eighteen novels into films. Includes classics such as *The French Lieutenant's Woman*, *Tess*, and *The Great Gatsby*.

**Suzy McKee Charnas '61**, *The Bronze King*, Houghton Mifflin, 1985, \$12.95.

New York City, with its subways, street people and Central Park, is the setting for this adventure-fantasy, as fourteen-year-old Tina searches for the evil, subway-dwelling monster who has stolen a statue of King Jagiello.

**Ellen (Cohen) Clarkson '62**, *Six Acts on a Flying Trapeze: Intermediate Conversation/Reading Text for ESL*, Prentice-Hall, 1986, \$9.95.

"When the student dares to let go and—like the trapeze artist—flies free," that is when inhibitions are overcome and learning occurs. Each chapter focuses on a literary passage, with related illustrations to be described and conversation ideas.

**Vicki (Wolf) Cobb '58**, *The Secret Life of Cosmetics*, J.B. Lippincott, 1985, \$11.50.

"Science is not the mysterious process for eggheads it's cracked up to

be." An entertaining mixture of history, scientific fact and easy-to-do experiments.

**Barbara (Kauder) Cohen '54**, *Coasting*, Lothrop, Lee & Shepard, 1985, \$10.25.

L.A.-born Metz ventures to New York City for an extended stay with Maddy, a friend from his camp counseling days. Slowly, friendship blossoms into romance.

**Barbara (Kauder) Cohen '54**, *Molly's Pilgrim*, Lothrop, Lee & Shepard, 1983.

Molly, a schoolgirl who emigrated from the Soviet Union, is ridiculed by her classmates when she brings in a Thanksgiving doll dressed like a Russian peasant. The 1985 movie made from this endearing story of prejudice and acceptance received an Academy Award in the category of live action short films.

**Linda (Schapiro) Collins '52**, *Going To See The Leaves*, Viking Penguin, 1986, \$15.95.

These eight unsettling stories quietly probe the fears and passions that simmer below everyday interactions and relationships. An impressive first collection.

**Renee (Brosell) Garrelick '62**, *Concord in the Days of Strawberries and Streetcars*, Concord Historical Commission, 1985.

In celebration of the 350th birthday of Concord, Massachusetts, the author has created a book that describes early twentieth-century life in the town through the recollections of its longtime residents.

**Elissa D. Gelfand '69** and Virginia Thorndyke Hules, *French Feminist Criticism: Women, Language, and Literature*, Garland Publishing, 1985, \$36.

This annotated bibliography provides a summary of French feminist theory for the period 1970-1982.

**Elizabeth (Kramon) Harlan '67**, *Watershed*, Viking Kestrel, 1986, \$12.95.

It's the hottest, driest summer in history, and Jeb and his brother Noel are growing apart as they grow up. The conflicts they face as each asserts his identity are thoughtfully portrayed.

**Zora Neale Hurston '28**, *Spunk: The Selected Short Stories of Zora Neale Hurston*, Turtle Island Foundation, 1985, \$8.95.

"Isis," "Sweat," "Book of Harlem"—this anthology of nine short stories reconfirms the talent of an extraordinary Black woman writer.

Pieces by **Zora Neale Hurston '28** and **Erica (Mann) Jong '63**, *The Norton Anthology of Literature by Women: The Tradition in English*, W.W. Norton, 1985, \$28.95.

Hurston's story, "Sweat," and Jong's poem, "Castration of the Pen," are included in this monumental work spanning six centuries.

**Jill Jonnes '74**, *We're Still Here: The Rise, Fall, and Resurrection of the South Bronx*, Atlantic Monthly Press, 1986, \$24.95.

Tracing the history of the South Bronx from its heyday in the first half of this century through its decline after WWII into the 1970s and on to the hesitantly hopeful period of renewal, the author tells the story of a

troubled borough with toughness and clarity. Foreword by Sen. Daniel P. Moynihan.

**June (Millicent) Jordan '57**, *Living Room: New Poems*, Thunder's Mouth Press, 1985, \$14.95/\$6.95.

Soweto, South Africa; Greensboro, North Carolina; Teotecacinte, Nicaragua—June Jordan's poems touch on the lives of struggling people around the world as she expresses the need to "help preserve and create living room on this only earth of ours."

**June (Millicent) Jordan '57**, *On Call: Political Essays*, South End Press, 1985, \$8.

In this second collection of political writings, the author explores racism both here and abroad, censorship, Black English and other topics, in a powerful, immediate style.

**Laurie (Gertz) Kirszner '66** and Stephen R. Mandell, *The Holt Handbook*, Holt, Rinehart and Winston, 1986, \$12.95.

Emphasizing experimentation and revision rather than error, the authors have put together an appealing, non-threatening writer's handbook.

**Laurie (Gertz) Kirszner '66** and Stephen R. Mandell, *Patterns for College Writing*, St. Martin's Press, 1986, \$12.95.

The third edition of a practical guide to writing for college students. Writing samples follow discussions of techniques.

**Norma Klein '60**, *Family Secrets*, Dial Books, 1985, \$13.95.

After years of friendship, Peter and Leslie become romantically involved. The subsequent divorces in both families and romance between Leslie's mother and Peter's father shatter their own romance and greatly alter their lives.

**Bettina (Liebowitz) Knapp '47**, *Archetype, Architecture, and the Writer*, Indiana University Press, 1986, \$27.50.

Examining the houses, temples, castles and other buildings that appear in the works of such authors as Ibsen, Kafka and Borges, Professor Knapp explores the interaction between the author's "non-individual collective unconscious" and the architecture.

**Bettina (Liebowitz) Knapp '47**, *French Theatre, 1918-1939*, Grove Press, 1985, \$11.95.

The period between World Wars I and II was marked by fundamental changes in all aspects of French theater—form, presentation and subject matter. The works of Jean Cocteau, Paul Claudel, Jean Anouilh and others are discussed.

**Susan (Landy) Littwin '59**, *The Postponed Generation: Why American Youth Are Growing Up Later*, Wm. Morrow, 1986, \$16.95.

As Martha Green, Director of Barnard's Office of Career Services, said in an ad for the book in *The New York Times*, "Readers . . . will get a rich understanding of these young people of the '80s and their situation in our society." An insightful book full of interviews with young people all across America.

Shoshana Kalisch with **Barbara (Lewittes) Meister '53**, *Yes, We Sang! Songs of the Ghettos and Concentration Camps*, Harper & Row, 1985, \$12.95.

These 25 songs, written and sung by Holocaust victims, helped to sustain hope when there was none. Presented in transliterated Hebrew and English translations with the piano accompaniment, the songs are interspersed with stories of their creators' lives and the author's own recollections.

**Regina Markell Morantz-Sanchez '65**, *Sympathy and Science: Women Physicians in American Medicine*, Oxford University Press, 1985, \$24.95.

Are women doctors different from men doctors? Or are they essentially similar in their ability to practice medicine? Tracing women in the medical profession from the colonial period to the present, the author places this controversy in its historical context.

Essays by **Regina (Markell) Morantz-Sanchez '65** and others, "*Send Us a Lady Physician*": *Women Doctors in America, 1835-1920*, edited by Ruth J. Abram, W.W. Norton, 1985, \$20/\$12.95.

In the second half of the nineteenth century women began entering the medical profession, from which they had previously been barred. This book focuses on the class of 1879 at the Woman's Medical College of Pennsylvania and presents in text and photographs an important period in women's history.

**Anne Attura Paolucci '47**, *Sepia Tones: Seven Short Stories*, Rimu Publishing, 1985, \$10.

Italian-American experience in the 20th century is the common theme of these seven varied stories. With lively dialog and characters.

**Abby (Glazer) Robinson '70**, *The Dick and Jane*, Delacorte Press, 1985, \$14.95.

Wisecracking and gum-snapping from page one, photographer Jane Meyers teams up with P.I. Nick Palladino to solve the case of a hostile cult, and the result is a fast-paced, satirical romp through this first novel.

**Jane Schwartz '70**, *Caught*, Ballantine, 1985, \$5.95.

The special friendship between a ten-year-old and a grown man and their passion for pigeon-flying form the basis of this endearing book.

**Mala (Weltsman) Tabory '69**, *The Multinational Force and Observers in the Sinai: Organization, Structure, and Function*, Westview Press, 1986, \$19.50.

This is a thorough description of the origins of "the first modern multinational peacekeeping force that is independent of any organization," complete with the text of the 1979 Egyptian-Israeli Peace Treaty and maps.

## Performances

**Laurie Anderson '69** and **Suzanne Vega '81** wrote lyrics for parts of "Songs From Liquid Days," composed by Philip Glass, which can be heard on a CBS Masterworks record of that name.

**Pat Cremins '83**, choreographer, and **Rhonda Rubinson '80**, director, were singled out for praise in *The New York Times* review of John Cage's "The Bus to Stockport and Other Stories." The operatic event, which took place in the Minor Latham Playhouse in February, was part of the Opera Uptown series; Mr. Cage was a Gildersleeve Lecturer.

"**Sally Hess ('62) Solo Dances**," all choreographed and performed by her, were presented at the Dunn Studio, NYC, in January. *The New York Times* called one of the pieces "an intellectual tour de force that glows with humanity."

"The Tale of Madame Zora," a biographical musical about **Zora Neale Hurston '28**, opened in March at the Ensemble Studio Theater on West 52nd Street in New York City.

Short stories by **Zora Neale Hurston '28** and **Lynne Sharon Schwartz '59** were read in a program of "Selected Shorts" at Symphony Space, NYC, in May.



**Susan Jacobson ('81)** & Dancers performed at the Middle Collegiate Church, NYC, in February. Susan will give a dance performance at Reunion on Friday afternoon.

Pianist **Rebecca Pechefsky '85** performed pieces by Schubert, Brahms and Borodin in a program with the Amici String Quartet at Casa Italiana in March.

In February and March, composer **Faye-Ellen Silverman '68** presented three world premieres: "Passing Fancies" at the Los Angeles County Museum of Art, "Restless Winds" at Merkin Concert Hall in NYC, and "Stirrings" at Johns Hopkins University.

Composer **Jeanne Walsh Singer '44** won three prizes from the Composers & Songwriters International, in the vocal solo, choral, and instrumental categories. The honors were announced in December. She also had four works performed at the New York Public Library at Lincoln Center in December; cellist **Elizabeth (Dykema) Sadewhite '70** was among the musicians.

## Exhibits

Works by **Louise (Heublein) McCagg '59**, her daughter Alexandra, **Kristi Pfister '78** and three others formed "Drawings: One To Six," an exhibition shown in March and April at LEDO, a New York City gallery run by **Joyceann Yaccarino '82**.

**Annie Kirkpatrick Nisbet '82** exhibited her paintings, prints and hand-made papers in a one-person show entitled "Transitions" at Teachers College in April.

Watercolor, acrylic and oil paintings by **Mary Paul (Sandy) Segard Rice '37** were exhibited in her hometown of Hot Spring Village, Arkansas, last November and December.

Recent paintings by **Deborah Rosenthal '71** were exhibited in her first one-person show, at the Bowery Gallery, NYC, in February.

Works of art by **Caroline Prieur Schulz '76** and 17 other Columbia-related artists were shown on campus at Low Library during March.

**Joyceann Yaccarino '82** was one of nine artists whose works were exhibited at the Bogues-Messinger-Rangel Gallery, NYC, during January.

## Wanted: News of the Muse

Good news travels fast, but someone has to get it started. We'd like to publish more, and more current, notices of alumnae concerts, recitals, readings, films, exhibits, etc., as well as books, but we depend on you to tell us about them. Send advance notice of your presentations and publications to *Barnard Alumnae Magazine*, 3009 Broadway, NY, NY 10027-6598.

## Seminars for Home Study

The Associate Alumnae presents the faculty of Barnard College in a series of courses for home study. Each course includes a syllabus, audio-cassette tape with commentary by the professor, a set of books for primary reading, and supplementary reading texts.

### I. JUDAISM IN THE TIME OF JESUS

*Alan Segal, Professor of Religion*

An introduction to the Hellenistic period in Jewish history as the cradle out of which both rabbinic Judaism and Christianity arose. The basic issue is how two religions so different today could have come from the same background.

### II. THE BODY IN MODERN THOUGHT

*Maire Jaanus, Professor of English*

Major discourses on corporeality, its structure, function, power, pleasure, limits, and drives; its oneiric and symptomatic language. Included in the reading are Nietzsche, Merleau-Ponty, Foucault, Freud, and Lacan.

### III. DON QUIXOTE

*Amelia Agostini de del Rio, Professor Emerita of Spanish*

In this study, we will develop two themes: 1) the antithesis in Don Quixote, perhaps the literary device most used by Cervantes, and 2) the technique and style, with stress on the dialogue. The course will serve as a refresher for those who have read Cervantes and will also provide an introduction for those who are coming to his work for the first time.

### IV. DANTE'S WORLD

*Maristella Lorch, Professor of Italian*

A literary analysis of selected topics in the *Divine Comedy*—death, love, and justice—placed in the context of the political and social developments and theological currents of the 13th and 14th centuries.

### V. FIVE WESTERN COSMOLOGIES

*Frederick G. Peters, former Assistant Professor of German*

The study of cosmology as a structure of meaning that offers man a framework for his experience of the world. Readings include the *Old Testament*, Homer's *Odyssey*, Dante's *Divine Comedy*, Goethe's *Faust*, and Kafka's *The Castle*.

### VI. ORIENTAL ENCOUNTERS: THE AMERICAN EXPERIENCE

*Barbara Stoler Miller, Professor of Oriental Studies*

Readings introduce the works of prominent American writers whose encounter with Oriental culture had a significant effect on their literary expression and helped in the formation of American attitudes to that culture.

### COMING SOON: AN INTERDISCIPLINARY COURSE IN WOMEN'S STUDIES

*Professors Suzanne Wemple (History), Nancy Miller (Women's Studies), Leslie Calman (Political Science), Julie Doron (Psychology), Helene Foley (Classics), and Celeste Schenck (English)*

This exciting program, dedicated to the memory of Professor Annette Baxter, will include tapes and readings on women in antiquity and the early Middle Ages, feminist literary theory, mothers and daughters in literature, and contemporary feminist ideology and psychology. Watch for details in our Summer issue—do not order this course at this time.

All inquiries and orders should be sent to the Office of Alumnae Affairs, 3009 Broadway, New York, NY 10027-6598. Cost \$40 per course. Please make checks payable to Barnard College.

# IN MEMORIAM

- 09 Helen McPherson, July 29, 1985  
 10 Adelaide Loehrsen, January 29  
 Elfrida Cowen Solis-Cohen, 1985  
 11 Emilie Bruning, December 17, 1985  
 13 Jean Townley Leich, January 22  
 15 Annie Fuller Kuever, 1983  
 16 Louise Talbot Seeley, January 26  
 17 Dorothy Bryan, September 12, 1984  
 Beatrice Walker Cullison, February 1  
 18 Marjorie Nichols, February 8  
 19 Rose Le Vino McKee, December 3, 1985  
 Dorothy Hall Morris, December 6, 1985  
 20 Marjorie S. Kydd, 1985  
 22 Louise Rissland Seager, August 1, 1985  
 24 Ethel Allen Scott, April 14, 1985  
 26 Marian Meade Champlin,  
 November 1, 1985  
 28 Margaret Stanley Dykstra,  
 November 7, 1985  
 30 Betty Drury, March 1  
 Sylvia Jaffin Liese, March 2  
 Jeanette White, January 27  
 31 Mary Keith Newell, November 8, 1985  
 34 Mary Phelps, March 26, 1985  
 36 Jacqueline Hayes Ardoin,  
 November 7, 1985  
 37 Harriet McClure Heald,  
 December 26, 1985  
 40 Audrey Blair MacKin, October 21, 1985  
 Frances Dinsmoor Sandstone, July 1, 1985  
 44 Ann Rosensweig Klein, February 23  
 45 Jean Walden Riker, April 1984  
 51 Nancy Van Arsdell Campbell, January 4  
 53 Lois Wersba Roth, January 13  
 56 Loretta Lambert Leive, February 12  
 Linda Nison Murray, February 3  
 64 Doris Seiler Heyman, January 19  
 69 Ann Newman, January 8

## Romola Lyon Lyons '04

We note with sadness the passing last year of Romola Lyons. She had two daughters and then entered Columbia P&S, graduating in 1929. She interned in Englewood Hospital and practiced medicine, especially dermatology, for some time. She kept in touch with many of her classmates and friends until a short time before her death.

A. Louise Brush, M.D. '25, P&S '29

## Richard P. Youtz

Except for a year at another college and a period of service in the U.S. Air Force, Dick Youtz was a member of the Barnard faculty from 1937 until his death this past February. In 1940 he taught the college's first course in psychology and second course in which students conducted their own independent research. He served as chairman of the Psychology Department from 1946 until 1974, and the courses we offer today are, in large part, direct descendants of the curriculum that he worked to create.

An experimentalist who believed that people learn by doing, he instituted lab courses in seven sub-areas of psychology and arranged for a field work course at the Payne Whitney Psychiatric Institute. Later on, he provided the support to create the Barnard Toddler Center so that students could have first-hand field research experiences right on campus. His course on teaching students to design experiments by analyzing case studies was introduced in 1960 and refined for 24 years. In that process he created a textbook on the design of experiments which will be published posthumously.

No phenomenon seemed to Dick Youtz too far out to approach scientifically. He spent three years studying the perception of colors through the skin, and his scientific approach brought rationality to a sometimes wild discussion that was taking place in the popular press.

After his retirement from the Psychology department in 1975, Professor Youtz joined the Office of the Dean of Studies, first as a class adviser and in 1979 as Director of Resumed Education. His sensitivity, good humor, and commitment were often the critical factor in the success of his students.

Prof. Peter Balsam

Chairman, Dept. of Psychology

## Gladys Meyer

Gladys Meyer's earliest interest was theatre, and when she graduated from Wellesley in 1930 she had already worked for a year with Eva LeGalliene's Civic Repertory Theatre and had a play produced there. She received a fellowship to study in Germany, where her interest shifted to sociology, and she returned to Columbia to earn her Ph.D. She taught first at Vassar, then went to the Columbia School of Social Work, and came to Barnard in 1948. In 1957, while on sabbatical, she was a consultant to the United Parents Associations in implementing the first plans for busing of New York City public school students to achieve racial balance. After her

retirement from Barnard in 1974, she taught at Bard College.

Professor Meyer was the author of "The Urban Pattern of Success" in *Benjamin Franklin and the American Character*, *Free Trade in Ideas*, *Parent Action in School Integration: A New York Experience*, and many articles and government reports. She was co-author of the textbook *Minorities in American Society*, soon to be published in its sixth edition, on which she was working up until her death this past January. Her novel *The Magic Circle*, relating her experiences in Germany before WWII, was published by Knopf in 1944.

She is survived by a daughter and two sons.

Mirra Komarovsky '26  
 Professor Emeritus

## Ann Rosensweig Klein '44

She was "a politician in the best sense of the word," according to a major New Jersey newspaper, "courageous, outspoken, and kind." A graduate of the Columbia School of Social Work, former president of the League of Women Voters of New Jersey and member of the State Assembly, Ann Klein was the first woman in her state to mount a serious campaign for governor. She finished second to Brendan Byrne in the 1973 Democratic primary and was then appointed to be Commissioner of the Department of Institutions and Agencies. When that department was reorganized, she became Commissioner of Human Services, playing an important role in the administration of evolving social policy. She also served as an administrative law judge in Newark.

Ann Klein died in February after a long battle against cancer.

## Sylvia Jaffin Liese '30

When Sylvia Liese was appointed judge in the NYC Domestic Relations Court in 1955, the *New York Times* said it was the best court appointment Mayor Robert Wagner ever made. She had graduated first in her class at Columbia Law School and had been an Assistant District Attorney in NY County, and on the bench she worked for the creation of the Family Court so that children could be better served. One of her most important legacies was her successful effort, along with Eleanor Roosevelt and Justine Wise Polier '24, in establishing the Wiltwyck School for Boys. Ill health forced her retirement and subsequent relocation to Tucson, where she and her husband became active in the Jewish community. In 1974 she suffered a massive stroke that left her unable to talk or walk, but two things were absolutely unaffected: her fine intellect and her zest for life. She will be sorely missed.

Billie Herman Kozolchik '60

# CLASS NOTES

## 10 Alumnae Office

We were sorry to learn that **Adelaide Loehrsen** passed away at her home on the Upper West Side of Manhattan on January 29. She would have been 99 years old in May. A memorial service was held in Riverside Church. We extend our sincere sympathy to her family and friends.

**12 Lucile Mordecai Lebair**  
180 West 58th Street  
New York, NY 10019

**13 Mary Voyse**  
545 Asharoken Avenue  
Northport, NY 11768

**14 Edith Mulhall Achilles**  
570 Park Avenue  
New York, NY 10021

**17 Elizabeth Man Sarcka**  
51-01 39th Avenue, W26  
Long Island City, NY 11104

**Sara Lewin Diska** is happy to have her granddaughter Sara staying with her and distinguishing herself as a student at Parsons School of Design. Young Sara met **Elizabeth Man Sarcka** for lunch at the Metropolitan Museum of Art in January. Elizabeth, who always uses a wheelchair for museum viewing, somehow drove her wheelchair down an unseen flight of five stairs and broke her hand. Now she is living with her daughter Anne in Montpelier,

Vermont until her hand is usable.

We were sad to learn of the death of **Beatrice Walker Cullison**, in a letter from her granddaughter. We extend our sympathy to her family.

## 19 Alumnae Office

We extend our sincere sympathy to **Dorothy Brockway Osborne** on the death last December of her husband, Harold S. Osborne. He was for many years chief engineer at AT&T. After retirement he served as president of the Regional Plan Association, and was mayor of Montclair, NJ from 1961 to 1964.

**20 Granville M. Snyder**  
R 1, Box 158  
Yorktown Heights, NY 10598

**21 Helen Jones Griffin**  
3030 Park Ave., Suite 6N8  
Bridgeport, CT 06604

**22 Agnes Bennet Murphy**  
40 Riverside Avenue  
Red Bank, NJ 07701

Here we are in 1986—and aren't we surprised! When I saw Halley's Comet in 1910, I wondered whether I would ever see it again. Well, in early December, a friend set up a telescope by the house in Little Silver, and there, below Pegasus, was a very small blur, a very subdued Halley's Comet showing

no tail. Hope you saw it too.

**Dorothy Berry Davidson**, early in December, had the experience of having an automobile crash into her living room, car out of control, radiator spouting dirty water over everything. No one was injured, but what a bad surprise.

**Elsie Garfunkel Gottesman** managed to get to New York (from Los Angeles) to greet her new great-grandson, a thrill for all, as it is the first baby in the family in over twenty years. All her great-grandchildren are very interesting young people, she says, lawyers, editors, and electrical engineers.

**Lucy Olga Lewton** sent news of another book she wrote, *Some Firsts and Lasts: A Baker's Dozen of Memories from an Uneventful Life*. She was planning in January to move to an apartment on a lower floor, "as I can't stand the fire drills, climbing down six flights of stairs."

A number of classmates send greetings to all of you. **Eleanore Starke Frank**, **Edith Heymann Riegel**—Happy New Year.

**Alice Peterson Brown**—Greetings to all our tough survivors.

**Helen Frankenstein Shoenfeld**—Every good wish for a Happy and Healthy 1986 and **Isobel Strang Cooper** the same.

Several people helped in sending out holiday cards, including **Noreen Lahiff Grey**, **Adele Henry Miller**, and **Donah B. Lithauer**.

**Natalie Gorton Humphrey's** present address is Hanover Hall, 267 Frederick St., Hanover, PA 17331. Her daughter-in-law Constance Humphrey writes that more than two years ago, Natalie suffered a massive stroke. She remains bedridden and paralyzed and rarely speaks. This is very sad news.

The next item is also sad news. I have been notified of the death, last August, of **Louise Rissland Seager**.

**23 Charlotte MacNamara Guedalia**  
816 Seneca Road  
Great Falls, VA 22066

**24 Mary Pyle Fleck**  
3758 Collins Street  
Sarasota, FL 33582

It is my sad duty to report the death of another classmate. The death of **Ethel Allen Scott** occurred April 14, 1985. We send sympathy to members of her family.

**25 Helen Kammerer Cunningham**  
574 Yorktown Road  
Union, NJ 07083

The life of Class Secretary is a bit trying. You meet the deadline for the Winter issue and sit back and relax. Before you know it notice arrives that the Spring contribution is due and you not only have no news but what you sent in last has not yet appeared in print. But you start again calling everyone, begging for more news.

First victim, **Margaret Melosh Rusch**. "Oh no," says Peg, "I haven't done anything interesting." But

## ALUMNAE RECORDS CORNER

CAN YOU HELP? We have incomplete documentation on the deaths of the alumnae listed below. If you can corroborate the information or know the date of death, or are the living proof that our information is in error, we would appreciate hearing from you.

Bertha Bayer '25  
Frances Goldstein Brichto '61  
Mildred Ryan Brim '24  
Gertrude A. Cooke '21  
Gladys Berry Cooper '24  
Isabel N. Gaebelein '41  
Dorothy Gould Graves '25  
Livia Shero Hines '25  
Betty Shoor Klein '30  
Audrey Blair MacKin '40  
Mary M. Murphy '18

Estelle Wasserman Plaut '15  
Alice Mendham Powell '25  
Malissa Childs Redfield '50  
Margaret C. Reinke '24  
Freda Wacht Schiff '25  
Charlotte Doscher Stephens '52  
M. Hilarion Doyle Swift '24  
Marjorie Ruter True '33  
Helen Manz Watzik '28  
Patricia Castle Welsh '65

Information should be sent to Records Management Officer, 221 Milbank, 3009 Broadway, New York, NY 10027-6598.

after a little chatting I find that she is a trustee of the Seabury Memorial Home, the YMCA, and the Community Church of Mt. Vernon, and program chairman for several organizations. Sounds like a busy life to me.

Next victim, **Marion Kahn Kahn**. "No, I have no news. You caught me just as I am about to leave for Florida." But in our chat I learned that Marion went to Europe last year, visiting four countries behind the Iron Curtain. Recently she and Anne Gintell took a trip to Washington, DC.

Next victim, **Anne Leerburger Gintell**. Anne spoke of the Washington trip, especially the exhibit of objects from British houses, and the very impressive State Department diplomatic offices. She was especially impressed by the Vietnam War Memorial. Anne is an officer of the League of Women Voters in New York City, and a duplicate bridge player.

Someone said, "Call **Estelle Blanc Orteig**. She has been doing lovely oil paintings and has had them in shows." I called Estelle. Yes, she had some of her work on display right then in a group show at the Fabrizio Art Gallery. She usually works in oils but was planning to do some watercolors when she went to Palm Beach Shores, Florida a few weeks later.

In a call to **Marion Mettler Warner** I learned that she is in touch with several class members who, like herself, live in Heritage Village, Southbury, Connecticut. She spoke of **Elizabeth Webster Link**, our June 1985 bride. Betty and her husband are in Florida and will be returning to make their home in Heritage Village.

**Sylvia Valenstein Newfield** is also a resident of the Village. A note from Sylvia says, "Still here and still coping. Keeping busy." Marion says Sylvia is known for her paintings — watercolors and acrylics.

**Pearl Bernstein Max**, our president, **Madeleine Hooke Rice**, our honorary president, **Marion Kahn Kahn**, our Fund chairman, and **Emma Dietz Stecher**, our treasurer, met recently for lunch and to talk over a class letter concerning fundraising. I heard by the grapevine that a spring class tea was also mentioned.

Pearl is active in New York City affairs. She is a member of the Education Committee of the Women's City Club of New York. They are concerned with city government, education, housing, etc. Members of the committee include people professionally active in the field, retired people, many minorities.

Classmates, most of us are not active in city government or League of Women Voters committees, etc., but we are interested. We are especially pleased to hear about old friends and know that they are still active. Your classmates would like to hear that you are still around. Please send news and greetings. Just tell us what you are doing.

I want to thank **Dorothy Putney** for her help with this column. Dot is an unending source of information. She seems to keep in touch with everyone. She is always ready to guide me to possible news.

**26** **Eleanor Antell Virgil**  
Pennswood Village, Apt. K110  
Newtown, PA 18940

**Mirra Komarovsky**, professor emerita and special lecturer in sociology at Barnard, was awarded a grant from the National Science Foundation for 1986-87 for a research study in the sociology of knowledge.

**27** **Mildred Gluck Tomback**  
88 Lake Shore Drive  
Eastchester, NY 10709

Although this news arrives a little late, it is still pertinent to my constant request for "news"!!

**Roslyn Schiff Silver** informs us that her husband, Julius, established in October 1984 the Silver Profes-

sorship for Law, Science and Technology at Columbia Law School. Roslyn and her husband live in Greenwich, Conn.

**Janice Moses Sullivan**, whose husband died last November, 1985, lives at 400 Seasage Drive, Delray Beach, Florida.

**Clarice Philhower Beam** writes the following from her home in Millinocket, Maine:

"I join my classmates who are suffering from problems of poor vision. Macular degeneracy makes it impossible for me to drive. In the country, where no public transportation is available, this is hard. I do manage to read with the help of a magnifying glass but the progress is slow. I'm happy to keep up as best as I can."

We have been informed of the death of **Mabel Walker** on October 10, 1985.

**28** **Eleanor Michelfelder**  
445 Gramatan Avenue  
Mount Vernon, NY 10552

**29** **Anny Birnbaum Brieger**  
120 East 81 Street, Apt. 10A  
New York, NY 10028

**Olive Bushnell Morris**  
20 Ellsworth Street  
Rye, NY 10580

It happened 60 years ago in April 1926. We quote from the *New York Herald Tribune* report printed the following day: "The Freshman class of Barnard College, Columbia University, triumphed yesterday over the Sophomores in 'Greek Games,' Barnard's annual classic contest in drama, poetry, music, dancing, costume and athletics. It was the second victory for a Freshman class in the 23 years that the games have been held. The class of '29 took the lead in the entrance dramatization . . . and kept it 'till the end.'"

Does anyone remember who the astute judges were whose decisions made 1929 a winner by the slim margin of 51.3 points out of 100? They included such well-known persons as Norman Bel Geddes, scene designer; John Erskine, Columbia professor, author and musician; Tony Sarg, marionette maker and craftsman; Edwin Markham, poet; and Brander Matthews, professor of dramatic literature at Columbia.

So much for the past. We bring it up only to remind ourselves that the Class of 1929 was remarkable from the beginning. Now for the present.

Volunteer work, taken up or continued after retirement, keeps most of our classmates busy.

**Matilda Sommerfield Miller** has retired after 18 years as a counselor at SUNY-Farmingdale, but continues to work part-time on a new venture. She conducts a Basic Wang Word-Processing Workshop for senior citizens at SUNY. This training course prepares senior citizens to compete in the job market for positions requiring skills in word-processing.

**Bessie Bergner Sherman** keeps busy in a half-dozen volunteer activities. A special interest of hers is making the rounds of art openings in and around her home in Bridgeport, and from time to time at the Whitney, Metropolitan and MOMA in NY City.

In spite of some physical limitations that curb her activities, **Georgiana Volze Bishop** reports that she is enjoying her old age and continues to support causes that she believes in, especially the nuclear freeze movement and Planned Parenthood.

**Evelyn Atkinson Ehrman** has retired from the Washington, DC public school system after many years as a school psychologist. She also had worked for 11 years as a volunteer with the Epilepsy Foundation for the Capitol area.

**Margaret Burford Stephany** takes a keen interest in politics, and when visiting her daughter in Maryland attends House and Senate hearings in Washington. She especially endorses the fight against protectionism and supports measures to preserve the country's environment.

**Edith I. Spivack** has been appointed to the Columbia Law School committee to choose the reci-

ipient of the Medal for Excellence. She also serves on the Judiciary Committee of the New York State Bar Association and on the Women's Rights Committee of the New York County Lawyers' Association.

—OBM

**30** **Helen Chamberlain Josefsberg**  
45 Sussex Road  
Tenafly, NJ 07670

**Grace Reining Updegrove**  
1076 Sussex Road  
Teaneck, NJ 07666

**Viola Robinson Isaacs** writes: "1985 was another special year for us. Harold and I had the great joy of celebrating our 75th birthdays with our entire family—children, in-law children, and six grandchildren, all now living in the US after many years abroad for both families. Earlier in the year, at the invitation of *China Daily*, an English language paper published in Beijing, and the China Journalists Association, I spent three weeks in China with a group of 'old China hands,' i.e., people who had lived in China before 1949. Some of the group were old friends from the '30s; others had been in China during World War II. This was my second visit since we left in 1935. Harold and I had returned in 1980 at the invitation of the Chinese Writers Association for a visit to old friends and places. Our experience of that return and our impressions are preserved in a book entitled *Re-Encounters in China: Notes of a Journey in a Time Capsule* by Harold R. Isaacs (published by M.E. Sharpe, Armonk, NY, 1985).

"Unfortunately, for reasons of health, Harold could not make the journey this time, but he insisted that I join the group. Reluctantly I agreed, and as it turned out I was very glad I did. We were greeted as 'old friends of China' and given very special treatment, including a long interview with Deng Hsiao-ping. We traveled to the west in a private plane to Sian and Chungking, seeing the splendors of the past and the changes in the countryside. Everywhere we were greeted and briefed by officials, shown through factories, markets, peasants' homes. We sailed down the Yangtze through spectacular gorges, visited with students at Hankow University, and watched the building of a great dam across the Yangtze, which will someday not only provide enormous quantities of electric power but also raise the level of the upper river to change the contours of the gorges permanently. We visited industrial complexes and many different factories, glimpsing some of the changes involved in 'modernization.'

"It was a varied and most interesting time, filled with much conversation with our hosts and young interpreters, ending in Shanghai where my China adventure began so many years ago. There are many weighty things that might be said about what is happening in China, and where things are going, but I shall leave that to others. For me this journey was a very personal one, an overlay of past and present, in many ways a visit to my youth."

**Marian Irish** is continuing her yearly explorations. In 1985 she reached Samarkand, Bukhara and Tashkent.

"Cats" in London, rain and snow in St. Albans—this was March '85, when **Betty Drury** and Marvin Clapp went to England to celebrate their 51st wedding anniversary and see old friends. Then in late summer they had several weeks of sunshine and color in Bermuda—surely the world's prettiest place, according to Betty, and only an hour and a half from New Jersey by plane!

**Mildred Sheppard** enjoys hearing from us, although she is not always able to reply. She is at the Sharon Nursing Home, 18201 Marden Lane, Olney, MD 20832.

Let's not wait for a major reunion to return to Barnard on Alumnae Days. They are always well planned.

On behalf of the Class of 1930 we extend our deep sympathy to the families and friends of **Sarah Elizabeth Rodger Moore**, **Virginia Simkins** and **Jeanette White**.

**Harriet Brown Total** reports she is still traveling: Midwest and Pacific coast in September and Charlotte, NC for Christmas and New Year. She plans another trip to Europe next summer.

**Elisabeth Raymond Heiss** became a grandmother for the fifth time; Alana Kathryn Heiss was born in Rochester, NY.

**Marjorie Nichols Boone** is fund raising chairman of the Sun City Fine Arts Society and serves as a member of the Grants Panel of the Arizona Commission on the Arts and of Volunteer Development for Older Adult Resources in Phoenix.

**Isa McIlwraith Plettner** has been elected president of the Chattanooga Torch Club, the first time a woman has attained that position. The club is a member of the International Assn. of Torch Clubs Inc. The local club's membership of 55 consists of professional individuals — doctors, lawyers, clergymen, university professors, architects, scientists and others — who meet once a month for dinner, followed by a talk presented by one of the members. Its purpose is to offer a place for kindred spirits in the various professions to get together for a friendly meal and the exchange of ideas. They also publish a quarterly magazine containing the speeches voted best for that quarter from the various clubs in the organization. Five years ago, Isa's husband, Dr. Arthur Plettner, was the president of the Chattanooga Torch Club.

**Marion Shipley McCabe** of San Diego wrote, "I expect to be present at our 55th Reunion." We hope many of you plan to be there for this important event, on May 16 and 17.

We received a friendly note from **Edith Tarbes Gellert** down South: "Perce and I are at our winter home in Hallandale, FL until mid-April. We are in the Broward phone book. Our eldest granddaughter is at Tufts U for her master's in arts and education. She graduated from Amherst College. Her brother Robert is a junior at Amherst and will take the second semester at Reid Hall in Paris. Our youngest is a senior at White Plains High School."

**Madeleine Stern** writes that she is co-editing *The Selected Letters of Louisa May Alcott* for publication by Little, Brown in 1987. Her co-editors are Prof. Joel Myerson of the University of South Carolina and Dr. Daniel Shealy of Clemson University.

With our 55th Reunion (May 1987) only one short year away, a letter from each member of the class with news of your family and of your own current activities will be most welcome. Write promptly, please, lest old acquaintance be forgot.

Our very deep sympathy is expressed to **Adele Burcher Greeff** on the loss of her brother William Montgomery Burcher, who died on Jan. 2 in the Netherlands Antilles.

**Eileen Kelly Hughes** spent two weeks with **Muriel Kelly Major** on Long Island and at Lake George. Thanksgiving weekend was spent in Fort Lauderdale with the whole Major family. From March 11-22, Muriel enjoyed a trip to the Holy Land and was looking forward to taking in the "Journeys of Paul" in the near future.

**Margaret Martin** was still trying to raise money for the Statistical Association. She bought a personal computer to write a policies and procedures manual. As of spring '85, she was mid-way into the 4th of 18 lessons on the word processor.

**Elizabeth B. Barber** said she had no plans to retire. She has been volunteering at two hospitals and at one she had well over 1000 hours to her credit. In May '85, she was planning to visit London and also spend one day at Canterbury, especially at the cathedral. Then, in August '85, she was scheduled for a group trip from the Cathedral of St. John the Divine of NYC.

**Martha Loewenstein** left for Israel and Europe on April 2 and returned on June 11. **Laura Smith Lomo** was out-going VP for programs of the AAUW of Northwest Bergen and then became editor of "The Garden Statement," a publication of AAUW. Besides being an active member of AAUW, she was finding her computer with word processing capabilities endlessly entrancing.

**Sylvia Thomas** went to Egypt for a Nile cruise in Feb. TWA sent her to Cairo and her luggage to Munich. She acquired an Egyptian wardrobe for five days of the cruise until she got her luggage back. She said TWA paid and apologized. **Isabel Roberts** could not get up to NYC for the mini-reunion because she had been laid up for four months with a broken hip and had a tremendous backlog of work.

**Mildred Wurthmann Ruffner** and her husband have enjoyed ten years of retirement and were finding themselves slowing down. They still love to travel as do their children. Their son, a commercial attache, has been posted in Amsterdam and their daughter had recently moved to London on an IBM assignment.

**Anna Sardi Gina** wrote last March that she and her husband were planning to spend May '85 in Normandy, Brittany and Vance. Their grandchild Michael Levitt arrived on Feb. 9, '85. His sister Jennifer Anne, born in Dec. '83, already seems Barnard material.

**Iva Ellis MacLennan** and **Julia McNeely Vance** enjoyed the 50th Reunion but Iva could not attend the mini-reunion because she and her husband spend the summer at their cottage on Baptiste Lake in Ontario.

Catching up on the past activities and travels of '33, we pass on the following news just as it comes off the top of the pile as forwarded by Fran Barry in the responses to the mini-reunion on March 17, 1985. **Mildred Pearson Horowitz** enjoyed an unusual trip with the Jewish Museum to Prague and Budapest last fall. Life in Prague was stark and difficult. Budapest was gay and very cosmopolitan, but the "Blue Danube" is not blue.

**Catherine Crook De Camp** wrote that for people past their late youth, the De Camps just go right on working and lecturing to the science fiction and fantasy readers. **Jean Waterman Bender** and her husband were appreciating leisure time more and more and looked forward to a lengthy trip to some new parts of the world in the near future. They have six grandchildren, with the 7th expected in May.

In a letter received at the Alumnae Office last December **Alice Kish Winter** reported that she has renewed her avocation of sketching and painting. Her work was shown in a studio show last November, and in February in another show there were 25 of her sketches as well as two oil paintings.

A note from **Mildred Mangelsdorff Elsner** relates that she and her husband, Curt, spent six weeks last fall touring Belgium, Germany, Holland, England and Scotland.

**Esther Merrill Wise** is a very busy volunteer. She is president of the Atlantic City Day Nursery, vice president of the Retired Educators Association of Atlantic County, and a trustee of the "Save Lucy Committee" which is renovating the Margate

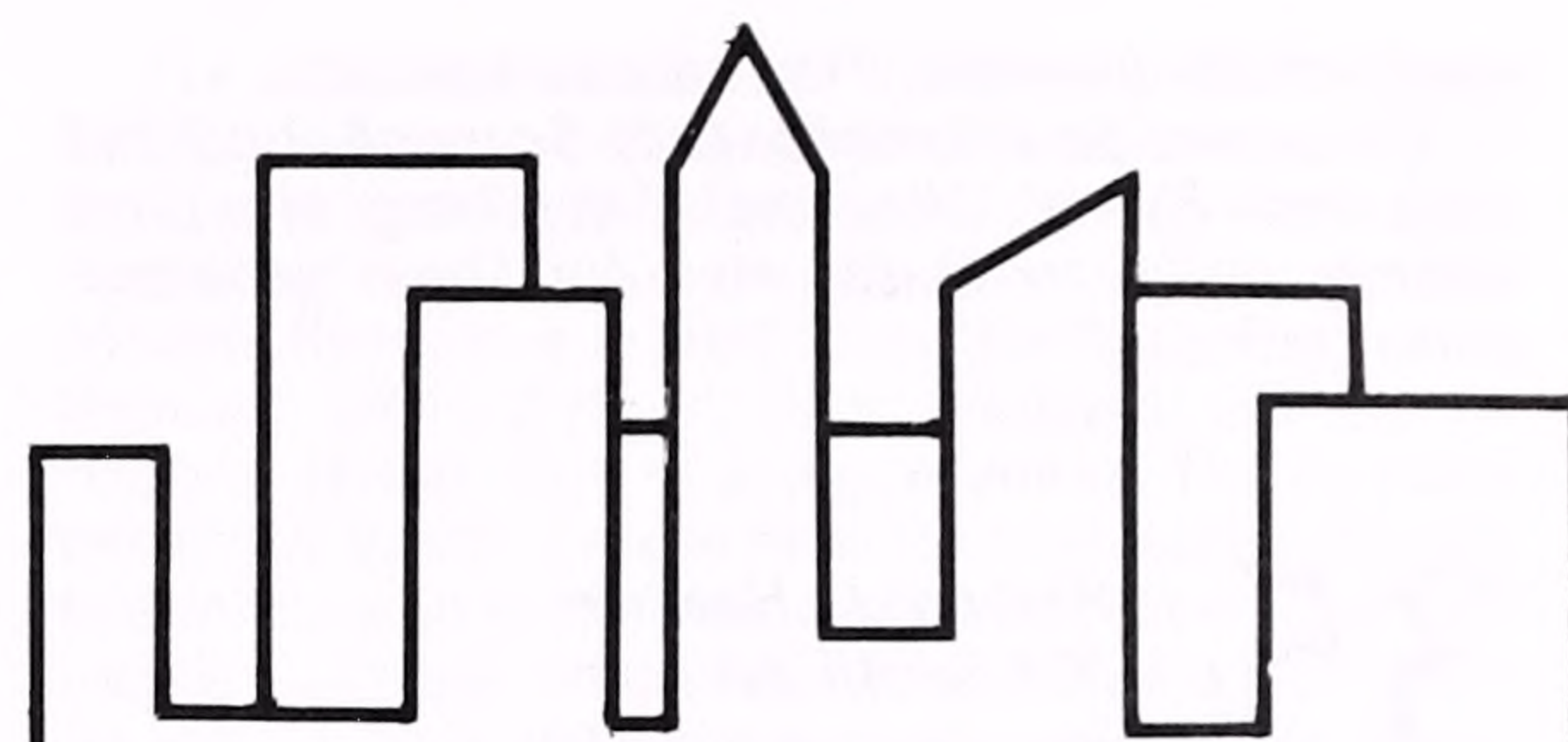

## CAMPUS CALENDAR

Alumnae College  
May 18-22

Alumnae Travel Program  
to Russia  
June 10-25

"Summer in New York"  
Pre-College Program  
July 6-August 2

First Day of Classes  
September 8

Alumnae Council  
October 31-November 1

Translation Conference  
November 7-9

Graduation  
May 13, 1987

Reunion  
May 15-16, 1987

For up-to-the-minute information about on-campus events, call the College Activities "24-hour hot line," 212-280-2096.

Class Notes deadlines:

Fall issue	August 22
Winter	November 14
Spring	February 13, 1987
Summer	May 13 (Non-Reunion Classes) May 22 (Reunion Classes only)

elephant. She writes, "Come take a tour."

Class president **Gertrude Lally Scannell** and Fund chairman **Sylvia Weinstock Weinberg** are busy writing notes to classmates for their generous contributions.

**35** **Kathryn L. Heavey**  
238 Smith Avenue  
Kingston, NY 12401

Notes and greetings during the holiday season came in from **Carolyn Prager Moyer**, **Eleanor Schmidt** (remarking that her attitude toward alumnae on campus has changed since college days when she thought the campus should belong to students), **Elise Cobb Balsam**, **Mary Goodson Lih**, **St. Clair Baumgartner Craighill**, **Marion Meurlin Gregory**, **Gertrude Rubsamen Brooks**, **Marjorie Kimont Lathrop**, **Elizabeth Simpson Wehle**, **Nancy Crowell Hendrick**, **Mary Gertrude Donovan Meyer**, **Betty Lulince Rolnick**, **Mildred Fishman Stein**, and **Dora Jane Rudolf Buchli** (all the way from Switzerland).

Christmas in Florida turned out to be colder than New York for **Ruth Bedford McDaniel**, but the warmth of staying with relatives and her son flying over from California made up for the 19° temperature.

**Edith Cantor Morrison's** note made me a little envious—a tour of Egypt with her 18 year old granddaughter, a trip to China, a relaxing visit with her daughter and family in Orlando where a granddaughter is one of the University of Florida Madrigal Singers and they serenaded Edith. At writing, she anticipated beginning 1986 in Albuquerque, NM and ballooning with other family members.

**Vivian Tenney** again managed to cover at least half the globe, from the temples, pyramids and towns of ancient Yucatan cultures to watching the sun rise over the sea from the terrace of the Sheraton Waikiki Hotel where she combined business at morning medical meetings with the pleasure of visiting friends and sightseeing afternoons.

If anyone from '35 is going on the Barnard tour to Russia, send us a postcard—if you have time to get a card and stamps!

**36** **Vivian H. Neale**  
102 Forty Acre Mountain Rd.  
Danbury, CT 06811

A personal reward for "networking for Reunion" is the communication, direct or indirect, with so many '36ers. The responses to requests for support and to the long questionnaire have been, in a word, wonderful, thanks to the efforts of networkers from Maine to Florida, from New York to California and over the waters. **Marjorie Runne Allen**, our "foreign correspondent," received a warm letter from **Anne Henry-Labordere**, who was at Barnard our senior year as an exchange student from France. Anne recalled happy memories of her year here and lasting friendships made. She expressed good wishes to all for a successful Reunion and said she would be very pleased to have Barnardites contact her when they are in Paris.

**Florence Ribakove Bar Ilan**, in Israel, is an example of people who do not retire upon retirement. Having left teaching English at the secondary school level, she now works part-time teaching language proficiency for elementary school teachers who want to teach at the junior high school level. She is also supervising high school teachers studying for their teaching certificates. And she plans to be at Reunion!

More detailed news of Anne, Florence and other distant classmates can be shared by all—those who come to Reunion and those who are unable to come—through the booklet that will be in print for our big occasion.

Through our request for word of "lost" classmates we have found **Gertrude Maureen Donovan O'Brien** alive and well and living in New Jersey. We anticipate seeing her at Reunion.

So, come! Join your classmates in celebrating Fifty Years of Life After Barnard. May 16 and 17 should be days to remember!

**37** **Hilda Loveman Wilson**  
15 Lafayette Road  
Larchmont, NY 10538

With our 50th Reunion only a year away we have a message from our class president, **Irene Lacey Stahlin**: "Our 50th anniversary will take place in Barnard's 98th year and we have been around over half of her existence! That is certainly something worth celebrating so we hope you'll plan to join us there in May of 1987. We'll be filling you in with particulars. We never thought of Barnard as 'young' then, did we? May she ever remain so in her outlook."

Inspired by thoughts of the upcoming 50th, **Dixie Snedeker Kroeger** has finally made good on a resolution made 15 years ago to write the class editor and has brought us up to date on her very productive 49 years since graduation. I think she is proudest of being a great-grandmother twice, not to mention mother of four, grandmother of nine, and wife for 48 years last February. She strikes a chord, in me at least, when she says, "During the child-raising years I bowed to our culture and stayed home—and I did harbor resentment." But then Dixie went back to school, earned her MA in reading at Syracuse U, and for 13 years taught remedial reading at a nearby school. "I really loved it. Taught mostly one to one and that is the way to teach." As a certified brailist Dixie puts homework into braille for a local blind student—even her French lessons. And for 26 years she has headed the Service to Military Families for her local Red Cross Chapter. Recalling that she was a botany major, Dixie says she did put it to use, working for four years at the Boyce-Thompson Institute for Plant Research in Yonkers. And she remains an avid gardener. Dixie concludes, "I keep up with most of my old close Barnard friends and I do hope we can gather at our 50th." Hear, hear!

On a sadder note we heard from **Joan Geddes Ulanov**: "Our classmate **Harriet McClure Heald** died last Christmas after a long and difficult illness but also after experiencing the joy of seeing her great-grandchild! Her son, Anthony Heald, is now starring—to audiences' and critics' delighted acclaim—in the title role of *The Marriage of Figaro* on Broadway." I am sorry that I must report as well the death of **Georgine Hance Peisley** on Sept. 5, 1985.

An article in the Oct. 16, 1985 *LaVilla News* of Bentonville, AR brings news of artist and educator **Sandy Segard Rice** of Hot Springs Village, AR. Sandy exhibited 30 watercolor, acrylic and oil paintings at the DeSoto Club during November and December. The paper described Sandy as a "romantic colorist" and said, "It is her intent to give a poetic expression rather than a rendering or telling of a story." Sandy received her master's degree from Michigan State U where she was an assistant professor of art. Later she taught in the East Lansing schools and was named Michigan Art Teacher of the Year by the Michigan Art Education Association. The article states that Sandy's film, *Discovering Architecture*, is used for teaching in public schools and her articles are printed in national education publications.

**Shirley Adelson Siegel** is of counsel to Finley, Kumble, Wagner, Heine, Underberg, Manley & Casey, law firm at 425 Park Ave., NYC.

**Myra Serating Gaynor**, pianist, performs at retirement and nursing homes and the Dallas Library. She also works part time at the House of Books and swims regularly. Her daughter Joan is benefits officer at Colorado State U.

**Ethel La Pointe MacKnight** retired April of last year from the library of *The Daily Press* in Newport News, VA, but went back in the fall to do research for a centennial edition honoring the Newport News Shipbuilding and Drydock Co. She works in the literacy program for the non-English speaking and enjoys travel to such places as New Mexico, Boston, Montreal and Washington.

**38** **Adele Rosenbaum Currott**  
49 Berry Street  
Lynbrook, NY 11563

**Elspeth Davies Rostow** has been elected to the Board of Visitors and Governors of St. John's College, Annapolis, MD. Elspeth is former Dean of the Lyndon Baines Johnson School of Public Affairs at the University of Texas at Austin and is a professor of government there. She has taught at Cambridge, Georgetown and American Universities and at the Massachusetts Institute of Technology. She has served on numerous government commissions as well as on the Board of Trustees of Sarah Lawrence and Barnard, the Overseas Education Fund, and the College Board.

**Jean Libman Block** writes: "I moved recently from Articles Editor of *Good Housekeeping* Magazine to Contributing Editor. I write regularly for *Good House*, occasionally for other magazines. Active hobby: real estate development. Daughter Wellesley '66 living in London; son Columbia '68 in Philadelphia, two grandchildren."

Our star correspondent, **Marion Hellman Sandalls**, sends 1985 Sandalls Family Highlights: Jan/Feb: Husband Bill lectures a class on Portugal's history and culture for the New London Adult Education Program.

March: Bill and Marion take off again for Portugal via the Azores. Spend three weeks in Lisbon, Estoril, Cascais and Coimbra.

May/July: Daughter Helen becomes a JD (magna cum laude) at Arizona State University. She and Alec accompany John to Western Australia U where John is a visiting lecturer and consultant on environmental law.

October: Bill and Marion spend 3½ weeks in Europe visiting Normandy, Napoleon's birthplace in Ajaccio, Corsica, Garibaldi's retirement home and tomb at Caprera, Sardinia, and winding up in Tuscany. This trip was a lot of fun using local transport: buses, ferries and trains. Many details will be included in Bill's future lecture series.

Nov/Dec: Thanksgiving in Weston, Mass. with Bill, Jr. and family. All thriving. Christmas in Tempe, Arizona with Helen and Co., with a side trip to Los Angeles to see sister Doris.

Hats off to **Leonore Schanhous Krieger** for determinedly defying inclement weather reports and flying to Washington, DC for a day to lunch with **Kitty Smul Arnow** and browse through the National Gallery's Treasure Houses of Britain exhibit. Leonore managed to fit in two trips last summer: to Australia and to Israel, where she attended classes as well as field trips in archeology and ancient history.

**Helen Hirsch Acker** enjoyed a spring 1985 trip with her husband Howard to England, Scotland and Ireland.

Joining the ranks of the widely-traveled, **Vera Halper Schiller** and her husband Irv touched many bases in 1985: Mexico, Israel, Italy, Spoleto Festival in South Carolina, Philadelphia for the Chagall exhibit, to Irv's reunions at Boston Latin School and Harvard, to daughter Janet and her family in Irvington, New York, and to son and daughter-in-law at University of Georgia at Athens. Does this leave you breathless? More to follow in next issue.

**39** **Janice Hoerr White**  
664 Ridgewood Avenue  
Montclair, NJ 07043

In response to cards mailed in January, we have news. I purposely sent these inquiries to those of you who live pretty far west of this metropolitan area—and with malice aforethought. Summer is coming, and the urge to hit the road may then grab you as it does me every spring. Why not visit a friend and classmate en route?

In Tucson, AZ, **Dorothy Mountford Hartshorn** struck up a conversation with someone who turned out to be **Agusta Williams** from the class of '38, our

own *June Williams's* sister. "Eddie and I continue to have the best of both worlds," Dorothy writes, "summer on a lake in Michigan and lovely, sunny winter weather in Tucson."

From San Francisco, *Joan Raisbeck Tuteur* writes that she and her husband spend weekends at their cattle ranch in Napa, CA, and summers on their "tiny island in the St. Lawrence River off Gananoque, Ontario, near Kingston. Between us, we have seven grandchildren, ages ten to twenty-three, and active parents, eighty-seven to ninety-seven."

*Janet Younker Willen's* husband died last summer. Our tardy condolences, Janet. Joseph Willen was retired executive vice president of the Federation of Jewish Philanthropies.

*Marjorie Healy Taylor* celebrated a fifteenth wedding anniversary in Scotland last September. Marjorie's husband Mel is Curator Emeritus in the Bird Division of the Field Museum of Natural History and is still active in many projects there. In their combined families, they have nine grandchildren. In March, Marjorie and Mel had a rendezvous with Marjorie's sister-in-law, *Barbara Reade Healy*, in Martinique.

**40** *Phyllis Margulies Gilman*  
20 Arizona Avenue  
Rockville Centre, NY 11570

Our exuberant *Shirley Ellenbogen Rothkrug* reports from San Francisco that Reunion was Great. In addition to part-time sales promotion work, she is the Public Relations Vice President for San Francisco NOW. She gets exhilarated and rejuvenated at a weekly tap dance class and a theater appreciation class which includes play-reading and critiques. She would love visitors.

*E. Marie Boyle* wrote in October from Haverton,

PA that she had just returned from a trip to Vienna, Prague, East Germany and West Berlin. A thrilling trip, which had been planned to visit areas of music masters, including Bach. She heard several old organs played that are much the same as when Bach played them. She also saw and heard *Siegfried* in West Berlin's new opera house. Her comment: "People everywhere were friendly and wishing for peace." Now that she is back home, she is busy with her church, conservation organizations, retirement home and Townwatch.

Please send notes of cheer to *Gerry Sax Shaw*. Gerry has just come home from two hospitalizations; the first for the removal of a brain tumor, the second time for a blood clot on the brain. Her husband, Wally, was also hospitalized for surgery. Gerry's mobility will be restricted for a number of months. Her address is 42 East Mall Drive, Melville, NY 11747. As I said goodbye to her, she said, "I'll see everybody at our fiftieth."

Happy news from our class president *Caroline Duncombe Pelz*. Her son Sanford was married in December to Adele DiBiasi. Sanford is chairman of the science department and a physics teacher at the Browning School. Adele teaches French at the Elizabeth Irwin High School, both of which are in New York. Caroline's husband, Edward, has retired as director of personnel benefits for The New York Times. Caroline is still working as director of admissions at the Grace Church School in New York. Their daughter Patricia, a lawyer, is head of cataloguing at Fordham Law School. Pat got her real estate broker's license in 1985. She and her husband and family live near Caroline and Ed. Caroline's daughter Cami and her husband Peter live in Stony Brook, LI, where he is a professor of English and writing. Cami helps divorcing couples work out settlements without going to court. She was recently elected to the board of directors of the Divorce Mediation Council of NY.

I'm sure we can all take vicarious pride in Tracy Kidder, the son of *Reine Tracy Kidder*. Tracy won a Pulitzer Prize in 1982 for his book, *The Soul of a New Machine*. He is now on the best-seller list with *House*. Reine has retired from teaching English at Syosset High School. Her interests are cross-country skiing, sailing and gardening. The Kidders are about to add a room onto their house for Reine's husband, who is still practicing law. Reine wrote her master's thesis on "The Bible in Literature" and taught a course on that topic. It's one I would like to take.

My husband, Harry, and I just returned from a three week trip to California. Highlights of it were tramping through Muir Woods in the rain, a tour of Diablo Canyon Nuclear Power Plant, Carmel, Monterey, Big Sur, San Simeon, Santa Barbara, and visits with family and friends, particularly our son Larry who lives in Hollywood. In Los Angeles we had a chance to see the Getty Museum, and the Huntington Museum and Gardens in Pasadena. Theater, sailing, etc. Ours is a magnificent country!

We were sorry to hear of the death of *Frances A. Dinsmoor Sandstone* in July and *Audrey Blair MacKin* in October of 1985. Our sincere sympathy to their families.

Please send news.

**41** *Mary Graham Smith*  
Box 624  
Palm Coast, FL 32037-0624

Update on Reunion — In a few short weeks we meet again, to share, exchange, and enjoy news and views. President *Eleanor Johnson* (CONGRATULATIONS, Eleanor, on recent retirement from distinguished career with Chase Manhattan), Reunion Chairman *Jeanette Halstead Kellogg*, and Fund Chairman *Helen Williams Blackmon* have been meeting with classmates in the New York area to make this as great a Reunion as last. Be with us.

More good news about the career of *Dr. Jean Ackermann*, a prizewinning writer who has lived in Pacific Grove, CA since 1976: Jean has been appointed Playwright in Residence of The Western Stage of Hartnell College, a first for the playwright and for the company, which has expanded from summer to year round operation.

*June Wilson Bain* and husband Chet looked radiantly happy in photo sent to old Hewitt Hall friend (self), taken at marriage of son Jim to Anita Karkenny. Congratulations to *Doris Williams Critz* on her marriage to Herbert Warren Yankee on Nov. 29, 1985 in New London, New Hampshire, where the couple will reside at Crockett's Corner.

*Estelle Cross* and correspondent almost had a Florida meeting last spring but times did not mesh. Estelle continues to play with Boston Philharmonic.

At the Annual Meeting of the Barnard Board of Trustees in December, *Ethel Stone LeFrak* completed her term as a member of the Board. The following resolution was adopted: "that the Board of Trustees thanks Ethel Stone LeFrak for her dedicated service to Barnard College. Both as an alumna and as a Trustee, Ethel LeFrak has given generously of her time and energy in serving the College. Her efforts on behalf of the Spring Benefit have made this annual event a highlight of the College year, contributing significantly to Barnard's Scholarship Fund." Ethel, we are proud of you! Thank you.

*Babette Jacobson Sommer* has retired from her advertising career, most recently with J. Walter Thompson as a vice pres., research director. She hopes to audit some courses at Barnard "if (I) can make arrangements for parking (my) car." Good luck on all counts.

*Phyllis Carrie Zimmer* recently lost her mother, who died at the healthy age of ninety-five — she lived to see her great-grandchildren. This spring Phyllis visits England and Wales on a museum-sponsored and guided tour. Unfortunately, the tour coincides with Reunion. So sorry, Phyllis. We'll miss you.

*Regina Patterson Campbell* recently retired after 14 years as director of Brighton (NY) Memorial Library.

## In the News



**Dr. Jean L. Willis '40**, recently retired from the history department of Fairleigh Dickinson University, has been elected president of the Nutley, NJ branch of AAUW.

Dr. Willis's involvement in AAUW began while she was a doctoral student at Columbia in the 1950s. Since then she has participated in its Committee for International Fellowships and been the Fairleigh Dickinson representative to the New Jersey Division. Last fall she was appointed by AAUW's Educational Foundation to the Fellowships to American Women Awards Panel, which selects winners of major awards for graduate study. In 1981 she received an AAUW grant for her own research on Alice Paul, which led to a chapter on this "quintessential feminist" in the book *Feminist Theorists*.

An award-winning history major at Barnard, Dr. Willis "tried law school at Columbia briefly, but found I disliked it intensely." She spent the WWII years in corporate administration at a NYC bank and then returned to academe. "In truth," she told us, "I did not find myself until the last 25 years. I belonged in the classroom and if any

word describes my interests and my 'mind,' it is historian. Despite eye problems, I am continuing my research and writing on Alice Paul, lecturing to various groups and looking forward to a program in November which I have structured as president of the Bergen County Cultural and Heritage Commission. It will celebrate New Jersey's role in the framing and adoption of the U.S. Constitution."

Other community historical projects in which she has participated are the Bergen County American Revolution Bicentennial Map Committee, which she chaired, and the Bergen County Historical Society. She was also co-editor of *Rutherford: One Hundred Years at Work and Play, 1881-1981*. On the broader civic front, she has served on the Board of Big Brothers/Big Sisters, chaired the Rutherford Rent Board, and represented faculty on the Rutherford Town and Gown Society.

On the campus she provided leadership for a number of special programs, including a Women's Center Program on "Making a Change: Career Options," and a Bicentennial Program entitled "Community Conversations: The People of America." She was appointed chairman of the College of Arts and Sciences Research Committee of the Rutherford Campus in 1975, the year in which she achieved the rank of full professor.

Although Dr. Willis taught all aspects of American history, the undergraduate courses to which she draws particular attention are "American Social and Intellectual History" and, starting in 1977, "Women in American History and Politics from the Colonial Period to the Present."

In an article in her local newspaper, Dr. Willis was described as believing that history does not repeat itself. "This startled people," she notes, "but I believe each one of us is unique."

Deepest sympathy to two of our classmates: to **Betty Clifford Macomber** on the loss of husband William in December. To **Virginia Smith Hoag** and her sons George, Richard, and Jeffrey on the loss of husband and father George Jackson Hoag in November.

Your correspondent wishes to thank Eleanor Johnson for subbing for the February issue while MGS was abroad for extended time. Highlight of the trip was Experiment in International Living—Home Stay Program in India. We look forward to seeing you at Reunion and to keeping you informed of our classmates after that.

**42** **Marjory Rosser Phillips**  
39 Eggers Street  
East Brunswick, NJ 08816

Two more happy retirees heard from. **Margaret George Peacock** has taken extensive trips through Italy, New Zealand and Australia, with a cruise to the North Cape and short stops in Fiji and Tahiti. A trip to Alaska is planned for May. When not on the go abroad, Margaret is busy with church work as a member of the Session and is a season ticket holder for the symphony on Friday afternoons and the opera Thursday nights.

**Elizabeth Krane Covitt** recently retired from teaching high school math in West Hempstead, L.I. Not altogether retired from teaching, however, she is giving lessons in jewelry making, particularly enamelwork, a craft that has been her hobby for many years. Betty has one daughter, who is a systems analyst for NBC.

Last November **Helen Kandel Hyman** headed up a forum and panel discussion held in Newtown, CT on the subject of the sandwich generation, that is to say, the couple struggling to meet the needs of their children while trying to cope with the unexpected challenges of their aging parents. Besides co-authoring *You and Your Aging Parent*, now in its second revision since publication in 1976, Helen has written extensively on mental health and medical and family subjects, including radio scripts, documentaries, and pamphlets for CBS, NBC, and UNICEF.

The Torch of Conscience Award of the American Jewish Congress was recently presented to Bob and **Gerry Danzer Beer** of Dallas. Bob is a realtor who has been involved in a variety of educational and community relations agencies, while Gerry's energy has been channeled largely into community projects that help families, including The Family Place, Dallas's only shelter for battered women and children.

I always feel a little guilty about putting in personal items, as class correspondents should be read and not heard from, but I did have such a great trip in December to attend a family wedding in Durban. Having to rush back home for Christmas made it all too short, but I did manage three days at a game reserve where I discovered that the best animals to photograph are giraffes and warthogs. They're ugly but they stand still and face the camera.

**43** **Sophie Vrahnos Louros**  
11 Hillside Avenue  
Pelham, NY 10803

**44** **Martha Messler Zepp**  
114 Greenwood Drive  
Greenville, NC 27834

You probably rejoiced, as I did, to see in the Fall issue of the "Reporter" the report that the courtyard between Barnard Hall and the residence halls is once more an oasis to delight the eye as one enters from Broadway. Although we '44s see it only occasionally, it gladdens one's heart to know that one's memories still have some connection to reality!

**Ethel Weiss Brandwein** and her husband have let no grass grow under their feet since his retirement from the US Labor Department. "A new world has

opened," she wrote. They first tried out their new car in New England, visiting among others **Doris Bayer Coster '42**, now vice president of U of Hartford, and then spent a month in Europe in the Benelux (a term new to me) countries, Alsace, Switzerland, and northern Italy. In Holland they weekendened with **Tineke Van Walsam**, also '42. When back in Chevy Chase, MD, Ethel hosted **Shirley Sexauer Harrison**, **Mimi Gore Raff** and **Gloria Glaston Cole** at dinner. The final comment in her letter: "I think many of us are still feeling our way into this phase of our lives (i.e., retirement) and want to combine some continuing challenges with more travel and luxurious loafing."

**Judith Paige Quehl**, on the trail of out-of-print books for the '44 collection she is making, which will be turned over to the Barnard Library, sent on a letter from **Ursula Colbourne Brecknell**. Ursula has found her way over the years into work from which she will never retire—historical research on land, events, and architecture, and publication of the results. She lives in an area of rapid expansion in New Jersey, Montgomery Township, just north of Princeton, where tradition and innovation are battling for supremacy. When called upon for environmental impact statements, she is frequently asked by owners of historic sites to document their structures. In the offing is a book on Dutch architecture in central New Jersey.

Class treasurer **Dorothy Kattenhorn Eberhart** continues to work along with her husband in their Manhattan-based real estate business. She vows she is "slowing down" and unable to accomplish as much in a day's time as she once did, but one doubts the truth of this statement when listening to the active part she still plays in the lives of her four offspring. One daughter is a dancer (who lived four years in Argentina) and another is a marine scientist.

After **Virginia Meyer Cram** retired as a physical therapist a few years back, she declared she was "busier than ever." Since I reported this comment in the Spring column, I've discovered what keeps her occupied two hundred percent of the time. She and her husband, after building their own home in Montvale, NJ years ago, in the past year or so have set about remodeling it. At reunion time they were adding onto their vacation home and were planning to help her brother construct his home. Next in line for help was their daughter, who wanted a house addition and a solar collector. If you want to feel needed and useful, take a leaf out of Virginia's book!

**Mary Jane Rogers** retired several years back as editor of two weekly newspapers. If she has carried out her plans, she should have visited Ireland this year and be packing to move from Toms River, NJ to Seattle. Well, Midge, are you on schedule?

Retired after she had taught the blind for years in the New Ycrk area, **Virginia Benedict Katz** reports that she and her husband are living in Coral Springs, FL. Their two sons have enlivened their lives with two granddaughters and three grandsons.

**Betty Gormley Hubbell** came back to Columbia this year from her Washington, DC home to see a master's degree conferred upon daughter Ellen who completed the new nurse executive program. The steps of Low Library brought back memories, and the presence of something new, Barnard balloons, delighted her.

It is not our reunion year, '44s, but I look forward to visiting with as many as can be in New York in May.

**45** **Daisy Fornacca Kouzel**  
54 Cayuga Avenue  
Atlantic Beach, NY 11509

As I was about to start this column I received the news that my father had passed away, five months shy of his 90th birthday. Fortunately I had visited him recently in the beautiful nursing home on Lake Maggiore near Milan, where he had spent the last few weeks preceding his death. To cheer myself up I will quote almost in toto a very amusing letter from **Ruth Bischoff Hucklebridge**, who, after expressing regrets at missing Reunion, writes: "We've hung up our

traveling shoes—our recent misadventures in South America cured us of wanderlust. We went to Lima, Peru planning to visit Ica, Pucallpa, Cuzco and Machu Picchu, and then on to Brazil. We traveled with Unique Adventures, and it was unique all right! Ted and I were the tour. Our guides spoke only Spanish and Quechua (an Indian dialect, and of course we are both fluent in Quechua, ha!). We got stuck in the reeds on a tributary of the Amazon, and when the boatman got out to cut the reeds he was covered with leeches (shades of *The African Queen!*). At Cuzco we thought if one cup of coca tea helps altitude sickness, four cups would surely cure it. Instead, we experienced our first high! Speaking of high, the train after ours on the Machu Picchu line derailed because the engineer was drunk. When we got to Lima for the flight to Brazil we found that our visas were invalid and it took three days to get new ones. In Lima we were cooped up in a hotel watching demonstrators demanding higher wages being dispersed by firehoses. . . Ah, but Peru and the ancient mysteries of the Incas were marvelous. At Cuzco we delivered a Braille watch to a blind 90-year-old musician (the great-uncle of Alan Garcia, Peru's new President) and he showed his gratitude by playing his harp for us alone. At Machu Picchu we were stunned by the ruins of the Lost City. For the Inti Raymi Festival (a celebration of the sun featuring processions, songs, dances, and fake animal sacrifices), we joined thousands of Indians who had come from many miles away. Finally in Rio the sight of the Iguassu Falls fulfilled a lifelong dream, and best of all we took lots of sound motion pictures of everything in sight."

Well! Ruth's reportage fills me with desire to see those places, and incidentally I don't believe she's lost her wanderlust, for which there is no known cure.

**Dare Reid Turenne** was prevented from attending Reunion by the earthquake which rocked Chile last March. She had to oversee the repairs and sale of the house and move into an apartment overlooking the Pacific (the first time they have such a view in 32 years). Then daughter Sandra got married—another busy spell. Dare and Rodolfo are delighted with their toddler granddaughter Lucia, the child of Dare, a physician. I am very grateful to Dare for writing me news on a regular basis, and wish other classmates would follow her example! As I told you many a time, the excuse that you have nothing interesting to write about just doesn't hold water!

I thank **Jacqueline Baumann Wolgel** for her news update: her husband Milton retired after 40 years as a physician, Jacqueline having worked with him for the past seven. Their daughter is in the Video Dept. at CBS, and their son is a urologist. The Wolgels now travel extensively.

**Elaine Engelson Schlanger** and husband Robert are moving from Great Neck (L.I.) to Longboat Key, FL, where they are building a house.

Next time I will report on the multifarious activities of **Hilma Ollila Carter**, who as you know is the wife of the famous jazz musician Benny Carter.

In the meantime, I would like to drum up some support for Professor Amelia de del Rio's Museo de Reproducciones Artisticas in Puerto Rico, to which she has been devoting her retirement (?) years. If some of you who were her students want to make a contribution, please let me know and I will supply details.

**46** **Charlotte Byer Winkler**  
17 North Pasture  
Westport, CT 06880

On May 16 and May 17 our class will have our 40th Reunion. It is not too late to join us; please call **Lorna Pitz Bunte**, (201) 464-0412.

From Clarendon Hills, IL **Dr. Patricia McClement Failla** writes that she retired in January from Argonne National Laboratory after 25 years. She has built a house on Seabrook Island, about 20 miles south of Charleston, SC. Pat plans to play golf and be outdoors all year 'round.



Nancy Cahen presented a paper, *Don Quijote*, at the symposium "A Celebration of Cervantes" which was held at the Library of Congress this past October. The event was co-sponsored by the Hispanic Division of the Library of Congress and the Cervantes Society of America. Nancy used musical illustrations in her presentation. She is an assistant professor of Spanish at Stern College of Yeshiva University. Nancy wrote that she has "maintained close contact with the bassoon" since high school days, playing with various orchestras, ballet and opera companies, and chamber ensembles. She is currently bursting with pride; her niece *Judith Sokolow '73* was responsible for the camera work and editing of a recent awards-winning documentary "Whispering Hope: Unmasking the Mystery of Alzheimer's." Judy is a founding member of Medvideo, Ltd., which produced the film.

Hazel Jane Davis Heaton's husband Bud retired February 1. They celebrated with a lengthy vacation on St. Bart's. Last spring Hazel Jane spent six weeks in Paris as well.

Speaking of travels, *Jackie Branaman Bogart* and *Betty Ann Wallace Gordon* spent three weeks in China last summer. Jackie reminded me that Betty Ann grew up in China.

Helen De Vries Edersheim attended the 40th reunion of the Dutch Air Force at Utrecht, the Netherlands with her husband Hans last summer. These Dutch airmen served under Gen. MacArthur in a special unit during WWII. Over 400 people attended from all over the world.

Hearing about such exotic places makes my own trip seem quite mundane in comparison. It was still quite an adventure for us. We took our sailboat up to the 1000 Islands for the summer via the inland circle route which utilizes the NY State canal system, Lake Ontario, the St. Lawrence Seaway and Lake Champlain. Fortunately we were behind schedule returning to L.I. so Hurricane Gloria caught us way up the Hudson River instead of in L.I. Sound as the family feared.

I had hoped to pick up some news at the winter cocktail party for the '40s classes at the Barnard Club of NY. However, it was cancelled. Helen Edersheim has passed along the tidbits she gleaned while making the cancellation calls to our classmates. *Marion Gluck Rothman* has recently become a grandmother twice. *Mary Lou Hannigan* is taking early retirement from Union Carbide in Connecticut and plans to move south.

You can tell that your class officers have been in touch. Without their contributions this column would be rather lean this time. Are you remembering to think Reunion '87? We are.

Apologies from your correspondent for missing the last two columns. I was out of the country for two months from late September until mid-November 1985, and what with making preparations for the trip and then settling in on our return, I seem to have missed my deadlines. My husband and I visited Denmark, England, China, and Japan. We spent several days in Denmark, mostly visiting old friends from our long-ago sabbatical year; then a week in England with a few trips to some stately homes in anticipation of the "Treasure Houses of Britain" exhibition at the National Gallery of Art. In China we spent a week in Beijing where my husband gave lectures at Peking University and Beijing Normal University. Then on to Shanghai for two weeks and a series of seminars at the Shanghai Jiao Tong University. We were very impressed by the enormous changes in China since our first visit in November 1979. Our trip ended in Japan, where our older son,

Joshua (now a technical writer for Sperry Corporation in Reston, VA), joined us for a wonderful week in Kyoto and Tokyo. On the way back to the USA we stopped in Los Angeles for a few days to see our younger son, David, who is working there as a film animator and free-lance cartoonist.

We are not the only ones who have been traveling, as I learned from a letter from *Doris Jacoby*, sent from her home in Frankfurt-am-Main. She is still working part-time for Diesterweg on German and English textbooks, and continuing her Japanese studies at Johann Wolfgang Goethe Universitat. She also is on the board of the Deutsche Japanische Gesellschaft and arranged a Japan Book Week with the Japanese Consulate General during Japan Week in Frankfurt. During the snow-free months of the year she spends time at her chalet in the Tyrol. Last February she spent a week in southern Spain enjoying the Spanish-Moorish cities of Granada, Jaen, Cordoba, and Sevilla—but not the Costa del Sol with its concrete hotel facades. In June she visited the lovely chateau country of the Loire valley in France, except that the weather was too bad to enjoy the scenery. In September 1985, Doris says, she made her wish come true to visit her adopted country and old friends in the United States. First stop, New York—where in Manhattan she was robbed of all valuables including her passport! The rest of the trip, however, was enjoyable—the New England autumn in Massachusetts, Virginia on the outskirts of Washington, DC, and then out to Seattle and the Pacific Northwest. And visits with good friends everywhere. Many thanks, Doris, for your interesting and news-filled letter.

*Ruth Trencher Rosenbaum* writes: "Still teaching—enjoying it. Both daughters are married and live near us here in Virginia. We are blessed with four grand-(very grand!) babes. Best wishes to all my classmates."

Two of our 1948 alumnae are professors at Barnard. *Joan Lyttle Birman*, Professor of Mathematics, visited universities in China and South Korea during August 1985. She gave colloquia at Fudar University, Shanghai, on August 12 and at Peking University, Beijing, on August 19 on "The Jones polynomial."

*Ruth Montgomery Kivette*, Professor of English, received her JD in May 1985 from Fordham University Law School. Ruth also has her BD (1954) from Union Theological Seminary. Last autumn she addressed the Barnard College Club of New York on "The Book of Job."

In closing, I regret that we must once again note the passing of one of our classmates. *Barbara Burtner-Elfreth* died on June 13, 1984. Our deepest sympathies to her daughter, Barbara E. Chase of Caspar, Wyoming.

I wish you all a warm and happy springtime, and hope to be hearing from you.

A smattering of news from *Ruth Dossick Miller*, who writes that she continues to work as curriculum supervisor for foreign languages in the Teaneck, NJ schools. Her present language project is studying Hebrew. Son Philip attends Columbia College and is due to graduate this spring.

Alumnae Council, held November 1 and 2, 1985, brought some of us together. *Jane Ritchie Rice*, *Rosary Scacciaferro Gilheany*, *Ruth Musicant Feder* and *Marian Gutekunst Boucher* attended what was an outstanding Council—bringing us up to the minute on campus life at Barnard and how Barnard is leading the way for women's colleges in America. Over luncheon, changes in lifestyles were voiced by Jane, who has gone into the business of real estate; by Rosary, who spoke of a vastly different approach to her job as head librarian brought about by the new

## Barnard Bartending Agency

# A Shot of Class

Bartenders and Party Help  
Available  
for all your party needs

For information call:  
280-4650

Managers: Rebecca Cohen  
Vivian Ladd

"electronics"; and by Marian, who has entered the field of free-lance writing.

We express our heartfelt sympathy to the family of *Julia Martin Embree* who died in December 1985.

The winter solstice has passed the midway point and with spring in the offing, thoughts turn to Reunion. For our class, 1986 marks our 37th anniversary—and as always, Reunion is a wonderful time to recapture memories, renew friendships and rekindle our school spirit. Looking forward to seeing you there.

*Barbara Dawson Briller* writes from Pennsylvania of her 90-year-old father: "His main problem is macular degeneration of the retina, which destroys the central vision needed for reading and recognizing faces. Peripheral vision remains, making it possible to see forms, trees, stop signs, etc. Daddy can still take his twice-daily walks alone. His peripheral vision is fading, but he still reads the *Wall St. Journal* with the aid of a closed circuit TV which magnifies print 40 times. I would like to hear from classmates whose parents also have macular degeneration. How are they coping? Did their ophthalmologists tell them about the visual aids available? Have they formed a support group? Did the various associations for the blind help them?"

Barbara does publicity for Sewickley's non-profit nursing home. While visiting her father in Sun City, she got an idea for publicity in the Pittsburgh area. "Did you know that people who can't read for any reason—vision, stroke, unable to hold a book—can get, free, a special radio receiver which picks up an FM station which reads the daily newspapers and magazines?" Barbara can be reached at 524 East Dr., Sewickley, PA 15143.

Barbara's close neighbor is *Jean Scheller Cain*. Jean and Barbara attended our Reunion together last May, after which the Cains left for a trip to the USSR, flying from Moscow to Kiev, where they boarded a cruise ship for a trip down the Dnieper. "We stopped almost every day for 10 days, visiting the Ukrainian towns along the way, until we arrived in Odessa. From there we entered the Black Sea and then one of the many mouths of the Danube, with Bulgaria on one bank and Rumania on the other. We

...left the ship in Rumania, spending three days in Bucharest, a depressing but essentially lovely city."

Congratulations to **Helen Rippier Wheeler**, whose course proposal, "Japan-America Connections: Knowing About Japanese Women," received First Place Award in the Women's Inst. for Freedom of the Press 1985 competition. Helen was visiting scholar and guest lecturer in women's studies at Toyo Univ. in Tokyo during spring and summer '84. She also lectured at the National Univ. of Library and Information Science in Tskuba City, and to the alumni group of Keio Univ. Library School, and was entertained by **Yumi Shitoto Sugimoto '74**, in her suburban Tokyo home. Helen teaches at UC-Berkeley, and is sole proprietor of Womanhood Media, a consulting service focusing on gender equity.

**Beverly Beck Fuchs** is Director of Group Services at the Senior Center of Palo Alto, CA. Two of her four children (all graduates of Wesleyan Univ.) are married, and she has 3 granddaughters. In March, Beverly and her husband Vic, professor of economics at Stanford, were speakers at "Stanford Focus on Professional Women" Day. Their subject: "Having it All?" Their answer: "You can't."

Continuing travels of **Muriel Kilpatrick Safford**: The Saffords returned from China and Tibet "to spend Christmas with our family. . . What we didn't bargain for is -12° temperatures! We live in our former country house when we are home. It is about 150 years old, a farm house which is uninsulated except for the kitchen. . . Come February we'll head back to Europe and in March go to Egypt with old friends on an Alumni Flights Abroad tour (conducted by an Egyptologist—so we'll have to do some homework beforehand)."

**51** **G. Brooks Lushington**  
#125, 1465 East Putnam Ave.  
Old Greenwich, CT 06870

**Alice Kogan Chandler**, President of SUNY-New Paltz, has been appointed to the Commission on the Future of State Colleges and Universities, of which former Secretary of Education Terrel Bell is chairman.

**Gertrude Schmitz Frey** has taught at Nutley (NJ) High School for 14 years and is still enthusiastic about it. A member of the committee to improve writing skills of pupils at all levels, she also works with the school's Human Relations Club. (This information was supplied by her husband, who is very proud of her work.)

**Elna Loscher Okin** works at AT&T Technologies on a new process for managing manufacturing and marketing throughout the company. She reports her life is hectic, but interesting. She has a daughter in law school, about to graduate, and another daughter heading in that direction. She also has "a geophysicist and one teenage boy, interested in driving and girls (or girls and driving)."

**Muriel Turtz Small's** daughter-in-law, **Martha Yepes Small '77**, had her first son, Alexander Charles, on November 22, 1985.

We are sad to have learned of the death of **Nancy Van Arsdel Campbell** on January 4, 1986. The Class extends its sympathy to her mother, Mrs. F.K. Van Arsdel, and her sons, Thomas and Steven Campbell.

Classmates— are you aware that this May will be the occasion of our 35th Reunion? Whether this is appealing or appalling, there's a lot to be said for survival, for friends, for Barnard memories. Yes, you have a Reunion committee; yes, there is a remarkable similarity of this committee to the one that planned that notable 30th Reunion. Yes, WE NEED YOU! We need ideas, input, helping hands, imagination and more of you out there to help, even if May 16th and 17th are just around the corner. Please write, call, send courier pigeons or whatever to me, to **Naomi Loeb Lipman** or **Marisa Macina Hagan**.

My daughter Nancy and her friend, Richard Barber, run "Paradise" at 444 West 43rd Street. Stop in, have some of the best homemade soup, scones, coffee, tea and of course, ice cream you've ever had!

Nancy is still dancing, too, and recently filmed an ad for TV.

**52** **Carol Connors Krikun**  
345 12th Street  
Cresskill, NJ 07626

**Edith Richmond Schwartz**, professor of orthopedic surgery and physiology at Tufts Medical School, was honored with a Kappa Delta Award at the annual meeting of the American Academy of Orthopedic Surgeons in February. "Interestingly," wrote Edith, "the only other woman to receive such an award was **Adele Ludin Boskey '64**."

From Chevy Chase, MD, **Joan Oppenheimer Weiss** writes: "After directing a national symposium for genetics support groups in the country, I helped form an 'Alliance of Genetics Support Groups' which will be the combined health care consumer voice for such concerns as the controversial gene therapy. I continue to team-teach a course at Georgetown U Hospital, 'Incorporation of Genetics into the Clinical Practice of Nurses and Social Workers.' In addition, I continue my part-time job at Johns Hopkins as social worker in the genetics clinic."

**53** **Stephanie Lam Basch**  
122 Mulberry Road  
Deerfield, IL 60015

We were saddened to learn of the death of **Lois Wersba Roth** on January 13. She had been a Foreign Service officer with the US Information Agency since 1967, most recently serving as director of its visual and performing arts program. Her overseas posts included Paris, Rome and Tehran. In 1981, the Fletcher School of Law and Diplomacy published her history of the USIA, *Public Diplomacy and the Past: The Search for an American Style of Propaganda*, which received the USIA's Superior Honor Award. We extend sincere sympathy to her relatives and friends.

**Pat Leland Rudoff** and her husband Paul and daughter Deborah are all involved in the South Shore Symphony on Long Island. Paul is music director; Pat, who studied at the Mannes School of Music, plays the violin, and Deborah is a violist. Pat also teaches at Nassau Community College and Queens College.

**Carol Wolfe Galligan's** son Zach, a senior at Columbia College, has already made a big name for himself. He has starred in several recent movies, including *Gremlins*, and was seen in the TV drama, "Prisoner Without a Name, Cell Without a Number." *People* magazine put him on its cover for his lead role in "Surviving," a TV drama about teenage suicide.

**Barbara Lewittes Meister**, a resident of New York City, writes that she is married to Victor Trasoff, Art Director of Wm Douglas MacAdams Advertising. Her fourth book, *Yes, We Sang!*, was recently published by Harper & Row, and deals with songs important to those in ghettos and concentration camps in WW II. She is still involved with her concert career, often with son Matthew, a cellist. In addition, she will soon have her 4th grandchild. The other three range in age from 1 to 6.

**Rochelle Reibman Hirschhorn, MD** writes that both daughters, Melanie and Lisa, were engaged last fall and will be married this year.

We're allotted a good deal more space than this—if you drop me a note filling me in on any pertinent information you'd like to see in this column, I'll be happy to include it in future issues.

**54** **Louise Spitz Lehman**  
62 Undercliff Terrace So.  
West Orange, NJ 07052

Only one item of news this time—**Doris Barker Shiller** has been named a principal in Berkowitz, Balbirer, Weisman & Lubell, PC in Westport, CT.

**55** **Patricia Dykema Geisler**  
526 West 111th Street, Apt. 2B  
New York, NY 10025

**56** **Janet Bersin Finke**  
518 Highland Avenue  
Ridgewood, NJ 07450

It's not too late—you can still make arrangements to come to Reunion on May 16th and 17th. Don't let the chance slip by.

**Sarah D. Gray** was in China last spring with a People-to-People delegation which presented a series of epidemiology lectures in several cities. By chance, the roommate assigned to her was **Eleanor Kapp Darby '25**, a retired grants administrator from the National Institutes of Health. Dr. Darby had just attended her 60th Reunion at Barnard.

**Marcella Ottolenghi Buxbaum** continues as chairman of the Department of Foreign Languages at the Hewitt School in Manhattan. Her son Victor is in San Francisco, studying at the Iyengar Yoga Institute and working. Her second son Laurence is in his third year at MIT.

**Sifrah Sammel Hollander** is coordinating the internship program for seniors at the Law and Humanities Institute of Forest Hills High School in New York. She places students in law offices, Legal Aid, with judges, politicians and museums. Sifrah, who finds teaching exhausting but rewarding, is frequently asked to write letters of recommendation to colleges, including Barnard. She also works with foreign students from over twenty countries. Her sons are in 7th and 10th grades.

**Imelda Llorens Gallagher**, chairman of the Sewanhaka High School Science Dept. and Coordinator of the Talented and Gifted Program of the Sewanhaka Central HS District, has been elected president of the Nassau County Science Supervisors Assn.

**Sally Brinsmade Litchfield** is teaching acting classes for elementary school-age children after school in Larchmont and Saturdays at the Emelin Theatre in Mamaroneck.

**Michaela McLane McCausland** and William Waddington were married on February 22 in Bernardsville, NJ.

After 30 years in scientific research, **Liane Reif-Lehrer** has made a major career change. In addition to now working primarily as a free-lance writing consultant, she is also doing some product development. As President of Tech-Write Consultants in Belmont, MA, Liane runs workshops on improving business writing skills, works with individuals, and restructures business, scientific and technical documents. Her clientele is almost exclusively the business community "because usually academics can't afford to pay for consultants." Occasionally a physician who is short on time uses her services, thus renewing her tie with science. Good luck, Liane!

**Mina Schenk Hechtman** sends good news and not-so-good news: son Daniel will be receiving his MD with honors from Washington U, but that happy event coincides with Reunion, so she can't attend. We'll miss you, Mina. The other Hechtman children have returned to the Boston area: Julie is a marketing manager at Lotus in Cambridge, and Abby is at Boston College Law School.

**Carol Richardson Holt** writes: "Since July, I have been Director of Child and Adolescent Services at the Guidance Center in New Rochelle and am in private practice as well. I am *really* happy to be back in my native state of NY.

"My daughter Liz is a senior at Barnard, majoring in biology. She was on the Dean's List last year. She loves Barnard as much as I did. My son Stephen graduated from Taft in May and is a freshman at Georgetown School of Languages and Linguistics, majoring in Chinese. He spent nine weeks in Beijing during the summer of 1984 studying the language, having begun it the summer before at the Yale Summer Language Institute.

"I still remember our twenty-fifth reunion with great pleasure and regret that I will not be able to join

you for our thirtieth."

Here are some more names of members of the class who have dropped out of sight. Please let us know if you have any news of them. *Betty Hellman, Judy Frank Jablow, Roberta Berkowitz Jacobson, Lyana Feldman Kahn, Carol Sand Kaplan, Marina Moskow Kaufman, RONALDA WHITMAN KEITH, Nellie Commager Lasch, Roberta Isaacs Mathews, Joan Mayer, Marilyn Mass Milligan, Anne Muller-Thyme, Catherine Peskedji, and Judith Rigg.*

I'll be reporting to you about Reunion, but that will be my last stint as Class Correspondent. I'm happy to tell you that someone else has already agreed to take the job, and hopes to hear from you. From now on, please write to *Peggy Gilcher Siegmund*, 616 Uluhala Street, Kailua, Hawaii 96734. Regular first-class postage is all that's needed to get there.

57

*Judith Jaffe Baum*  
150 West 96th Street  
New York, NY 10025

*Rayna Schwartz Zeidenberg*  
65 Tillinghast Place  
Buffalo, NY 14216

If the quantity of news that classmates seem eager to share is any indication, it would seem that our class is revving up for #30.

*Sidra Levi Winkelman* writes from Sherman Oaks, California that her daughter Claudia will be graduated from Barnard in May. Claudia loves Barnard, and Sidra enjoys comparing the College as she knew it with the way it is today. Her older daughter is at Columbia Law School, and her younger daughter will be graduating from junior high school. Sidra (who has a PhD) and her husband are psychotherapists and recently collaborated on a book, *Embracing Our Selves*, in which they explore a new way of looking at ourselves called Voice Dialogue.

From Phoenix, Arizona comes a Prudential-Bache Securities announcement that *Marilyn Melton Brooks* has been appointed Associate Vice President-Investments. Marilyn has two sons: Zach, a computer consultant and himself the father of twin sons, and Neal, the owner of a plant-growing business and newly married. Marilyn's husband Norton has retired from employment with the City of Phoenix to join Neal in business.

*Renee Feuerman Waltzman* is practicing law in Brooklyn—full time, now that her children are on their own. Her daughter Elise is a Brown graduate and hoping to become a film writer, and her son Roger is a sophomore at Brown. Renee's husband Allan is an associate professor of child psychiatry at Downstate Medical School as well as a psychoanalyst in private practice.

On April 10, *Linda Schott Weiss* was honored as the Volunteer of the Year by the New Jersey chapters of the National Foundation for Ileitis and Colitis. She has been very active in their work of raising funds for research, providing educational brochures, and sponsoring support groups and medical seminars. Linda's husband Larry is a judge in Union County, her daughter Judy is a pediatric nurse at Mt. Sinai Hospital and a graduate of Columbia School of Nursing, and her son Michael is a senior at Syracuse.

*Irene Newman Mendelson* runs a consulting firm (BEMW, Inc.) in suburban Washington, DC which serves individuals, government and industry in the areas of career management and human resource development. Her oldest son is a Wesleyan graduate, her middle son will graduate from Oberlin in June and her youngest son is still in high school. Irene's husband is a cardiologist.

From Lancaster PA comes word that *Therann Gamba Ferrier* is coordinator of off-campus study, foreign student advisor and lecturer in German at Franklin and Marshall College. She received an MA from Middlebury College in 1960.

*Rochelle Siegman Strauss*, who lives in Belle Terre on Long Island, reports that her son Michael is

practicing law with his father's firm and that her daughter *Jackie*, Barnard '84, is with Merrill, Lynch et al in NYC.

Finally, a roundabout bit of news: *Phyllis Shapiro Worby* sent us part of a newsletter from a Long Island poetry group to which she belongs. Phyllis highlighted that *Emilie Bix Buchwald* and Ruth Rosten, the Minneapolis editors of a publication called *The Sporting Life*, are looking for poems and essays for an anthology on sports and games to be published in October 1986.

58

*Elaine Postelneck Yamin*  
775 Long Hill Road  
Gillette, NJ 07933

*Barbara Barre Weintraub* writes that now, at the midpoint between Reunions, she is looking forward to our next one and wants to bring us up-to-date on family affairs. "*Bev* (Barnard '82) and husband Howard (Columbia '80) live in Manhattan. Howard practices law by day while she works the strange hours of an editor on a daily paper in NJ by night. Sharon (NYU '85) is holding down two jobs—one at the NYU Choral Arts Society and one at the Technical Department of the Metropolitan Opera. I must have her schedule posted to keep track of her. I am still technical editor at a large electronics firm on Long Island. Gerry and I shared the unique experience this past year of singing with the Long Island Philharmonic Chorus under the direction of Christopher Keene. I still feel a sense of wonder at being part of a concert and watching the conductor from that angle. Looking forward to seeing you at our next reunion!"

*Karen Gumprecht Komar* writes: "I have never written to the *Barnard Alumnae Magazine* before, but my experience this summer triggered a desire to share with my classmates a rather curious situation. Most of us have probably seen the popular film 'Back to the Future,' in which a 1985 teenager is accidentally sent via time-travel to the year 1955. There he meets his parents as teenagers and interacts with them as though they were his peers. I happened to see that film this past August during the very week I was performing the leading soprano role in Gilbert and Sullivan's *Gondoliers* with a new summer stock company in residence at Boston College. Most everyone in that show was in my children's generation.

"I had first performed in the *Gondoliers* at Barnard in 1955 (it could have been the fall of '54). My performance this summer with a very young cast gave me the feeling of being back in 1955, yet viewing the scene from the perspective of 1985. Time seemed to have stopped, and I seemed not to have aged. Michael Fox's experience in 'Back to the Future' was thus not entirely unique.

"But enough of that. I left Barnard singing, and I'm still singing. I received a master's in voice from the New England Conservatory in 1971, went to Tanglewood on a voice fellowship in 1972, and have taught at the New England Conservatory in the Extension Division Voice Department for the past 13 years.

"I have three sons, including a pair of 20-year-old identical twins who became celebrities of sorts when they were chosen as Quiz Kids for a Columbia Pictures television production in 1980. They earned their seats on that show primarily for their highly specialized knowledge of birds. At present, Oliver, one of the twins, is marketing a strategy game called *Rupicola* that he and a partner designed. All three of my sons and I were editors of and contributors to *Newsweek's* 'Ultimate Trivia Game.'

"The trivia game was truly a family venture, as it was my nephew who conceived the idea of the game and, with two partners, persuaded *Newsweek* to distribute it as a subscription premium. Our work was ultimately seen by all of *Newsweek's* new subscribers. Our aim was to outdo Trivial Pursuit in entertainment value and accuracy, and thus establish ourselves in the trivia market. We may have succeeded in our first goal, but failed in our second. Our



## PLANNING TO BE IN NEW YORK THIS SUMMER?

Are you wondering where to find a place to live? We have the answer for you—conveniently located and reasonably priced—the Barnard dorms.

Dormitory facilities will be available from the end of May through the middle of August and may be rented for the entire time or for as short a period as one week. Options include single and double rooms, air-conditioned or not. Regular dormitory services will be provided, including round-the-clock coverage of reception desks and access to on-site laundry facilities.

For additional information and room reservation forms, call Jean McCurry, Director of Summer Programs, 280-8021, or write to the Summer Programs Office, 3009 Broadway, NY, NY 10027-6598.

## LOOKING FOR SPACE FOR A SUMMER CONFERENCE IN NEW YORK?

The Barnard campus can provide an ideal setting for meetings of your organization. Dormitory facilities and meeting rooms of several types are available at reasonable rates.

For further information, call or write Jean McCurry, Director of Summer Programs, 280-8021.



retail version hit the market too late. The trivia boom had gone bust. F.A.O. Schwartz was the only store in NY that carried the game."

**59** **Regina Jerome Einstein**  
630 King Street  
Chappaqua, NY 10514

**Judy Weber Taylor**  
90 Virginia Avenue  
Plainview, NY 11803

As many of you have expressed an interest in a mini-reunion, plans are being made. We expect to have a Saturday or Sunday brunch at Barnard in October or November 1986. This is expected to be a warm and informal social get-together with lots of time for the exchange of ideas and personal news.

**Daphne Abeel** is an editor at G.K. Hall Publishing Co. in Boston. E.P. Dutton has published a new novel by **Firth Haring Fabend** entitled *Greek Revival*.

**Judith Basch Shapiro** writes that she has enjoyed meeting with classmates since moving to Newton, MA in '83. She frequently sees **Paula Schreiber Kaplan**, **Jane Beardsley Lemeland** and **Barta Droste Nevel**. Judith writes, "I am playing with the Handel and Haydn Society and the Tamarack Trio and am teaching at the New England Conservatory and at Tufts University."

**Nancy Farriss's** book, *Maya Society Under Colonial Rule: The Collective Enterprise of Survival* (Princeton U Press, 1984), was honored at the Annual Meeting of the American Historical Association as the "best book in English on the history of the US, Latin America or Canada from 1492 to the present."

Thanks to all of you who have supplied Judy and me with information about your activities. If you haven't written or called, please take just a few minutes to jot down a few lines about yourself.

—Gina

**60** **Dr. Muriel Lederman Storrie**  
501 Cranwell Circle  
Blacksburg, VA 24060

Our class co-fund chair **Mary Gallagher** has moved to New York from San Diego. She can be reached through her office, Dean Witter Reynolds, at 40 West 57th Street.

As I was glancing through *ASM News* (that's the American Society of Microbiology), I noticed that **Judy Zuckerman Medoff** was an "alternate" in one of the sections. It wasn't clear which office she was an alternate to, so I called her to find out. She's not sure either but I found out that she has been promoted to full professor of biology at St. Louis University and is president-elect of Sigma Xi, the honorary research society. She plans to be on working sabbatical next year, devoting full time to research on fungal differentiation. Her two sons (one a high school senior, the other a junior) play football on the same team, which won the state championship. Judy's eldest was chosen all-league, all-district best guard.

From **Norma Klein** comes this message: "I'm still publishing novels for adults and teenagers. The most recent were *Lovers* (Viking) and *The Cheerleader* (Knopf). My husband, Erwin Fleissner, is still a molecular biologist at Sloan Kettering. Our daughter Jen started Yale this fall. Our younger daughter, Katie, is in 10th grade at LaGuardia HS (formerly Music and Art) in NY. My brother got married for the first time last year and now has a baby daughter, and my mother graduated from college at the age of 77!"

**Dr. Barbara Zeitlin Burton** was one of the panelists at a seminar last fall in New London, CT on the problems of being a parent in the '80s. She is a pediatrician in Waterford and a member of the child protection team at a New London hospital. She is also director of the Southeastern Regional Health Services to Handicapped Children's Clinic and Child Development Clinic.

**61** **Hinda Rotenberg Miller**  
114 Oakdale Drive  
Rochester, NY 14618

**Nancy Kipnis Miller**, professor of Women's Studies and Chair of the Women's Studies Program at Barnard, continues to "keep her hand in" French, the area of scholarship where she began her academic career. In November she was one of the moderators of the Ninth International Colloquium on Poetics held at Maison Francaise and attended by scholars from the United States and France.

Some success in response to my request for current addresses of classmates—at least one "missing person" reported in: **Margo Newcomer Madden** writes that she can be found, "fat and sassy, in York, PA, with husband John Madden and William 11 and Elizabeth 8, both truly adorable." She is a copy editor at the local paper, a job she's held for about five years since moving from Queens. If she attends Reunion, she claims it will be the first time she'll have set foot on campus since graduation!

Speaking of Reunion, remember the dates: Friday and Saturday, May 16-17. You should have received a brochure with reservation form attached. If you didn't get it, or mislaid it, it's not too late to sign up. Call the Alumnae Office for details—280-2005.

**62** **Barbara Lovenheim**  
315 East 65th Street, #5J  
New York, NY 10021

On Sunday, April 6th, classmates met for an afternoon party at **Shari Gruhn Lewis's** home in Manhattan. Our 25th Reunion is now in the works—those wishing to help should contact Shari (120 E. 95th Street, NY, NY 10028).

Congratulations to **Karen Kissin** who was married this fall to her companion of the past several years. Karen is still working as an art consultant and curator in Ottawa, Canada.

**Libby Guth Fishman**, a general counsel and secretary of the Mellon Bank, was named Women In Business Advocate of the Year by the Philadelphia district of the Small Business Administration.

**Carolyn Brown Disco** is completing her fourth year as a communications manager for a public utility holding company. Husband Nelson works in ocean engineering for a large electronics company. Daughters Michele and Marilyn are students at Smith—Michele, a dean's list scholar, is spending her junior year in London. Son Will, a sophomore in high school, is in the marching band and on the ski team. Good luck, Carolyn!

**Renee Brosell Garrellick** has been recording history in Concord, Mass. A staff writer on the local newspaper, *The Concord Journal*, she has just completed coordinating Concord's oral history program, which was published as a book last fall in time for the town's 350th birthday. She is also working on a research project about the 19th century diaries and letters of a prominent local resident. And just to make sure she's never bored, she is mothering three children, ages 15, 13 and 5. "Learning is never dull," she writes. Neither, it seems, is her life.

**Ellen Cohen Clarkson** recently authored *Six Acts on a Flying Trapeze* for Prentice Hall. It is a text for English as a second language, and the title alludes to moments "when the student dares to let go and experience the thrill of a new world."

**Linda Roth Futterman** presented a paper this November at the 4th Annual Conference of the Center for the Study of Anorexia and Bulimia. Husband Stanley is now a partner in the law firm of Epstein, Becker; son David, a junior at Williams, is studying abroad in London; son Danny is a freshman at Columbia, and son Matthew is a junior at Mamaroneck High School.

**Linda Benjamin Hirschson** has been elected to the Board of Trustees of the Calhoun School in Manhattan. A tax lawyer, she is a partner in Gilbert,

Segall and Young and also teaches law at NYU as an adjunct. Her son is a freshman at Brown and her daughter is a sophomore at Riverdale Country Day School.

**Susan Huhn Eustis** has formed a new consulting firm in Lexington, MA. She intends to sell studies about patents in computers to corporations.

**Rusty Miller Rich**, mother of two, still lives in Detroit where she is subbing in city schools and is actively involved in peace causes for Ethiopia and other countries. (She organized a fast for Oxfam and brought an Ethiopian missionary to talk to local groups.) As Barnard Area Rep, Rusty is active in alumnae activities and hopes to see others at Alumnae College in May. Husband Rich is still teaching at Wayne State and is active in Black causes.

I am still free-lancing, editing several advertorials for *The New York Times* on Health Care and Education, teaching a course at NYU, and constantly busy with writing projects for a variety of magazines and newspapers.

This December, I had the unexpected delight of visiting with **Irina Shapiro** and her father on their trip to Manhattan. Irina looked wonderful—she has a 16 year old daughter and enjoys teaching Russian studies at the University of Minnesota in Minneapolis.

After all this buoyant news, I have to relate a recent tragedy. Last June, **Andrea Ostrum** and her companion, Stanley Kooper, were in a terrible car crash. Stanley was killed instantly and Andy is still in a coma that is unlikely to change. Andy's children, Eva, a senior at Yale, Ethan, a sophomore at Wesleyan, and Judah, a senior at Hunter High School, have been with her constantly. Those of you wishing to send cards, letters or flowers may write: The Riverside Healthcare Center, 745 Main St., East Hartford, Conn. 06108. "Andy would be really proud of her children," Ruth Nemzoff told us. "I know they would appreciate letters."

**63** **Wendy Supovitz Reilly**  
Box 1031  
Sea Island, GA 31561

**Anne Broderick Zill**  
2312 19th Street, NW  
Washington, DC 20009

Seventeen classmates attended the "mini-reunion" on December 8th. From the metropolitan area were: **Carol Miles**, **Lois Lempel Weinroth**, **Judy Rothgart MacDonald**, **Iris Unger Friedlander**, **Marian Mandel Bauer**, **Merilee Peterson Obstbaum**, **Charlotte Alter Spiegelman**, **Linda Sweet**, **Terrie Erlich Polovsky**, **Pola Auerbach Rosen**, **Loretta Tremblay Azzarone**, **Carol Mayer Solomon**, **Caroline Fleisher Birenbaum**, **Claire Gottfried Holzman**, **Sheila Gordon**, **Linda Rolnitzky** and **Sharon Flescher**. Sheila, Linda and Claire spoke about their careers, and good fun, talk and wine were shared by all. Barnard prepared a wonderful buffet, and one classmate noted, "At least the food has improved since we left campus."

Suggestions for future get-togethers were: Continuing the current career-oriented talks by classmates (especially focusing on the transition from academia to the corporate world); organizing focus-group sessions on topics of mutual interest such as life-stages, money pressures as they relate to women and job choices, and an all-day Sunday retreat at Holly House. Another mini-reunion is scheduled for Friday evening, May 16 as part of the non-reunion classes dinner at Barnard. If you haven't already reserved a place by returning the form on the Reunion brochure, do it now!

**Judy Bennett Bantz** has moved to San Francisco to become creative director for Dancer Fitzgerald Sample Direct. **Barbara Levitz Hankin** is attending law school but hopes to attend the next mini-reunion with degree in hand. **Sharon Flescher** has moved back to New York to join WNET/Channel Thirteen. Her position involves dealing with corporations who would like to underwrite/sponsor public tv pro-

## In the News



**Tisa Chang '63** has spent most of the last 25 years on and off-Broadway — at Barnard, in the theater, and, since 1977, as artistic/producing director of the Pan Asian Repertory Theatre.

As a performer, Tisa Chang spent several years in "union contract work from Broadway to stock to grade Z night clubs, to a Hollywood film to 'under 5's' on soaps." Too often she found herself in stereotypical Asian-American roles, and she realized that she would continue to be typecast if perceptions of Asian Americans were not changed. If no one was producing or writing non-stereotyped roles for Asian Americans, she decided, they would have to create opportunities for themselves.

In 1973, under the auspices of Ellen Stewart at La Mama, she adapted and directed *The Return of the Phoenix*, a Chinese Peking Opera using traditional movement and music. It was a success, and she went on to produce six more adaptations before founding Pan Asian Rep.

Pan Asian Rep annually presents four professional productions, in English. It has a core of about 40 Asian-American actors, directors, designers, and playwrights, who rely on the company for the opportunity to do challenging projects. Only half of the group are full-time actors; the rest have other jobs, outside the theater. Tisa Chang's goal is to have a truly professional company, "in the sense that you can make a living at it, as a full-time endeavor."

In addition to its growing audiences, the company receives funding from the New York State Council on the Arts and from NEA, and last year received a grant for institutional development from the Ford Foundation. Its repertoire includes Asian, Asian-American, and Western plays. Tisa directs some of the plays, but much of her time is devoted to administrative work, including creation of a midwestern Asian-American company (since Pan Asian Rep is the only one east of the Rockies). She also goes back to acting from time to time, and was seen most recently in the Michael Cimino film, *Year of the Dragon*.

grams, and she would welcome suggestions of companies. A long article she wrote on Manet's "Olympia" appeared in the *College Art Journal*.

**Linda Holzman Creason** has been employed by Hughes Aircraft for the past several years. During employment with Hughes she obtained her master of science in computer science and is now a staff engineer/technical supervisor. She married James Creason in 1985 and had a daughter, Jamie Lynn, in December who joins Linda's two other daughters, Lisa 15, and Brandi 13 — a possible three more alumnae for Barnard.

The class has established a scholarship fund in honor of our deceased classmates as our 20th Reunion class gift. Anyone who wants to contribute should write "Class of '63 memorial scholarship

fund" on the check and also mention a particular classmate's name if desired and Barnard will send a note to the family acknowledging the special tribute.

Last July, **Stephany Smith Sechrist** served as a workshop leader for the first conference of the Network of Biblical Storytellers held in Maine. The theme for the conference was "Telling the Stories of Peace." Stephany's workshop involved dramatic/liturgical reading of the New Testament Book of Revelation and consideration of the book's use re: the issues of violence, peace and the arms race.

**Marlene Lobell Ruthen** continues to work as an illustrator. Book number 10, written by her husband, is due for publication in the spring. Future books are on the drawing board, including one written by **Barbara Friedberg Bar-Nissim**. Her oldest child, Russell, is a sophomore at Cornell, and her daughter Paula is a junior in high school. Marlene finds it incredible to have college age children when it seems just yesterday she had to face college registration herself.

**Naomi Schor**, a member of the Brown University faculty in French Studies, will be conducting a summer seminar sponsored by the National Endowment for the Humanities this year. Her subject is "Woman and Representation in 19th Century Fiction."

—WSR

# 64

**Donna Rudnick Lebovitz**  
1128 Green Bay Road  
Glencoe, IL 60022

**Judy Lefkowitz Marcus**  
33 Elizabeth Road  
New Rochelle, NY 10804

We have been notified of the death in January of this year of **Doris Seiler Heyman**. Our sympathy goes to her husband Joseph and her family.

**Gray Wilson** is living in the Appalachians with her Swiss-born husband, Charles Cardinaux, and their two year old son. For over ten years she has been a "poverty lawyer" working primarily with federally funded legal service programs. She writes of her delight in finding **Alison Guild** alive and well and living in Colorado with her husband, David Olof, and their two sons.

**Carol Berkin** has been made Assistant Provost of Baruch College, "a new, scary — but exciting — career shift." **Sharon Block Korn** is an accountant for Arthur Young & Co. in their Entrepreneurial Services Group, which serves small businesses and their executives.

**Linda Vaughn Fitch** leads workshops on creativity, communication, and change. Her unique counseling approach combines concepts from transactional analysis, gestalt, neurolinguistic programming, and the expressive arts therapies.

**Susan Kelz Sperling's** third book, her first for children, was published in Oct 1985. *Muffles and Wink-a-peeps: Funny Old Words for Kids* expresses Sue's abiding delight in language and her continuing efforts to develop language skills as a basic element in the total educational process. Her son Matthew continues to hone his skills in the freshman writing program at Harvard.

**Merilee Rosenberg** and her new husband, C. Seaburn Little, proudly announce the birth of Lili Rebekah and Jonah Gabriel Rosenberg-Little on February 23, 1985. **Marian Pollett Leighton** is also a proud new mother. Adam Matthew was born October 29, 1985, joining siblings Melanie (a freshman at the U of VA), Russell, Valerie, and Kimberly. Marian combines parenting with working for the Defense Department.

—DRL

# 65

**Patricia Zimmerman Levine**  
1115 Country Club Drive  
Bloomfield Hills, MI 48013

Congratulations and best wishes for a long and happy life together are in order for **Margery Dubrow**

and Daniel Mansolino, who were married on August 9, 1985 in North Eastham, Cape Cod, MA.

**Mary Lee Keats Morris** writes that she received her PhD in Romance Languages from Fordham University in 1970, taught for 12 years at Cathedral College, and is working for a Garden City law firm, having passed the July 1985 bar exam.

Martha Munster Links is now **Martha Links Mastroberti**, and her new address is 641 Breton Place, Arnold, Maryland 21012.

**Eileen Parsons** sends word from Oakland, California that she earned her Master of Music degree in vocal pedagogy from Holy Names College in 1983, and this past summer joined the music department there. In September, Eileen appeared as the Princess de Bouillon in Eugene Scribe's *Adrienne Lecouvreur*, presented as part of the "Opera's Dramas" series at the Hillbarn Theatre in Foster City, California. Eileen writes that this was her first experience with a role in a "straight" (non-musical) play, and that she found it most enjoyable.

**Miriam Victory Wagner-Spiegel** has sent her classmates best regards and lots of news. Vicky moved to Europe in 1980, after working for eight years as a project director at the Community Council of Greater New York. In West Berlin, Vicky taught social work and was involved in several community organization projects for three years, at which time she moved to Switzerland to be with her now-husband, Antonin Wagner, who is an economist and Dean of the School of Social Work in Zurich. Vicky reports that her 14 year old stepdaughter, Ruth, who lives with Vicky and Antonin, is a source of great joy in her life. Although Vicky is not yet working, she is keeping busy with and is stimulated by her new interests which include her volunteer work with Amnesty International and on behalf of political refugees in Switzerland; her training in three simultaneous programs — transactional analysis, neurolinguistic programming, and theme-centered interaction — designed to help Vicky establish herself in her new home; working with groups and individuals on communication and other interpersonal problems; and occasional joint projects with her husband such as the paper they delivered together at the Congress of the International Association of Schools of Social Work held in the summer of 1984. Please note Vicky's new address: Breitenstrasse, 8914 Aeugst am Albis, Schweiz.

Levine's List of Missing Classmates continues: **Elaine Levine, Penelope Wilson Fiske, Rachel Freeman Steiner, and Nancy Antell Sussman** — where are you?

For those of you who honestly believe that the world is flat and ends west of the Hudson River, we do have the Pony Express out here in Michigan, and any news you send will be cheerfully received and included in a future column.

# 66

**Anne Cleveland Kalicki**  
8906 Captain's Row  
Alexandria, VA 22308

An open letter to all Classmates who have decided NOT to come to our 20th Reunion because they are (circle one) not working, not mothers, not married, not heterosexual, not feminist, not Democrats, not well, not nearby and/or not interested. . . Dear Not: You think you've got problems. I am so depressed. I've been out of work for five months (eight by the time you read this, unless lightning strikes) and going loony, doubly loony since I'm not writing the Great American anything will all this "free" (job-hunting) time — I'm talking 80 applications, a dozen interviews and empty-handed here. I'm not married (that's the good news). I'm sort of not a mother (he's living with his father). All right I am heterosexual, but I'm also a feminist and a Democrat — depression city nowadays. Please don't stay away just because you're not corporate vp yet; come cheer me up (better yet, come offer me a job). Come tell me I should have had six kids and lived on a farm. Come tell me what it feels like to be a dancer or an accountant or an ex-con. I mean I'm trekking all the way up there in a car that rattles the brains starting at 40 (rather

the way life does, actually). So y'all come, too, heah?

One classmate who is looking forward to attending reunion is **Mary Siegel Bleiberg**, a one-time history major, now Director of Program Development for the City Volunteer Corps, a new NYC agency created last year. The agency hires 17-to-20 year olds who want to give a year of service to the community, in a full-time program for dropouts, high school graduates, college students, etc. Mary is also developing a Junior Year service program for college students. She is hiring college graduates as team leaders and is interested in those with Peace Corps or other community service experience. Her work number is 212/475-6444. Time is passing, folks: Mary's daughter is applying to Barnard this year.

Another New Yorker, art history major **Nancy Levitt Hoffman**, has for 13 years promoted the work of contemporary American artists at the Nancy Hoffman Gallery. This spring she was juror of the 28th Irene Leach Memorial Juried Exhibition which is showing at the Chrysler Museum in Norfolk, VA from April 18 to June 1. The show exhibits works by artists from Virginia, Maryland, North Carolina and the District of Columbia.

Economics major **Barbara Insel** of New York received a \$5000 "World Hunger Media Award" for an article in *Foreign Affairs* entitled "A World Awash in Grain." The award was presented at the United Nations in November. Congratulations, Barbara!

If my records are accurate, this is the first news we have heard in ten years of these three enterprising New Yorkers. I hope that non-scriveners and the faithful who have been the backbone of this column alike will make it to Reunion May 16-18. See you there.

A couple of notes received in the Alumnae Office: "There is a tremendous need for legal assistance to help people get and keep benefits to which they are legally entitled," according to attorney **Toby Golick**, who is working to fill that need as director of the newly established Cardozo Bet Tzedek Legal Services, at Yeshiva University's Cardozo School of Law.

Although students have to take special courses as background, Toby says the best education in this area of law comes from helping people in need. Before becoming the program's first director, Toby was senior attorney at Legal Services for the Elderly for over ten years.

**Bonnie Dickes Fraser** spoke on the topic of assertiveness to the Hudson (OH) Kiwanis last October. Bonnie, who has a PhD from the California School of Professional Psychology, works as a psychologist for Western Reserve Human Services in Twinsburg.

**67 Nancy Shapiro Kolodny**  
34 Dan's Highway  
New Canaan, CT 06840

**Alice Kerman De Lucia** wrote, "After eleven years of teaching foreign languages, I'm currently keeping very busy taking care of my two daughters, Laura 3 and Christine 16 months. My husband, Michael, was recently made a partner in his law firm." They were hoping to do some skiing this winter in the White Mountains.

From **Susan Silverman Garelik** we hear, "I'm alive and well after 17 years of marriage to Michael (now a compensation consultant), two daughters—Liza 9 and Jane 6—and a master's in nursing. I practice part time now in ICU and am involved in Girl Scouts, synagogue, and survival in the suburbs."

**Elizabeth Kramon Harlan's** second novel, *Watershed*, will be published in May by Viking. She is a fiction student in Columbia's MFA in Writing program.

**Sandra Wolman Moss** is an internist at the Rutgers Community Health Plan in New Brunswick, NJ. She is also clinical assistant professor at the College of Medicine and Dentistry of New Jersey and Editor of the Journal of the Central New Jersey Medical Group. Her husband, Robert Moss, is professor of chemistry at Rutgers and Associate Dean of Natural Sciences. Their two sons are now ages 6 and 12.

## In the News



A great deal of public attention was focused last year on the world hunger crisis and efforts to relieve it, and the fourth annual World Hunger Media Awards recognized those who had publicized it. Among the honorees was **Barbara Insel '66**, whose article entitled "A World Awash in Grain," published in *Foreign Affairs* (Spring '85), earned a \$5000 prize.

Barbara is a global market strategist who was an International Affairs Fellow at the Council on Foreign Relations. After earning a master's in economics at Brown and an MBA at Stanford, she had worked on a variety of projects for the World Bank: evaluating and negotiating commercial projects in India, Philippines, and Syria; managing and monitoring investments in several African countries, and supervising 300 project staff in Brazil as well as negotiating the restructuring of agricultural, banking, and policy targets.

At the Council on Foreign Relations, she devel-

oped a radical new approach to commodity markets, focusing on the changing competitive structure. In her article for *Foreign Affairs*, she sought to demonstrate that "agricultural policy will never again be only a domestic issue—or only an agricultural issue."

Over the past ten years worldwide production of wheat and feed grains has grown faster than population, largely as a result of improvements in technology, but also because of incentives for production. While the number of exporting nations has grown, the importing market has shrunk, so that the U.S. is "essentially competing with its close friends to sell (grain) to a smaller number of less-good friends." And these trends are likely to continue, with further increases in world supply and relatively minor growth in demand.

"All the major exporters are looking to the developing countries as a major outlet for their surpluses," but the agricultural potential of East Asia and Latin America must temper any such expectations. Even the famine in sub-Saharan Africa, she notes, suggests the need for long-term development of infrastructure and human resources, not an agricultural production crisis. The cost of financing the whole shortfall of 3-4 million tons would have been "barely a footnote" to U.S. export credits and food aid, and would hardly have dented the world's surplus stocks of nearly 190 million tons.

"Any unilateral action to try to manipulate the global market," she points out, "is almost certain to be self-defeating. . . unless policy-makers consciously attempt to stop the cycle, define their objectives more clearly and find new ways to achieve them."

**Laura Feldman** is interested in meeting other alumnae in the Chicago area. She is an academic radiologist working at the University of Chicago Medical Center. Laura and husband Roger Boshes, a psychiatrist, and children Evan 6 and Erica 2 live in Glencoe, IL.

**Esther Hoffman Weinstein** is an instructor of keyboard at the Nevada School of the Arts, and of keyboard and music appreciation at the University of Nevada/Las Vegas. She also produces "Concert Preview Series" on KNPR, Las Vegas's public radio station. In addition, she works as a writer, specializing in music, and it was an article on "piano lessons for grownups" in the *Las Vegas Review-Journal* which brought her to our attention.

**68 Barbara Prostkoff Zimmerman**  
436 S. Olive Way  
Denver, CO 80224

**Abby Sommer Kurnit**  
85 Stratford Avenue  
White Plains, NY 10605

The holiday season is always a good one for catching up with "lost" folk. For some people the yearly card is the only communication one has. This year it brought greetings from **Anna Smullen** who congratulated me on my son's birth and told me her son was 16! She is the head librarian at Chadbourne and Parke, a law firm. Thanks, Anna, it was lovely to hear from you after all these years.

The new year also brought a phone call from **Jane Wallison Stein** who, along with her two comely daughters, is happy and healthy and living in Brooklyn Heights.

"A busy year!" is how **Irene Herz** describes 1985. On October 5, she married Duane Tiemann, a staff systems analyst for Trintex in White Plains. Irene is a systems analyst at Blue Cross/Blue Shield of Connecticut. They were planning to move into their new house in Trumbull in December.

My husband Jeff ('68C) and I went into Manhattan a few weeks ago and stopped by Gregory's, a jazz club owned and operated by **Alicia Sherman Silver '71** and her husband Norman. Not only is it a pleasant place, but Alicia is a wonderful performer with a diverse repertoire of standards and new material. If you have the urge, stop in—it's on First Avenue and 63rd St.

A considerable time before that, **Elizabeth Good Fisher** wrote me a nice long letter outlining her adventures since graduation (which was, heaven help us, almost 20 years ago—better start making plans for two years hence!). She lives in Connecticut and has been married for 19 years. She and her husband Josh have two children ages 4 and 8. After Josh received his PhD in computer science six years ago they quit the Manhattan merry-go-round for the commuter circus, Elizabeth from Darien to Manhattan and Josh from Darien to New Haven (Yale). It is no wonder that that existence was too hectic, particularly as one adds in two children, so they all moved to the New Haven area where life settled down to a more pleasant pace. But, as we all have learned, life is not that simple. Josh left Yale to start a business and, as Elizabeth puts it, has undergone "a truly startling metamorphosis" from academician to businessman. To complete the cycle, Elizabeth has gone from business back to academia and is now in the second year of an MBA program. Add to that family and home management and you have a life that is not in the least bit placid, as many of us will attest to.

And what am I doing? Teaching, parenting, performing, shopping, cleaning—all the usual things. With the coming of spring and sunlight at the end of the long winter tunnel things always seem brighter. I trust that is true for all of you.

To close, may I quote Elizabeth? "I enjoy reading the *Barnard Alumnae* Magazine and hope that others of our classmates heed your semi-annual pleas for news." Well, heed them. . .

—ASK

Carol Stevenson Harlow  
Box 24167  
Denver, CO 80224

Lynne Spigelmire  
21 Cypress St., Apt. 3  
Brookline, MA 02146

**Barbara Falk Sabbath** wrote in December that she is a clinical psychologist with an appointment in the Department of Pediatrics at Yale and a private practice in New Rochelle, NY, after a short stint in a philosophy program at MIT, followed by a few years of teaching kindergarten. Her good friend is **Annie Farber**, formerly an anthropologist, now a lawyer, and also a resident of New Rochelle. Barbara and Annie, who did not know each other at Barnard, met through their children: Barbara's daughter Kate and Annie's twins, Emily and Rachel, are best friends, "the way nine year olds can be," writes Barbara. Annie and her husband, Richard Kaiser, also have another child, Deborah.

Barbara also reports that she is still in touch with her Plimpton roommate, **Kathy Shenkin Seal**, who spent eight years working in a GM factory in California, and remains a politically active free-lance writer. Barbara visited Kathy, her husband Jim, and her sons Jeff and Zack in Santa Monica last summer, and the Seal family had plans to visit Barbara's family last Christmas.

**Monique Raphael (High) Raiport** sent news of her marriage, on November 10, 1985, to Dr. Gregory Raiport. "Grisha" is from Rostov, USSR. He graduated from the Rostov State Medical Institute, and served as psychologist for Russia's 1976 Olympic Team in Melbourne before defecting to the US. His specialty is enhancing the performance level of people under stress. Monique's latest novel, *The Rock and the Flower*, is scheduled to be published by Delacorte Press early next year.

**Judith Kopecky Starr** wrote that she is married and the mother of three-year-old Robin. Judith was recently elected to her town's representative town meeting. **Leslie Kadis Glode** moved back to the Oregon coast after a number of years inland. She is feature editor of the *News-Times/Lincoln County Leader*, a Newport, OR weekly. Her husband Dan practices law in Newport, and her sons Christopher eight and Jeremy four enjoy the beach and the variety of activities in Newport. "The transition from social work to journalism has been a good one for me," writes Leslie.

**Karen Robertson** is an assistant professor of English at Vassar College.

**Martha Gaber Abrahamsen** wrote a long letter from Warsaw, where she and her husband, a counselor at the Danish Embassy there, are stationed. Martha notes that her six year old son is "becoming partly Americanized, sometimes to my delight, sometimes to my horror." He attends the American School of Warsaw. Martha co-chairs a women's group studying Polish literature in English translation, and translates from Finnish, Swedish, Danish and Norwegian into English. She also entertains and is entertained "at various diplomatic functions, which involves more than just mindless cocktail babble, and can be fascinating, depending on the people you choose to talk with." Martha and her husband like Poland and the Poles very much and "look forward to another couple of years here." She invites Barnard alumnae to contact her if they happen to go to Warsaw. Finally, Martha asks, does anyone know where **Mary Bellhouse** is?

**Elizabeth Dreifuss Holmes** writes: "I passed the NJ Bar in December and am an associate with a small law firm in Bergen County. My husband, Rupert Holmes, is the author of the book, music and lyrics in a new Broadway musical, *The Mystery of Edwin Drood*, which has received universal rave reviews."

I hope you're all enjoying spring and that you are inclined to write to me with your news of family, work, Barnard friends.

—L.S.

## In the News

When Executive Women of New Jersey held a "Salute to the Policy Makers" in April, they honored 60 women, including three Barnard alumnae, who are directors of major corporate and foundation boards in New Jersey.

**Dr. Rita F. Girolamo '47** is a member of the Board of Directors of First Jersey National Corporation. She is vice-chairman of the Department of Radiology and Director of Nuclear Medicine at NY Medical College, where she is also president of the Alumni Association.

**Marilyn Gold Laurie '59** is vice president for public relations at AT&T Communications and a trustee of the AT&T Foundation. Her article on opportunities for women in a high-tech society appeared in *Barnard Alumnae* in Summer 1984.

**Jane von der Heyde '71** sits on the board of Grand Union Company. She is a director, senior vice president, and general counsel of G.O. Holding Management Inc., and has served as vice president and general counsel of Cavenham Holdings, Inc., the parent company of Grand Union.

## 70

Bonnie Fox Sirower  
69 Godfrey Terrace  
Glen Rock, NJ 07452

I don't really believe that no news is good news... so I'll include the few items I received from my fellow classmates this quarter and hope that I'll have more information for next time.

**Alice Sturgis Feinstein** has continued her career in journalism by joining the staff of *The Anderson-Independent Mail*, published in Anderson, South Carolina. A former teacher, Alice has worked as a writer for newspapers in Pine Bluff, Arkansas and Spokane and Seattle, Washington. Before undertaking her new position as Education Editor, she served as religion and education writer for the *Chronicle* in Seattle. Her husband Philip is a freelance photographer and artist.

According to the *Holyoke (MA) Telegram*, **Susan E. Rosen** recently began working at the Valley Health Plan's Health Center in Northampton as a family physician. Before earning her MD degree from UMass, Susan received a bachelor of science in nursing from Columbia and worked as a nurse for public health clinics and a visiting nurse association.

**Rose Distenfeld** writes that she has finally taken the plunge and moved to suburbia. One of her new re-acquaintances is **Helene Schorr Wallenstein**.

**Audrey Gale Prager** wrote that this time she *really* has something to contribute to Class Notes. Her son Joshua Aaron was born in October. He made his appearance a bit ahead of schedule, but has caught up quite nicely, thank you. Her husband Steve and she are enjoying the new experience of parenthood. Muses Audrey, "I'm still not accustomed to thinking of Joshua's care as an accomplishment, and hence there are days that I feel frustrated because 'I didn't get anything done.' Taking care of an infant is itself an accomplishment!"

Last April, Audrey started her own direct marketing company, Gale Marketing, acting as an agent for clients who want to mount marketing campaigns using telephone or mail with a direct response mechanism. She works the business out of her home, which allows her some flexibility and leaves her time to spend with Joshua.

As for my own activities, I've just taken the plunge back to full-time employment. My new employer is a home for disabled adults. As usual, my job is to raise the funds to help run it. . . . So far, I'm not finding juggling the kids, the job, and the mar-

riage too demanding, but there *are* the inevitable nights when both husband Marty and I have a meeting. The key is being flexible!

Hope to hear from all of you soon!

## 71

Julia Hong Sabella  
186-26 Avon Road  
Jamaica Estates, NY 11432

Rose Spitz Fife  
630 Sugarbush Drive  
Zionsville, IN 46077

News is sparse this issue. **Carla Wengren Ricci** wrote that she is Associate Dean for Research at Tufts and is "busy developing and working on major projects in Africa and in China."

Difficult as it is to believe, this year is our fifteenth Reunion. We hope everyone will try to attend. See you May 16 and 17.

Please send more news! Your classmates would like to know what you are doing.

—RSF

## 72

Marcia R. Eisenberg  
302 West 86th Street, Apt. 8A  
New York, NY 10024

Ruth B. Smith  
10 Dana Street, Apt. 307  
Cambridge, MA 02138

Greetings from NYC. **Rose Yu Chin** dropped off a note about her doings at the Alumnae Office recently. She and her husband, Andrew Chin, moved from NYC in November '85 and bought a house near Ridgefield, CT. Rose has changed jobs: she was the Director of Community Support System Psychiatric Clinic at Roosevelt-St. Luke's Hospital; she is now the Medical Director of the Crisis Intervention Program at Danbury Hospital. Andrew has continued at his NY business as well as continued his abstract painting in their new loft. Rose is excited with her city-country move, the challenge of building a new clinical department, and with the prospect of starting a family.

A news clipping reports that **Christine Jelalian** has joined the medical staff of Roosevelt-St. Luke's Hospital. Her specialty is plastic and reconstructive surgery. Christine received her medical degree from New York Medical College in 1975, and did research, training and fellowships in renal transplantation, plastic surgery and hand surgery. She is an assistant professor of surgery at New York Medical College and lives in Newburgh, NY.

**Barbara Naomi Cohen** wrote in that she has been the editor of "Performing Arts Resources" for the past five years and recently published a book (as a co-editor) entitled: *Preserving America's Performing Arts*. She says she uses the name Barbara Stratyner because there is another Barbara Cohen who is also a Barnard graduate, an active writer as well as an Authors Guild member.

**Lisa Schnitzer Plavin** conducted a workshop for synagogue and Jewish school librarians at the Greater Hartford (CT) Jewish Federation in October. Lisa is the librarian of the Solomon Schechter Day School in West Hartford, and received her MLS from Rutgers.

**Rebecca Newberger Goldstein**, assistant professor of philosophy at Barnard, published a short story, "The Legacy of Raizel Kaiddish," in *New Traditions*, October 1985. Another piece, "The Boarder," appears in a collection called *First Loves*, published this spring.

A note from **Linda Hart Butler** tells what she's up to: "John and I had our first child, Peter Jefferys Butler, last May, and our eyes are open to the overwhelming wonders of parenthood — both its joys and troubles. It seems there's no way to prepare oneself adequately for that state. John works on our house to build us a baby's room, and I for our bread and butter, still at market research."

**Elizabeth Marlin Legatt** and family have moved to

White Plains from NYC. Elizabeth is in private practice in obstetrics and gynecology in Port Chester; husband Alan (E'72) will be an assistant professor of neurology at Einstein College of Medicine in the Bronx. Their sons are Michael 7 and Joel 3.

**Elizabeth (Liz) Bothamley** was appointed in August '85 as Associate Director of Admissions at Barnard. She is in charge of the Freshman Program. After leaving Barnard (and she sent a note to say how excited she was to be back) she had received a PhD in educational sciences from the University of Navarre; taught and did administrative work in various high schools; served as Director of Admissions at two private schools; and served as Headmistress at Montrose School in New England.

The Alumnae Office sent along a copy of notepaper from **Francine Castellucci** which shows that she is a licensed practicing psychologist in North Carolina. No other news from anyone else.

I am looking for a new job and haven't figured out what I want to do this job change — which makes it sort of hard. I am also still getting used to being a four person family. Some days the logistics can really get to me — and I excel at organization. But, it is fun and seems healthier to balance the debates over which public school Dana should go to with the excitement of Merle's first words. Please keep writing — bye for now.

—MRE

73

**Ilene Karpf**  
7 Fenimore Drive  
Scotch Plains, NJ 07076

**Catherine Dwyer** spent two years as group counsel for the Financial Services Group of Automatic Data Processing, Inc. She was recently promoted to vice president-corporate development for ADP, a nonlegal position where she has responsibility for merger and acquisition activities. Kate's husband, Terence Blackburn (L'73), is president of Continental Properties Corp., a real estate syndication business. They have two children, Brandon and Allegra. Since 1980, Kate has been an adjunct professor at Seton Hall Law School. In her spare time, Kate is busy fixing up her family's old house in Montclair, NJ.

**Kim Haley** received her MBA from Columbia and is an Asst. Brand Manager in the Desserts Division of General Foods Corp.

**Wendy Greenberg** was promoted to assoc. professor of French at the Allentown campus of Penn State. Wendy received her PhD from Columbia and is the author of *The Power of Rhetoric* and numerous articles published in academic journals.

In its review of the year's best achievements, *New York Magazine* named **Laura Brevetti** as "The Best Prosecutor" for her work on the Organized Crime Strike Force in the Eastern District of NY (Brooklyn). Laura has been investigating the causes of the structural problems in the infamous 63rd Street subway tunnel. She was also named Young Federal Lawyer of the Year by the Federal Bar Assn.

**Patricia Levin Grossman** is kept busy by her four children, Joel, David, Jacob and Debra. She is also president of her Temple's Sisterhood. Patti and her family have been living in the Boston area for eight years.

**Irene Sawchyn's** baby, Melania Christina, was born on Christmas 1984. Irene has been working part-time in the Advanced Technology Planning Dept. at Bell Labs since Melania's birth.

**Linda Joselow** is also a new mother. Linda's baby, Samuel Straw, was born in December 1985. After a brief maternity leave, Linda was planning to return to Compton Advertising.

My Plimpton suitemate, **Beth Lipsey**, is now creative director at a large Boston advertising agency. Beth and her husband Kevin McCabe have bought some land in Maine where they hope to escape on occasion.

**Roberta Israeloff's** book, *Coming to Terms* was recently published by Penguin. It discusses a

woman's feeling concerning motherhood.

**Jenna Weissman Joselit** was the curator of a recent exhibit at the YIVO Institute for Jewish Research which focused on Jewish Mutual Aid Societies from 1880-1950. The exhibit was discussed in a lengthy article in *The New York Times*, in which Jenna was prominently featured.

**Judith Sokolow** is a founding member of Medivideo, Ltd. which won a DuPont/Columbia U. Award for Broadcast Journalism for its documentary, "Whispering Hope: Unmasking the Mystery of Alzheimer's." Judy was responsible for camera work and editing. The film has also been the recipient of various other awards, including two Emmy nominations. Having had personal experience with Alzheimer's (my grandmother is a victim), I can fully appreciate Judy's efforts.

*Columbia College Today* recently published an extensive interview with **Jerrilynn Dodds**, who is an asst. professor of art history at Columbia, specializing in medieval and Islamic architecture and art. Jeri received a PhD from Harvard and taught at U Minn., UNC, and Duke prior to assuming her position at Columbia in 1980. She also directs the Columbia College program in art humanities and participated in the formation of the Panel on Sexual Harassment at Columbia. Jeri has received fellowships from Fulbright-Hays and the National Endowment for the Humanities. Her husband, Charles Gifford, is an architect and they have a child, Sanford Robinson.

Another Plimpton suitemate of mine, **Janet Axelrod**, is Vice President of Human Resources at Lotus Corp. in Boston. She was quoted in a recent *New York Times* article concerning the introduction of nutritious food into company cafeterias.

**Rena Seplowitz** writes that she is an associate professor at Touro Law School, where she teaches trusts and estates, estate planning, intellectual property, and legal history.

**Marian Sabety** recently married James P. Wieghorst; they live in Mountain Lakes, NJ. Marian is marketing director of Digital TranService Corporation, a digital telephone network provider for multi-tenant buildings nationwide.

74

**Dr. Catherine Blank Mermelstein**  
8 Patriot Court  
E. Brunswick, NJ 08816

I was relieved to receive so much news from classmates in the last months. I had already exhausted my own personal supply of gossip for the previous column.

**Anna Quindlen** and Gerry Krovatin (CC'74) became a family of four with the birth of their second son, Christopher Krovatin. Their first son Quindlen is two years old. Anna has left her job as a reporter and editor at *The New York Times* to write a novel.

Anna wrote to bring our attention to two distinguished classmates. **Susan Schnur**, a rabbi in New Jersey, recently wrote for the "Hers" column for the *Times*. **Maureen Killacky** is a gynecologist at St. Luke's-Roosevelt Hospital.

**Jo-Ann Reif** wrote in the most elegant of handwritings to say that she is a tutor in the musicology department of the University of Zurich. She is also active in the American Women's Club of Zurich to whom she is giving a number of colloquiums on topics of music history.

**Miriam Newman** and her husband Michael Pinolis announce the birth of their first child Joshua on September 30th. Miriam keeps herself busy mothering and doing volunteer work for Action for Soviet Jewry.

**Diane Fenner Zwillenberg**, the mother of three children under age six, is an attorney at Pepper, Hamilton and Scheetz in Philadelphia. She wonders what has happened to **Susie Bass**. Susie — please write to me with an update.

**Amy D'Avita** has been named head academic counselor for Pace University's new Academic Skills Advisement Center. Prior to this Amy has taught linguistics, English as a second language, and speech in the City University system.

**Rachel Hendrickson** reports that **Mary Krueger** and Peter Sullivan (CC'74) are happy and healthy, living in Los Angeles and enjoying their twin baby girls, Hillary and Caroline.

**Linda Bernstein** is on leave from her teaching position at Queens College because she and her husband, Dr. Howard Rutenberg, are expecting their second child before the spring semester ends and shortly before the third birthday of their son Raphael Isaac.

Thanks to **Michelle Friedman Belfer** for all her help. I hope to hear from many of you soon.

75

**Diana Karter Appelbaum**  
2 Hampshire Avenue  
Sharon, MA 02067

**Hannah Kliger** writes from Amherst where she has recently been appointed Asst. Prof. of Jewish Studies and Adj. Asst. Prof. of Communications at U. Mass. She received her PhD from Penn; her academic interests are in Jewish social research and the sociology of communication. To quote from her letter, "I appreciate the atmosphere that Barnard provided for me, and all of us, to pursue our interests and our dreams."

**Wendy Chambers** is successfully pursuing her dream of composing music in New York where one of her pieces was performed by the East Coast Brass Quintet at a recent Artmusic benefit.

**Diane Cecilia Carlson** confesses that she has not written in all the years since graduation. During that time she earned an MA in French Lit., worked in a French bank, and taught in Switzerland, before settling in Concord, Mass. with husband Alan, a Boston attorney. They have two children, Julia 4 and Philip 2; Diane is teaching Julia to speak French. She also finds time to pursue interests in quilting and drawing. Having decided not to work at a paying job while the children are young, she describes herself as "doing things one at a time — to maintain sanity."

Diane keeps in touch with fellow French major **Sue Weinberg**, an attorney who, after practicing in Washington, DC for some years, is now teaching law in Paris.

**Katherine Jungreis** is home from a trip to Australia where she went camping in Tasmania. When not traveling in exotic places, Katherine is a psychiatric social worker who lives on Beacon Hill and practices in a community mental health center. She is working toward a PhD at Simmons. There are only eight students in her class, and one of them turns out to be **Regina McCaffery**.

Katherine is in touch with **Pat Loudis**, who practices neurology in Philadelphia, and with **Veronica Eckmann Reich**. Veronica lives in Stamford, Conn. She has two children and practices law with a Bridgeport firm.

**Cheryl Kovacs Warner** is an internist at the Harvard Community Health Plan. After med. school at Harvard she trained at Mt. Auburn Hospital in Cambridge. Husband Don is a Boston architect, they have a 2½ year old daughter, Rebecca. Of her roles as mother, physician, and administrator at the Health Plan, she says they are "all hard — harder than I ever imagined," but she would do it all again.

Cheryl is in touch with fellow Harvard classmates **Nan Goldstein Link**, now a psychiatrist in San Francisco, and **Arlene Bradley**, a cardiologist and researcher at Peter Bent Brigham Hospital in Boston.

**Isabelle Wilkins** married Charles Levenback in August 1984, and they have a son Samuel Isaac Jules Levenback born in August 1985. In July of this year she will join the faculty of Mt. Sinai Hospital/Medical School in the ob/gyn department.

**Judith Weisman** writes: "Having finished my residency in general surgery in July 1985 at St. Luke's, I'm doing a one-year fellowship in colo-rectal surgery at Nassau County Medical Center. Our son Gabriel George was born on January 27, 1985 and is a delight. We're in close touch with **Diane Tabakman '73**, whose daughter Jennifer is just 16 days younger than Gabriel. I'd like to hear from **Anna McGowan**..."



Well, my seasonal reminder letter from Barnard informs me that if my year of graduation ends in a 6 or a 1, this is my last chance to reach my classmates before the Reunion. So those of you who have not yet marked down May 16 to 18 on your calendar should do so. I have been wondering about the various thought processes that must be going on on the subject of whether one should actually show up at the Reunion. Some people must find this a very easy decision... but then there are the rest of us. My fantasy is that if one lives in New York the decision is obvious. But then so many of the people I knew at Barnard say that they see no point in going because they knew so few people there and would just feel lonely. The only reasonable response to this I have come up with is that even if one feels a little strange in anticipation of this Reunion, it is probably a great time to meet people (all the others who didn't know too many people), and that this Reunion might be viewed as an investment in the future. If one hopes to go to one's fiftieth reunion and know anyone, then hadn't one better start soon? And who knows, perhaps these events will seem terribly important in forty years.

On the other hand, if you find the above rationale unduly morbid, you could try the "Oh, you will probably have a great time, so just go, and don't worry about it" approach. Or perhaps, "Well, you could go, and if you don't like it—leave."

If you would like to help in these last few days of preparation, you should get in touch with **Andrea Katz Stimmel** at 765-7500 during the day, or at 348-1322 at home (both 212). Also, of the people who have responded to the questionnaire so far, there are more who need housing in New York than have offered to provide housing to others. So if you have space to share with a classmate during the weekend of May 16 to 18, call or write **Pat Tinto Landsman** (718) 646-6620, 1943 E. 27th, Brooklyn, NY 11229.

I recently got a letter from **Susan Madden Hart**—a sequel to last season's meanderings on career versus (or in addition to) motherhood. She writes: "I have been divorced and remarried since Barnard. My husband, Larry Hart, and I live in Wilton, CT, and I have spent quite a few years now as a school psychologist in the Darien school system. My husband and I also share the job(joy) of taking care of our two children—Matthew, born 11/83 and Amanda 6/85. I am very lucky that my husband has his own business and can be with the children while I am at work. It's the best of both worlds!" Susan asks for news of those who were on the volleyball team or who worked at the Barnard Toddler Center.

Also I heard from **Lisa Phillips Davis**, who reports that she has two children—Jason, born in February 1983, and Rebecca, born in May 1985. She is married to Stephen Davis (C '76, C Law '79), is president of the Barnard College Club of Long Island, and works part time as the sales and marketing manager of a small computer systems and software company.

"Father-daughter team takes Northgate project from finance to finish" read a recent headline in the Rockland County (NY) *Journal-News*. The "daughter" is our classmate, architect-builder **Deborah G. Shapiro**, who is developing the townhouse project with her father; they are president and vice president, respectively, of Custom Builders Corp. Deborah has a master's degree in architecture from the Harvard Graduate School of Design and lives in Manhattan with her husband Eric Kurtzman.

**Helene Frieder Lockspeiser** writes: "I have a five year old daughter Dalia (Barnard Class of 2002?) and a 20 month old son Ari. I've been adjunct instructor in psychology at Kean College, Union, NJ for the past seven years, and I've been teaching dance at the Rutgers Hillel Foundation for the past eight years."

A final note, this one about a teacher rather than a classmate: I recently heard from Inez Smith Reid, whom many of us remember fondly from civil rights

## WE NEED YOUR HELP TO KEEP OUR RECORDS UP TO DATE

If you have moved or changed your name, title or telephone number, please send us the new, correct information.

How do you prefer to be addressed? (circle one) Miss Mrs. Ms. Dr. M.D. None

Name \_\_\_\_\_  
first \_\_\_\_\_ maiden \_\_\_\_\_ married \_\_\_\_\_

Street \_\_\_\_\_ Tel. \_\_\_\_\_

City, State \_\_\_\_\_ Zip \_\_\_\_\_

Class \_\_\_\_\_ Husband's name \_\_\_\_\_  
first \_\_\_\_\_ last \_\_\_\_\_

Do you want to be addressed by your husband's name (e.g., Mrs. John Doe)? \_\_\_\_\_

Date of marriage, if new \_\_\_\_\_ Shall we list the marriage in your class news? \_\_\_\_\_

RETURN THIS FORM TO:

Alumnae Records Officer, Room 221, Milbank, 3009 Broadway, New York, NY 10027-6598

class. She is the Corporation Counsel in DC, but this year is a visitor in an endowed chair at West Virginia University College of Law. She reports that she is having a very good year; my West Virginia grapevine indicates that her current students find her as inspiring as we did.

77

**Christine Riep Mason**  
211 Eaglecroft Road  
Westfield, NJ 07090

The Spring issue of *Barnard Alumnae* brings news of marriages and births in the class of 1977.

**Mary Dimaio** was married to Sahibzada Kemal on December 7, 1985 in Brooklyn, NY. Mary graduated cum laude from Downstate Medical Center and is a fellow in pediatric pulmonary diseases at Mount Sinai Hospital in New York. Her husband is a trader with the International Grain Company.

**Michele Halberian** was married to Kenneth Kazarian on September 27, 1985. They live in East Providence, RI.

**Deborah Epstein** was married to Alan Joslin in October 1983. They live in Cambridge, MA.

**Martha Yepes Small** and her husband, Peter, had a son, Alexander Charles, on November 22, 1985. Martha took a four-month leave of absence from her job as a pediatrician at Woodhull Hospital in Brooklyn, NY. Peter is a second-year ophthalmology resident at Manhattan Eye and Ear Hospital.

**Joyce Perlmutter** gave birth to a son, Warren, in March 1985. She is married to Claude Tusk.

**Francine Benzaken Glick** and her husband, Paul, have a 1½ year old daughter, Joelle. Francine works as a staff manager at AT&T.

On the strictly career side, the Alumnae Office reports that **Margaret Broaddus** participated in an alumnae panel discussion on fundraising and foundation work last October. Margaret recently worked with the Visiting Nurse Service and now is on the Development staff at Columbia.

**Tama Janowitz** was one of six young writers to be honored by the General Electric Foundation and the Coordinating Council of Literary Magazines. Her fiction has appeared in the *New Yorker* and *Mississippi Review*.

**Rivka Widerman** graduated from NYU Law School in 1981. "Bummed around a bit after that," she wrote. "Tried to write a book on De La Riviere Manley but got bored with early eighteenth century politics. Clerked for NYS trial judge Murray Myers from 1/83 until 5/85. Now living in DC and teaching legal research and writing at Georgetown U Law Center."

This column was written from newspaper clip-

pings and notes gathered by the Alumnae Office. I haven't received a single letter from our class in over six months. Please write!!!

78

**Jami Bernard**  
41 West 90th St., Apt. A  
New York, NY 10024

SPRING has sprung. At least it's sprung **Susan Mulcahy** from *The Post*. Susan gave the deep-six to *The Post's* Page Six, and now she's giving the high-five to *New York Newsday's* equivalent.

**Amanda Kissin Low**, after a foray into the glitz beat herself, is back to producing her Emmy-winning documentaries for Channel 5.

PARTY NEWS: The best party not to be invited to was thrown by **Lucia Vail** a while back—uninvited guest Carl Bernstein, of journalism and Nora Ephron fame, showed up to play a little piano. I guess Carl figured fame opens doors.

**Carol** and **Abbie Fink's** 30-second lead-ins to American Cyanamid's TV commercials got a big write-up in *Newsweek*. The series of vignettes, called "Intimacies," is the product of the twins' New York production firm and, says *Newsweek*, "sets out to offer viewers small moments of self-discovery as well as hook them for the sponsor's message that follows."

MATRIMONIALY SPEAKING: **Miriam Westheimer**, daughter of the candid cult figure Dr. Ruth, is planning a June wedding to Joel Einleger, a marketing services manager for Pinpoint Marketing Inc. in New York. Miriam, who crewed at Barnard, is now a member of the doctoral candidate crew at Columbia. She's a curriculum developer in the public school project of the College for Human Services.

**Rena Matison Greenblatt**, who sends regards "to the Barnard psychology faculty who helped me get started," has a long memory. She needs one—her PhD in psych at CUNY relied heavily on research on "the effects of brain stem compression on attention and memory." She's doing post-doc work at New York Hospital on a fellowship.

**Margaret**—who used to be a *Darling* but is probably just as nice as a *Yamamoto*—is satisfying her hankering for the past by "assisting in an antiques business in Old Town, Alexandria." Her interests are Chinese porcelain and pottery. What to give the girl who has an MA? "Want a PhD some time," she notes. If you want to send her one, she's in Arlington, VA.

There's been quite a flap over flaps—of the fundraising kind. That's where some people send news of themselves, often written in the kind of handwrit-

ing usually reserved for prescriptions. Don't you folks have typewriters? That's okay—the alumnae office has translated these Rosetta Pebbles for me:

**Laurel Myerson Isicoff** has more than just five and a half years with husband Steven under her belt—she was expecting their second child, too. There won't be much belt-tightening in that household since Laurel is a lawyer with Squire, Sanders and Dempsey.

**Angela M. Fanizza-Orphanos** left home without it. Not that she had any choice—she doesn't have one. "I have no children, no second car, and no American Express card," she writes from Cincinnati, where she's interning at University of Cincinnati Medical Center. "But I'm working on them." She wants a hi from **Barbara Hisler**. "I'm very happy to read about my classmates in alumnae notes," she writes. "Although I have never met **Jami Bernard**, I feel as though we're buddies anyway." I just want you to know, Angela—can I call you Angie?—that praise will not turn my head. Of course, anything you need, just call—a special mention, a Swatch watch.

**Gabrielle Porter** and husband Barry have finished renovating their co-op and now want to sign it over to me. Only kidding! (But aren't we buddies, too?) Gabrielle's at Marine Midland Bank in corporate planning.

**Pamela Karasik** is doing vital work with vital organs at the Heart, Lung and Blood Institute at the National Institutes of Health in Bethesda, "looking forward to doing research next year."

**Beth Simon Motschwiller** is a CPA in the financial reporting department of RCA Corp. At press time, she had no light to shed on the GE merger deal.

**C. Denise Yarbrough Turner** has a candidate for the class of 2007, named Bonnie Lynne. She also has a new job at Szold and Brandwen on Wall Street—reasonable hours, sane people.

**Ida Markewich Lawrence** is reported by some Class of '78 spy to have moved to Princeton with husband Geoff.

I've been doing some travel writing for *The Post*—France, Austria, Switzerland, Italy. . . Oh, it's so exhausting traveling to swank places for free. I'm sure you can sympathize.

79

**Marianne Goldstein**  
601 West 115th St., Apt. 33A  
New York, NY 10025

We have two weddings to announce in this issue of *Barnard Alumnae*. **Donna Masters** added **de Pacheco** to her name when she married Luis, CC'79 and an MD, in July 1984. Donna and Luis live in Boston.

From *The New York Times* we learned that **Laurie Ruckel** married David Ulrich on February 1 of this year. A graduate of Boston U School of Law, Laurie works for the New York law firm of Hess Segall Guterman Pelz Steiner & Barovick. Her husband is president of the Royal Glass Corp. of Englewood, NJ.

From Randolph, MA, **Elinor Louis** wrote: "I am completing my doctorate in clinical psychology and working as a psychologist in a community mental health center. My husband of two years, Mark Itzkowitz (CC'79), is an attorney in Boston."

**Beth Brainard** is a program administrator for the United States Tennis Association Center for Education and Recreational Tennis.

After doing legislative work in Washington, DC for three years, **Chai Feldblum** went to Harvard Law School and graduated in 1985. She is clerking for Judge Frank Coffin of the US Court of Appeals for the First Circuit.

**Devora Steinmetz** finished her doctorate at Columbia in comparative medieval literature in October 1984 and gave birth to Akiva Bezalel Steinmetz-Silber in July 1985.

Two other classmates wrote in with newborn news: **Daria Vanides Voorhees** is the mother of Samantha, and **Jodie Rood Garfinkel** had a baby girl, Ariel, on October 22, 1985.

80

**Christina E. Steck**  
201 East 36th Street, Apt. 6E  
New York, NY 10016

**Amber Spence Zeidler** writes from California that she gave birth to her second child, another girl, Giamaica Day. Amber had been teaching English in an inner-city high school until the birth of her daughter. She and her husband, Paul, bought "a little blue cottage" in an L.A. suburb. Amber adds: "I regret missing our 5-year Reunion. . . but wild horses won't keep me from the 10th, when I plan to be a figure of glamour or at least have a figure again."

And, there's lots more in this space for babies. . . **Diane Bennett Eidman** gave birth to a baby boy a couple of months ago. . . **Joyce Gabel Straus** is the proud mother of a year-old daughter. . . and **Naomi Schacter Schuchalter**, who is living in Israel, recently visited New York City with her 18-month-old son, Danny.

**Beth Gross** writes that she married Ronny Herskovits in 1984, and that she now has "a beautiful little girl, Pnina," who is almost a year old. Beth graduated from Einstein Medical School and is a radiology resident at Montefiore Hospital.

In the last column I mentioned that **Debbie Lerner** had married and had become an attorney in D.C. What I didn't mention was that Debbie's husband is Beth's older brother, Joel Gross, who is also an attorney.

**Rachelle Klapper Meth** has taken a year leave of absence from her pediatrics residency program following the September birth of her son, Ephraim.

In non-baby related news, **Teri Sivilli** started a new job last December. She is now an editor of marketing publications at Dean Witter.

**Mary F. O'Connor** married William Spinner last year. They are living in Hershey, PA.

81

**Chendy Kornreich**  
200 Winston Drive, #2319  
Cliffside Park, NJ 07010

"1985 was a year of changes for me," **Carol Eliassen** wrote in a recent note. She graduated from Mount Sinai Medical School in May and entered an ob/gyn residency program. "Early on I discovered that ob/gyn was not for me," she told us, "and I decided to switch fields." She was happy to report she'd been accepted into the pathology residency program at NYU, starting this July.

**Lisa Lenz** received her MA in elementary education from Teachers College and was planning to do further work with gifted students.

A resident of the West Village, **Nicole Bokat** is teaching freshman English at NYU while she works on her PhD in American/English lit.

**Suzanne Moore** and Jeff Martin were married in Manhattan on February 16. Suzanne is a vice president of Quinn, Brein & Block, a public relations firm, and her husband is a comedy writer for "Late Night With David Letterman."

The Wilkes-Barre (PA) *Times Leader* announced that **Erin Kelley** joined their staff as a copy editor. She worked as an associate editor at Macmillan before joining the paper in November.

Do you realize it's been five years since we graduated? I hope you're planning to join your classmates at Reunion, May 16 and 17. See you there!

82

**Nancy Tuttle**  
202 Riverside Dr., Apt. 4D  
New York, NY 10025

**Laura Ammann** sends "My best regards to Barnard and NYC!!" from her west coast home of one year—San Francisco. She is a news editor and writer for KCBS, the local CBS News radio station, and adds, "I enjoy getting my stories 'on the air!'"

Another writing classmate is **Beverly Esielonis**, who has been appointed technical writer in the marketing department of Schleicher & Schuell, a

manufacturer of filtration systems. She lives in South Hamilton, MA.

From the *Boston Jewish Advocate*, we learned that **Deborah Margolis** is director of the Solomon Schechter Day School of Merrimack Valley, in Haverhill, MA. She has an EdM in psychology from Harvard and studied at Hebrew U in Jerusalem.

**Isabel Nieves Salamon**'s upbeat note reads, "I have been happily married to Ricardo Salamon (CC'81) for over two years and I am proud to announce that I am expecting a child in July. It should be a great year."

In November of last year, **Lisa Bostrom** married Kevin Williams; they call Orange, CA "home."

As part of a celebration of Jewish Theological Seminary's 100th anniversary, **Elana Kanter**, a rabbinical student at JTS, was the special guest of Congregation Tifereth Israel in Columbus, OH in November.

83

**Michele Menzies**  
47 George Street  
Tenafly, NJ 07670

After receiving a master's in English from UVA last May, **Mira Mincis** moved west and began teaching at the Alexander Dawson School, a private boarding school near her home in Lafayette, CO. There she teaches ninth and eleventh grades and is a house parent. "The Rockies are awesome!" she wrote, adding that she loves skiing and snowshoeing. Last we heard, she was hoping to be in Spain this summer.

**Maggie Levenstein** is in her second year in a PhD program in economics at Yale, and wrote that "David [no last name!] and I are engaged."

On the subject of knot-tying, we have two weddings to report. In June 1985, **Jamie Dweck** married Michael Katz, CC'83 and CU Bus. '85. They live on Manhattan's West Side. **Linda McNally** and Robert Burke were married in October 1985; their home is in Brooklyn.

Back at Barnard, **Kathleen Morrisette**, an account representative at CIGNA, took part in a Career Services workshop on finance, insurance and banking in January.

84

**Alison Hanna**  
123 Nevins Street, Apt. 3  
Brooklyn, NY 11217

**Emily Novick** is a first-year student at NYU Law School, where she's in good company—she writes, "I notice there are many other Barnard grads here too!"

A notice in the February 2 *New York Times* told of **Jessica Effenbein**'s engagement to Robert Feinstein. Jessica is a special assistant to Baltimore Mayor William Schaefer; her fiance is a Columbia College graduate and a student in European history at Johns Hopkins.

The same paper one week later announced that **Jody Abramowitz** and Andrew Weisman are planning to marry on May 3. Jody, who has a master's in public administration, is a budget analyst for New York City's Office of Management and Budget. Andrew graduated from Columbia College and is a financial consultant with Shearson Lehman Bros.

For a year and a half, **Elizabeth Klebanoff** has been working at the Federal Reserve Bank of New York in the foreign exchange department, a job she finds "very interesting." Although she enjoys living in NYC, she says, "I certainly miss the freedom of my Barnard days."

**Jackie Strauss**'s mother, **Rochelle Siegman Strauss** '57, wrote in to say that Jackie is also living in New York, and working for Merrill Lynch.

85

**Maris Fink**  
6 Todd Lane  
Stamford, CT 06905

On behalf of the Barnard Fund Alumnae Committee I am calling to your attention a very special membership society.

The President's Circle was founded by people who share an appreciation of the education Barnard offers and a determination to make it available to today's students. The Sponsors, Councillors and Associates who sustain the Circle provide unrestricted support annually,

**And that income. . .**

- helps provide scholarship aid to our highly qualified students.
- enables the College to attract and keep teacher-scholars of the caliber we associate with Barnard's tradition of academic excellence, and
- demonstrates to outside funding sources—foundations and corporations—that their support is being matched by Barnard's own.

There are three categories of Circle membership:

**Barnard Sponsors** are those alumnae and other friends whose level of support is \$5,000 or more annually; they are invited to participate in special activities with the President throughout the year.

**Barnard Councillors** are those alumnae and other friends who contribute \$1,000 to \$4,999 each year. Councillors and Sponsors are invited to a gala event in early December.

**Barnard Associates** are those alumnae and other friends whose level of support ranges from \$500 to \$999 annually. All members of the President's Circle—Barnard Sponsors, Councillors, and Associates—are honored during reunion weekend in mid-May.

Please make a special commitment to Barnard College. When you receive the annual appeal letter, consider increasing your unrestricted contribution to the College to qualify for membership in the Circle.



Harriet Inselbuch, Chair  
Barnard Fund Alumnae Committee

---

To: Harriet Inselbuch  
Chair, Barnard Fund Alumnae Committee

Yes, I am interested in learning more about the College's special support group, the President's Circle. Please send more information.

---

Name

---

Address

---

Daytime Telephone

Please mail to: President's Office, Barnard College, 3009 Broadway, New York, NY 10027-6598

Did you know that you can make a gift to Barnard College in the form of—

- Cash
- Appreciated Securities
- Real Estate
- Closely-held Stock
- Tangible Assets
- Life Insurance

and that you can make a gift to Barnard which will—

- Pay you (and another beneficiary) income for life
- Possibly increase your spendable income
- Reduce or eliminate capital gains taxes on donated assets
- Save income taxes
- Avoid the burden of managing some of your assets.

If you would like information about the ways you can give to Barnard College to help provide quality education for women attending Barnard—now and in the future—please fill out and return the coupon below.

I would like to receive information about

- Gifts of securities, free from capital gains tax
- Gift of a home or farm—retaining life residency
- Gift of Life Insurance
- Gifts that return income to me (and another beneficiary, if desired) for life—(minimum gift, \$5000)
- Other (please specify)

Name: \_\_\_\_\_ Year: \_\_\_\_\_

Address: \_\_\_\_\_

Telephone Daytime: \_\_\_\_\_ Evening: \_\_\_\_\_

Please mail to: Development Office, 115 Milbank Hall, Barnard College, 3009 Broadway, New York, NY 10027-6598.

